



---

---

---

---

---

---

---

## BRONZE PEDESTAL PUMPS TECHNICAL MANUAL



Jabsco



ITT Industries

---

---

---

---

**INDEX**

<b>Page 1</b> .....	Pump Range Option Guide	<b>Page 14</b> .....	Parts & Service	52080
<b>Pages 2:3:4</b> .....	Pump Model Guide	<b>Page 15</b> .....	Parts & Service	52200
<b>Pages 5:6:7:8</b> .....	Performance Curves/Tables	<b>Page 16</b> .....	Parts & Service	10550: 9710
<b>Page 9</b> .....	Parts & Service AL1/4: 6540	<b>Page 17</b> .....	Parts & Service	52220:52270
<b>Page 10</b> .....	Parts & Service 4900: JD3/4	<b>Page 18</b> .....	Parts & Service	9440
<b>Page 11</b> .....	Parts & Service 52010	<b>Page 19</b> .....	Parts & Service	29860-2201
<b>Page 12</b> .....	Parts & Service 52020	<b>Page 20</b> .....	Parts & Service	2620
<b>Page 13</b> .....	Parts & Service 52040	<b>Page 21</b> .....	Parts & Service	6490
		<b>Back Page</b> .....	Operating & Safety Instructions	

**FEATURES**

- \* **Constructed from marine quality bronze and stainless steel for ruggedness and reliability.**
- \* **Self-Prime from dry up to 5m.**
- \* **Easy to service and maintain.**
- \* **Spares available worldwide.**
- \* **Inexpensive to buy and operate**
- \* **Will tolerate abrasive wear.**
- \* **Handles hard and soft solids without clogging.**
- \* **Can pump in either direction.**
- \* **Will not airlock.**

**TYPICAL APPLICATIONS****Industrial**

Circulating and transferring liquids, velocity mixing.  
Pumping coolants on machine tools.  
Pumping waste water from sewers, cellars, yards and sump drainage.  
Chemical Manufacturers and Pharmaceutical Houses-to pump  
Soap, Liquors, Ink, Dyes, Medicines, Alcohol, Various Acids, Tanning  
Liquors, Glycerine, Lotions, Brines etc.  
Water Treatment Chemicals.

**Marine**

Pumping bilge, washdown, Engine Cooling, Circulating water in bait tanks, Dockside pump-out, Deck/Anchor wash.

**Farming**

Pumping water for stock  
Pumping water from wells and cisterns.  
Pumping water from flooded basements.

**Plumbing**

Draining water heaters, laundry tubs.  
Removing sludge, lye water and other caustics from blocked drains and sinks.



## PRODUCT GROUP RANGE/OPTIONS

SIZE	010	020	040	080	200	270	500
Flow @ 1500 rpm	10 L/M	20 L/M	40 L/M	80 L/M	200 L/M	270 L/M	500 L/M
Plain Bearing	AL1/4	6540	4900	JD3/4			
Compact	52010	52020	52040	52080	52200		29860-2201
Composite			10550	9710	52220	52270	
Specialist		2620	6490				

### Options Available (Distributor Fitted)

Std. - Standard All Models

Opt. - Optional All Models

Model No - Option Available For These Models Only

Impellers	010	020	040	080	200	270	500
Std Pressure Neoprene	Std.	Std.	Std.	Std.	Std.	Std.	
Medium Pressure Neoprene							Std.
High Pressure Neoprene			52040/10550	52080/9710	Opt.		
Nitrile	AL1/4	6540	Opt.	Opt.	Opt.	Opt.	

### See curves/tables for performance of impellers

Cams-Full	Std.	Std.	Std.	Std.	Std.	Std.	Std.
1/2	Opt.	6540/2620	Opt.	Opt.	Opt.		
2/3				Opt.			

#### Note

1/2 Cam Reduces Flow by Approximately 50%

2/3 Cam Reduces Flow by Approximately 25%

#### Note

All Performance Data shown in this publication can vary by plus or minus 15%

### PLAIN BEARING



### DESIGN FEATURES

#### MODEL AL 1/4-200

<b>Body</b>	Bronze
<b>Impeller</b>	Jabsco Neoprene Compound
<b>Shaft</b>	Stainless Steel Type 431 S29 to BS970
<b>Shaft Seal</b>	Packing Type
<b>Bearings</b>	Plain
<b>Ports</b>	1/4" BSP to BS21 (DIN2999)
<b>Weight</b>	0.75 kg



#### MODEL 6540-200

<b>Body</b>	Bronze
<b>Impeller</b>	Jabsco Neoprene Compound
<b>Shaft</b>	Stainless Steel Type 431 S29 to BS970
<b>Shaft Seal</b>	Packing Type
<b>Bearings</b>	Plain
<b>Ports</b>	3/8" BSP to BS21 (DIN2999)
<b>Weight</b>	1 kg



#### MODEL 4900-200

<b>Body</b>	Bronze
<b>Impeller</b>	Jabsco Neoprene Compound
<b>Shaft</b>	Stainless Steel Type 431 S29 to BS970
<b>Shaft Seal</b>	Packing Type
<b>Bearings</b>	Plain
<b>Ports</b>	1/2" BSP to BS21 (DIN2999)
<b>Weight</b>	1.5 kg



#### MODEL JD 3/4-200

<b>Body</b>	Bronze
<b>Impeller</b>	Jabsco Neoprene Compound
<b>Shaft</b>	Stainless Steel Type 431 S29 to BS970
<b>Shaft Seal</b>	Packing Type
<b>Bearings</b>	Plain
<b>Ports</b>	3/4" BSP to BS21 (DIN2999)
<b>Weight</b>	2 kg

### COMPACT SERIES



#### MODEL 52010-2001

<b>Body</b>	Bronze
<b>Impeller</b>	Jabsco Neoprene Compound
<b>Shaft</b>	Stainless Steel Type 316 S31 to BS970
<b>Shaft Seal</b>	Lip Type
<b>Wearplate</b>	Replaceable
<b>Bearings</b>	Ball
<b>Ports</b>	3/8" BSP to BS21 (DIN2999)
<b>Weight</b>	0.7 kg

### COMPACT SERIES



### DESIGN FEATURES

#### MODEL 52020-2003

<b>Body</b>	Bronze
<b>Impeller</b>	Jabsco Neoprene Compound
<b>Shaft</b>	Stainless Steel Type 316 S31 to BS970
<b>Shaft Seal</b>	Lip Type
<b>Wearplate</b>	Replaceable
<b>Bearings</b>	Ball
<b>Ports</b>	3/8" BSP to BS21 (DIN2999)
<b>Weight</b>	1.4 kg



#### MODEL 52040-2001

<b>Body</b>	Bronze
<b>Impeller</b>	Jabsco Neoprene Compound
<b>Shaft</b>	Stainless Steel Type 316 S31 to BS970
<b>Shaft Seal</b>	Lip Type
<b>Wearplate</b>	Replaceable
<b>Bearings</b>	Ball
<b>Ports</b>	3/4" BSP to BS21 (DIN2999)
<b>Weight</b>	1.5 kg



#### MODEL 52080-2001

<b>Body</b>	Bronze
<b>Impeller</b>	Jabsco Neoprene Compound
<b>Shaft</b>	Stainless Steel Type 316 S31 to BS970
<b>Shaft Seal</b>	Lip Type
<b>Wearplate</b>	Replaceable
<b>Bearings</b>	Ball
<b>Ports</b>	1" BSP to BS21 (DIN2999)
<b>Weight</b>	2.1 kg



#### MODEL 52200-2011

<b>Body</b>	Bronze
<b>Impeller</b>	Jabsco Neoprene Compound
<b>Shaft</b>	Stainless Steel Type 316 S31 to BS970
<b>Shaft Seal</b>	Mechanical, Carbon-Ceramic
<b>Wearplate</b>	Replaceable
<b>Bearings</b>	Ball
<b>Ports</b>	1-1/2" BSP to BS21 (DIN2999)
<b>Weight</b>	5 kg

### COMPOSITE PUMPS



#### MODEL 10550-200

<b>Body</b>	Bronze
<b>Impeller</b>	Jabsco Neoprene Compound
<b>Shaft</b>	Stainless Steel Type 431 S29 to BS970
<b>Shaft Seal</b>	Mechanical, Carbon-Ceramic
<b>Wearplate</b>	Replaceable
<b>Bearings</b>	Ball
<b>Ports</b>	3/4" BSP to BS21 (DIN2999)
<b>Weight</b>	3 kg

**COMPOSITE PUMPS**

**DESIGN FEATURES**
**MODEL 9710-200**

<b>Body</b>	Bronze
<b>Impeller</b>	Jabsco Neoprene Compound
<b>Shaft</b>	Stainless Steel Type 431 S29 to BS970
<b>Shaft Seal</b>	Mechanical, Carbon-Ceramic
<b>Wearplate</b>	Replaceable
<b>Bearings</b>	Ball
<b>Ports</b>	1" BSP to BS21 (DIN2999)
<b>Weight</b>	3.4 kg

**MODEL 52220-0011**

<b>Body</b>	Bronze
<b>Impeller</b>	Jabsco Neoprene Compound
<b>Shaft</b>	Stainless Steel Type 316 S31 to BS970
<b>Shaft Seal</b>	Mechanical, Carbon-Ceramic
<b>Wearplate</b>	Replaceable
<b>Bearings</b>	Ball
<b>Ports</b>	1 1/2" Flanged
<b>Weight</b>	7 kg

**MODEL 52270-2011/-0011**

<b>Body</b>	Bronze
<b>Impeller</b>	Jabsco Neoprene Compound
<b>Shaft</b>	Stainless Steel Type 316 S31 to BS970
<b>Shaft Seal</b>	Mechanical, Carbon-Ceramic
<b>Wearplate</b>	Replaceable
<b>Bearings</b>	Ball
<b>Ports</b>	2" BSP to BS21 (DIN2999) or Flanged 2"
<b>Weight</b>	9 kg

**COMPACT SIZE**

**MODEL 29860-2201**

<b>Body</b>	Bronze
<b>Endcover</b>	Stainless Steel
<b>Impeller</b>	Jabsco Neoprene Compound
<b>Shaft</b>	Stainless Steel 316 S31
<b>Shaft Seal</b>	Mechanical, Carbon-Ceramic
<b>Wearplate</b>	Stainless Steel – replaceable
<b>Bearings</b>	Ball
<b>Ports</b>	Flanged and 2 1/2" BSP internal to BS21 (DIN 2999)
<b>Weight</b>	12.5 kg
<b>Other:</b>	Suitable for accepting Electromagnetic Clutch

### Performance of the Range at 1500 RPM with water (20°C)

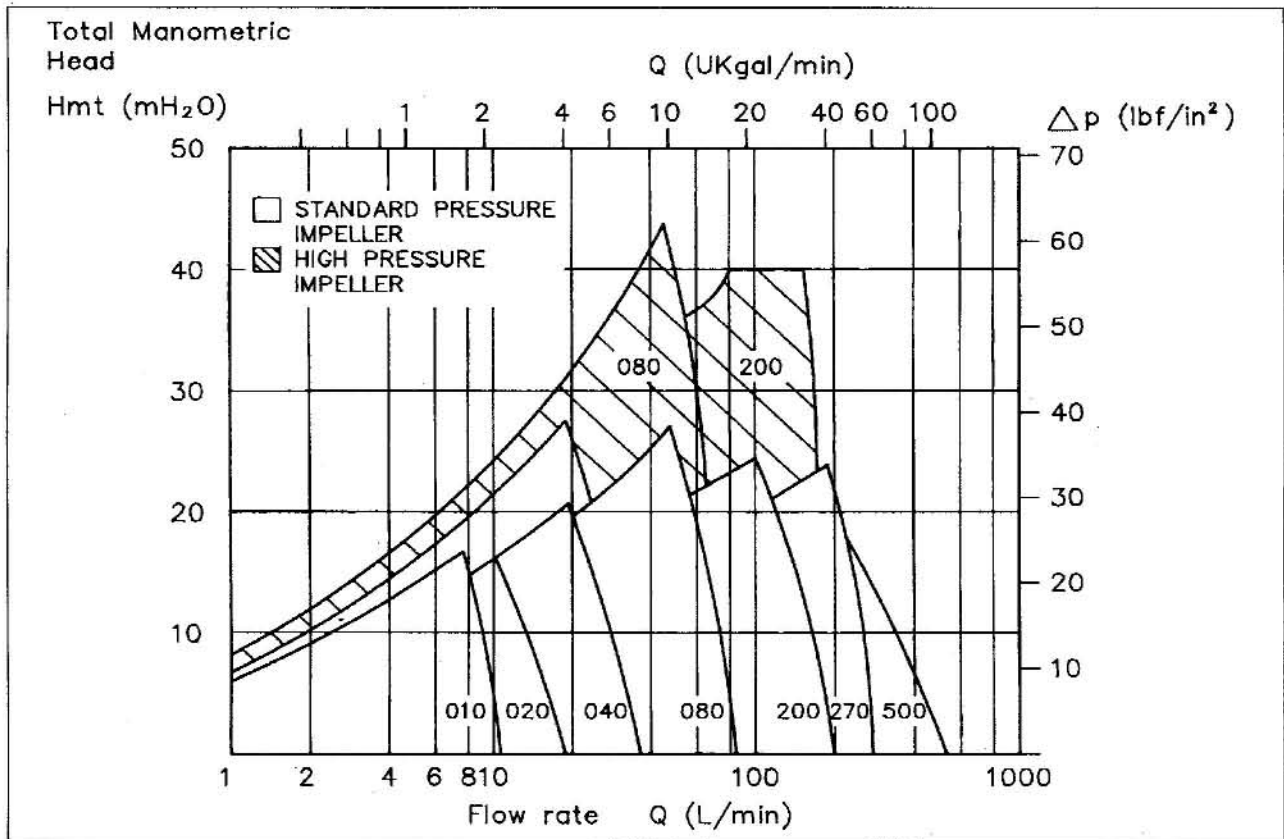

### SIZE 010

Performance Note: Power (watts) figures shown are minimum recommended at pumpshaft

total manometric head	500 rpm 60 watt	1000 rpm 120 watt	1500 rpm 120 watt	2000 rpm 250 watt	2500 rpm 370 watt
m/H <sub>2</sub> O	L/m	L/m	L/m	L/m	L/m
3	3.5	7	10.5	14	17.5
6	2	6.5	10	13.5	17
9	2	5	8.5	12	15.5
12	-	3.5	7	10	13
15	-	-	-	7.5	10.5
*Suction Bore	8 mm	8 mm	8 mm	10 mm	10 mm
Temp °C	Metres	Metres	Metres	Metres	Metres
20	5.5	4.3	3.5	3	1.3
30	5.3	4.1	3.3	2.8	1.1
40	4.9	3.7	2.9	2.4	0.7
50	4.3	3.1	2.3	1.8	0.1

Maximum recommended suction head in mH<sub>2</sub>O at water temperature 20°C.

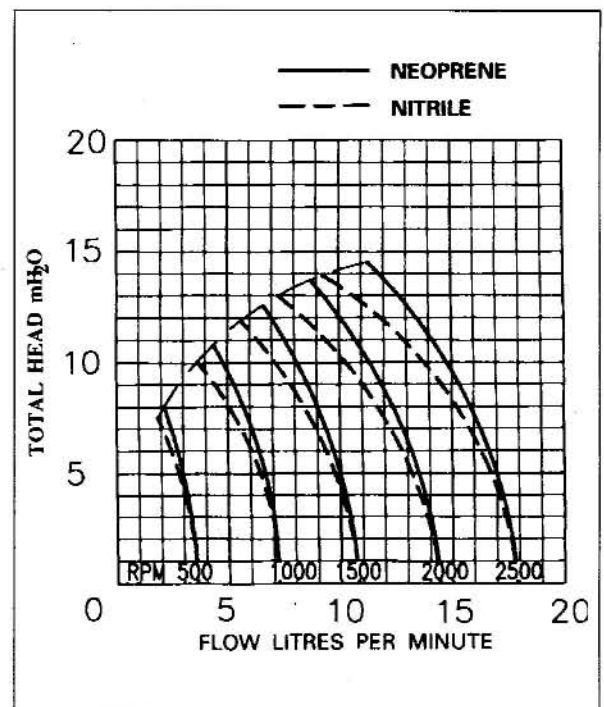

Pump Selection Table and Graph show approximate performance for new pumps with neoprene impeller pumping water (specific gravity 1.00) at 20°C, but note that performance can be affected if water temperature and suction head are higher than shown in above table. If in doubt consult your local Jabsco distributor or factory for application assistance.

\*Minimum nominal recommended bore. Note: Suction Head = Vertical Suction Height + Pipe Losses.

## SIZE 020

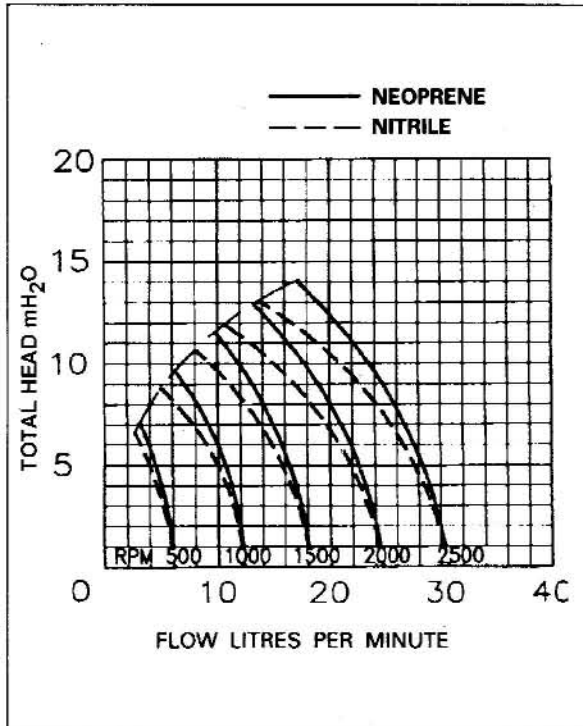

Performance Note: Power (watts) figures shown are minimum recommended at pumpshaft

total manometric head	500 rpm	750 rpm	1000 rpm	1500 rpm	2000 rpm	2500 rpm
	60 watt	90 watt	120 watt	180 watt	250 watt	370 watt
m/H <sub>2</sub> O	L/m	L/m	L/m	L/m	L/m	L/m
3	5.5	8.5	11.5	18	24	30
6	4	7	10	16	22	28
9	-	4	7	13	19	25
12	-	-	-	9	15	21
15	-	-	-	-	9	15
*Suction Bore	10mm	10mm	10mm	10mm	10mm	13mm
Temp °C	Metres	Metres	Metres	Metres	Metres	Metres
20	6	5.2	4.8	4.1	3.2	3.1
30	5.8	5	4.6	3.9	3	2.9
40	5.4	4.6	4.2	3.5	2.6	2.5
50	4.8	4	3.6	2.9	2	1.9

Maximum recommended suction head in mH<sub>2</sub>O at water temperature 20°C

## SIZE 040

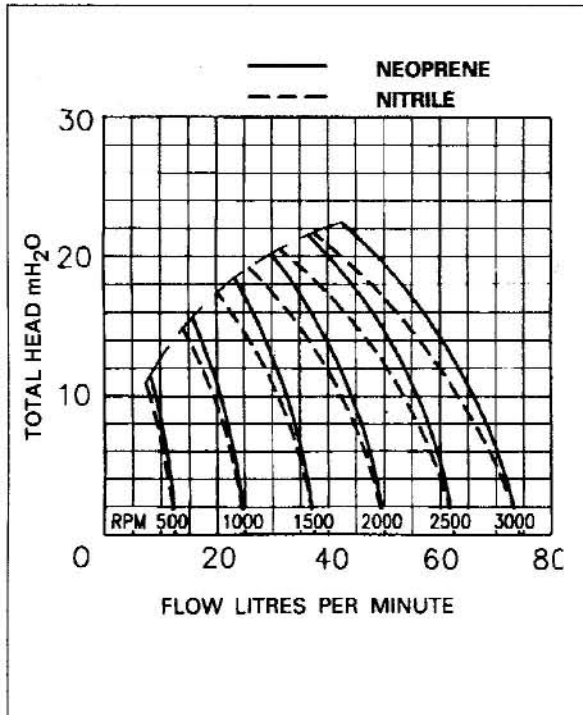

Performance Note: Power (watts) figures shown are minimum recommended at pumpshaft

total manometric head	500 rpm	1000 rpm	1500 rpm	2000 rpm	2500 rpm	3000 rpm
	120 watt	250 watt	370 watt	550 watt	550 watt	3750 watt
m/H <sub>2</sub> O	L/m	L/m	L/m	L/m	L/m	L/m
3	12	24.5	36.5	49	61.5	73.5
5	11.5	23.5	35.5	47.5	60.5	72
9	10	22	33.5	45.5	57	69
12	8.5	19.5	31	42.5	53.5	64.5
15	-	16	27.5	38	49	59.5
18	-	13.5	23	33.3	43	53
21	-	-	-	27	36.5	45.5
24	-	-	-	-	-	36.5
*Suction Bore	20mm	20mm	20mm	20mm	25mm	25mm
Temp °C	Metres	Metres	Metres	Metres	Metres	Metres
20	7.6	7	5.6	3.6	2.3	0.8
30	7.4	6.8	5.4	3.4	2.1	0.6
40	7	6.4	5	3	1.7	Positive Head Required
50	6.4	5.8	4.4	2.4	1.1	

Maximum recommended suction head in mH<sub>2</sub>O at water temperature 20°C

Pump Selection Tables and Graphs show approximate performance for new pumps with neoprene impeller pumping water (specific gravity 1.00) at 20°C, but note that performance can be affected if water temperature and suction head are higher than shown in above tables. If in doubt consult your local Jabsco distributor or factory for application assistance.

\*Minimum nominal recommended bore. Note: SUCTION HEAD = VERTICAL HEIGHT + PIPE LOSSES.



## SIZE 080

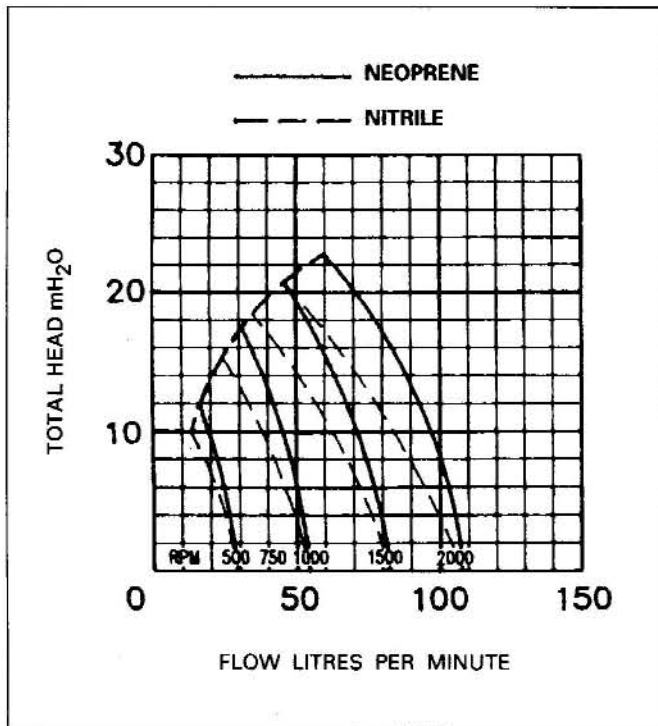

Performance Note: Power (watts) figures shown are minimum recommended at pumpshaft

total manometric head	500 rpm	750 rpm	1000 rpm	1500 rpm	2000 rpm
	180 watt	180 watt	250 watt	550 watt	750 watt
m/H <sub>2</sub> O	L/m	L/m	L/m	L/m	L/m
3	26.5	40	53	80	107
5	24.5	37.5	57	78	104
9	21	34.5	47.5	74	100
12	16.5	29	42.5	68	94
15	-	23	36	61	86
18	-	-	29	52.5	77
21	-	-	-	42	66
*Suction Bore	25mm	25mm	25mm	25mm	32mm
Temp°C	Metres	Metres	Metres	Metres	Metres
20	7.2	6.9	6.2	4.1	2.2
30	7	6.7	6	3.9	2
40	6.6	5.3	5.6	3.5	1.6
50	6	5.7	5	2.9	1

Maximum recommended suction head in mH<sub>2</sub>O at water temperature 20°C

## SIZE 200

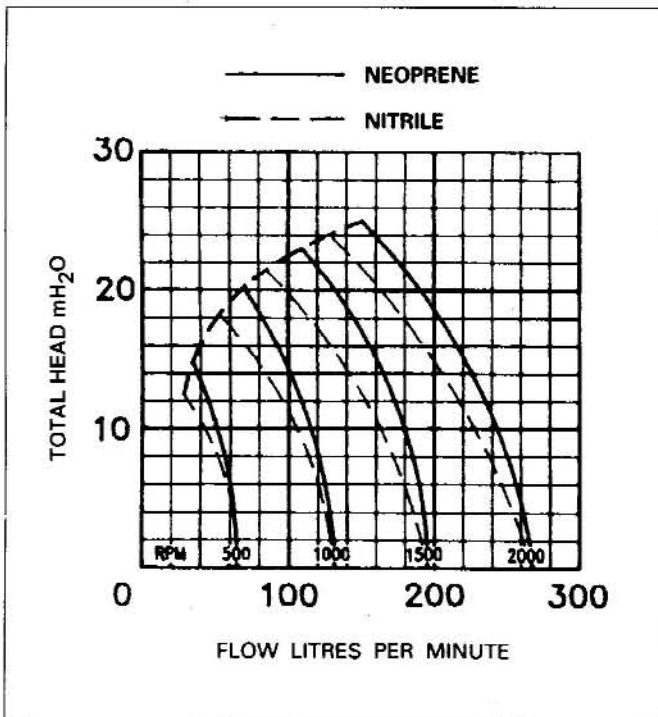

Performance Note: Power (watts) figures shown are minimum recommended at pumpshaft

total manometric head	500 rpm	1000 rpm	1500 rpm	2000 rpm
	180 watt	750 watt	1100 watt	1800 watt
m/H <sub>2</sub> O	L/M	L/m	L/m	L/m
3	64.5	130	195	261
5	60.5	126	191	256
9	54	118.5	183.5	248
12	45	109	173	236.5
15	33.5	96.5	159	222
18	-	81	142.5	204
21	-	63	123	183
24	-	-	100	159
*Suction Bore	40mm	40mm	40mm	40mm
Temp°C	Metres	Metres	Metres	Metres
20	7	5.8	3.6	1
30	6.8	5.6	3.4	0.9
40	6.4	5.2	3	0.5
50	5.8	4.6	2.4	-

Maximum recommended suction head in mH<sub>2</sub>O at water temperature 20°C

Pump Selection Tables and Graphs show approximate performance for new pumps with neoprene impeller pumping water (specific gravity 1.00) at 20°C, but note that performance can be affected if water temperature and suction head are higher than shown in above tables. If in doubt consult your local Jabsco distributor or factory for application assistance.

\*Minimum nominal recommended bore. Note: SUCTION HEAD = VERTICAL HEIGHT + PIPE LOSSES.

## SIZE 270

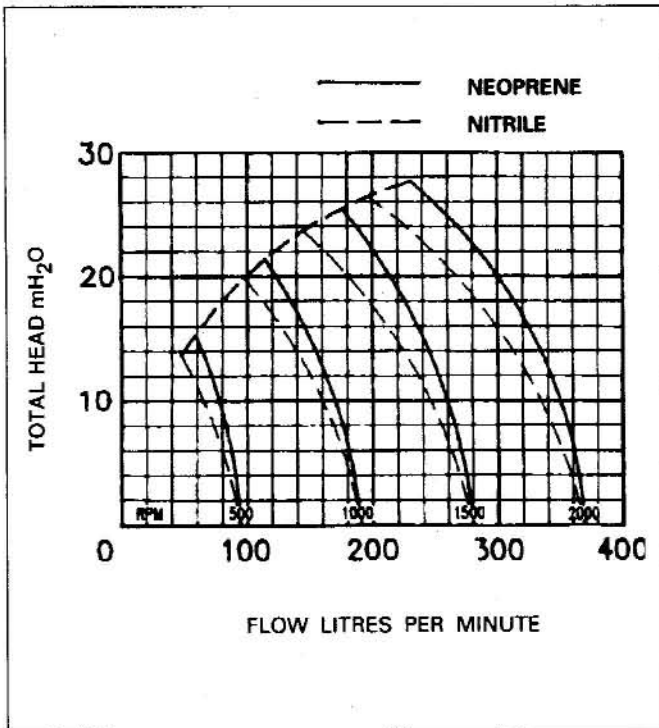

**Performance Note:** Power (watts) figures shown are minimum recommended at pumpshaft

total manometric head	500 rpm	1000 rpm	1500 rpm	2000 rpm
	550 watt	1500 watt	1800 watt	3000 watt
m/H <sub>2</sub> O	L/m	L/m	L/m	L/m
3	91	183	275	368
5	87	179	271	363
9	81	172	263	355
12	72	162	253	343
15	60	150	239	329
18	-	134	223	311
21	-	116	203	290
24	-	-	180	265
24	-	-	-	238
*Suction Bore	51 mm	51 mm	51 mm	51 mm
Temp°C	Metres	Metres	Metres	Metres
20	7.4	6.9	4.8	2.3
30	7.2	6.7	4.6	2.1
40	6.8	6.3	4.2	1.7
50	6.2	5.7	3.6	1.1

**Maximum recommended suction head in mH<sub>2</sub>O at water temperature 20°C**

## SIZE 500

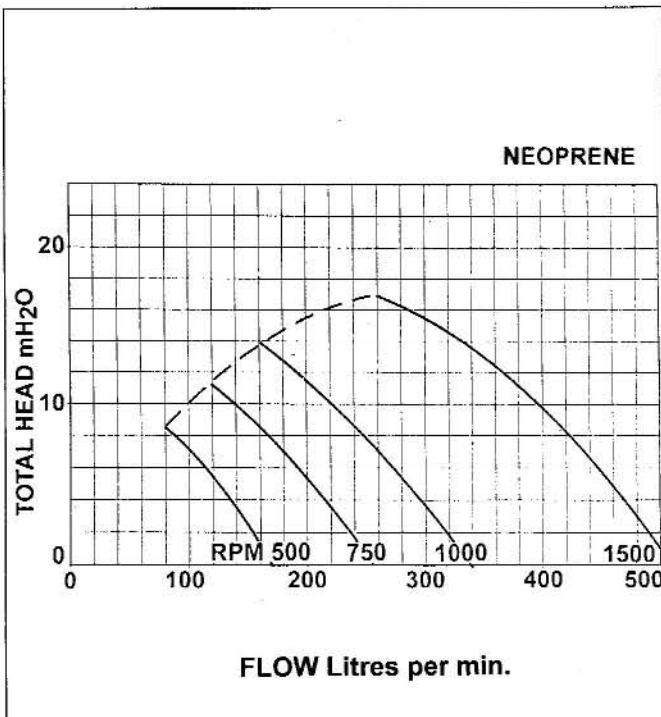

**Performance Note:** Power (watt) figures shown are minimum recommended at pumpshaft.

Total manometric head	500 rpm	750 rpm	1000 rpm	1500 rpm
	1500 watt	2200 watt	2200 watt	4000 watt
5	132	220	303	463
9	79	165	246	402
12	40	127	210	361
15	-	60	145	308
18	-	-	-	250
20	-	-	-	194
Suction Bore	63.5mm	63.5mm	63.5mm	63.5mm
Temp	Metres	Metres	Metres	Metres
20°C	7.5	7.0	6.0	3.5
30°C	7.3	6.8	5.8	3.3
40°C	7.0	6.5	5.5	2.8
50°C	6.5	6.0	5.0	2.3

**Maximum recommended suction head in mH<sub>2</sub>O at water temperature 20°C**

Pump Selection Tables and Graphs show approximate performance for new pumps with neoprene impeller pumping water (specific gravity 1.00) at 20°C, but note that performance can be affected if water temperature and suction head are higher than shown in above tables. If in doubt consult your local Jabsco distributor or factory for application assistance.

\* Minimum nominal recommended bore. Note: **SUCTION HEAD = VERTICAL HEIGHT + PIPE LOSSES.**

### EXPLODED VIEW

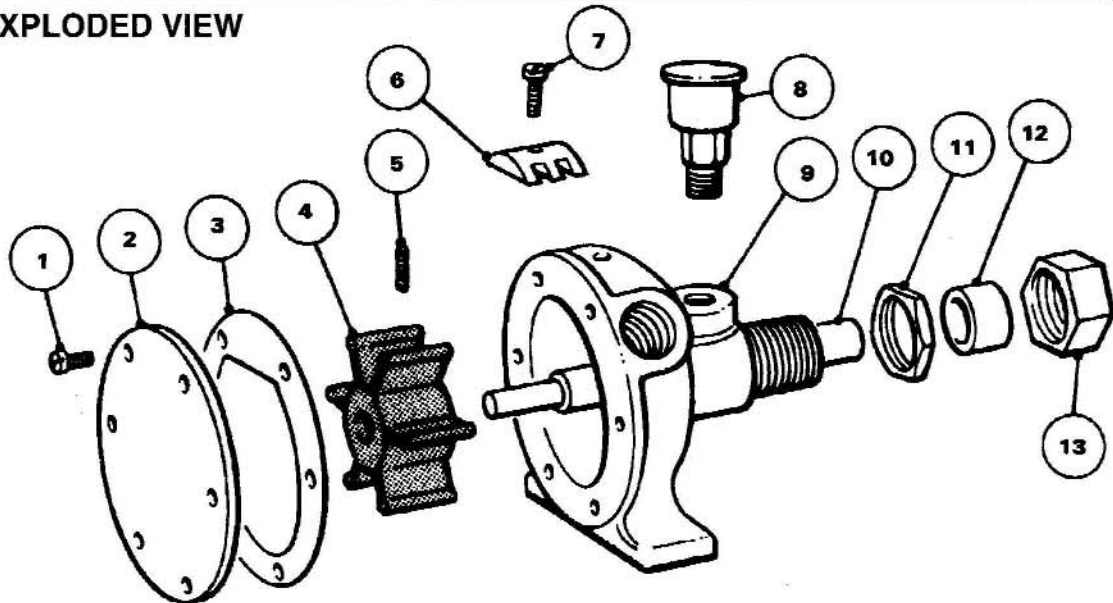

#### PARTS LIST AL1/4-200

Key	Description	Qty	Part No
1	Endcover Screw*	6	SP1002-01
2	Endcover	1	AL6-200
3	Gasket*	1	1126
4	Impeller*	1	4528-0001B
5	Screw-Impeller to Shaft*	1	SP1009-05
6	Cam	1	AL8
7	Cam Screw	1	SP1002-02
8	Grease Cup	1	SP1503-01
9	Body	1	AL4-200
10	Shaft	1	AL10
11	Lock Nut	1	AL18
12	Packing*	1	AL22
13	Pack Nut	1	AL16

#### PARTS LIST 6540-200

Key	Description	Qty	Part No
1	Endcover Screw*	6	SP1002-01
2	Endcover	1	3992
3	Gasket*	1	2995-0030
4	Impeller*	1	673-0001B
5	Screw-Impeller to Shaft*	1	SP1010-06
6	Cam	1	2907-0001
7	Cam Screw	1	SP1002-02
8	Grease Cup	1	SP1503-01
9	Body	1	6544-200
10	Shaft	1	6547
11	Lock Nut	1	B18
12	Packing*	1	B22
13	Pack Nut	1	B16

#### MODEL AL1/4-200

Service Kit No SK1  
Contains Parts marked \*

#### Options:-

Nitrile Impeller Part No 4528-0003B  
1/2 Cam Part No AL8-01  
1/2 Cam Screw Part No SP1002-04

#### MODEL 6540-200

Service Kit No SK205  
Contains Parts marked \*

#### Options:-

Nitrile Impeller Part No 673-0003B  
1/2 Cam Part No 2441  
1/2 Cam Screw Part No SP1002-09

### SERVICE INSTRUCTIONS

**Dis-Assembly** Inspect all parts for wear or damage and replace if necessary

1. Remove endcover screws, endcover and gasket.
2. Remove drive coupling or pulley and loosen packing nut and remove.
3. Clean and remove any burrs from the end of the shaft.
4. Remove shaft and impeller assembly from body using water pump pliers.
5. Remove impeller to shaft screw, slide impeller off shaft.
6. Loosen cam screw and remove cam, (clean off any old jointing compound).
7. From pack nut remove old packing using a small screw-driver.

#### Assembly

1. Coat cam screw threads and top of cam with a non setting jointing compound. Install in body.
2. Position impeller onto shaft, locate hole in impeller and then replace screw.
3. Lightly lubricate the impeller bore with a good quality water pump grease. Insert shaft and impeller assembly into pump body with a rotary motion.
4. Dip new packing in a lifting machine oil and install pack nut.
5. Replace gasket, endcover and endcover screws.
6. Replace pack nut onto shaft and "Hand Tighten" locknut. Allow for slight leakage for a short time in order to lubricate the packing until it is run-in. Readjust as necessary.

**CAUTION: OVERTIGHTENING OF THE PACK NUT WILL INCREASE THE TORQUE REQUIREMENT AND MAY BURN THE PACKING OR GROOVE THE SHAFT UNDER THE PACKING.**

#### INSTALLATION DRAWING AL 1/4-200

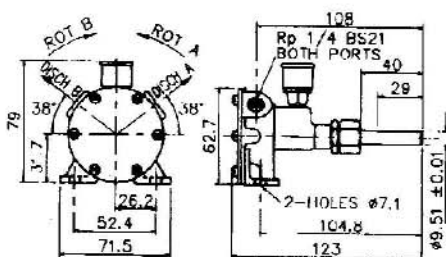

#### INSTALLATION DRAWING 6540-200

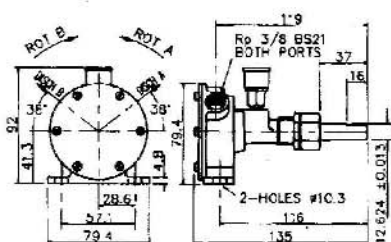

### EXPLODED VIEW

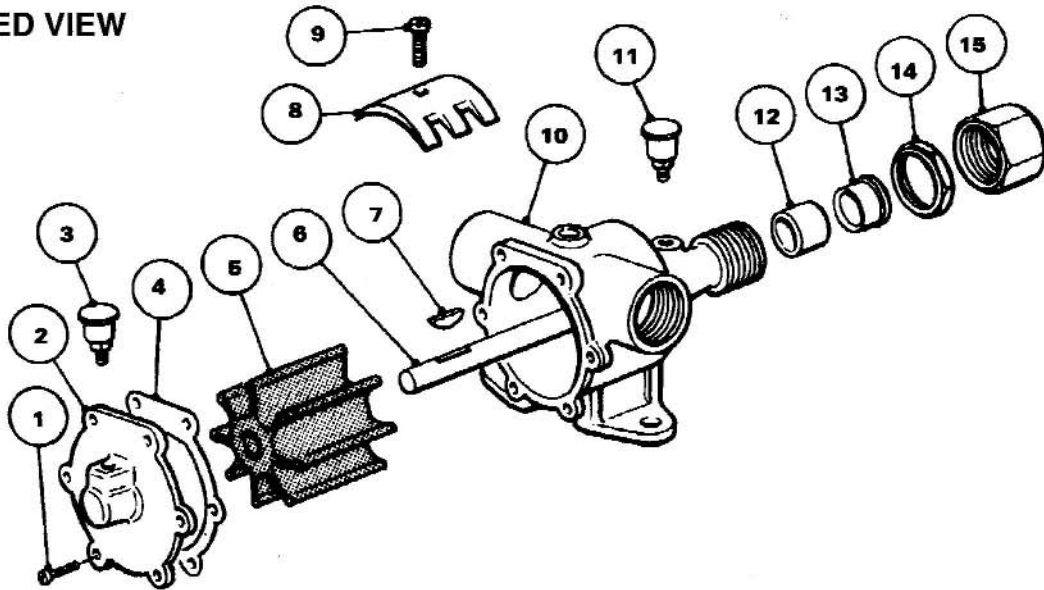

#### PARTS LIST 4900-200

Key	Description	Qty	Part No
1	Endcover Screws*	6	SP1003-09
2	Endcover	1	4905
3	Grease Cup	1	SP1503-01
4	Gasket*	1	4908
5	Impeller*	1	4568-0001B
6	Shaft	1	C10-01
7	Key	1	SP1402-01
8	Cam	1	490
9	Cam Screw	1	SP1003-07
10	Body	1	4904-200
11	Grease Cup	1	SP1503-01
12	Packing*	1	3791
13	Packing Gland	1	C20
14	Lock Nut	1	C18
15	Pack Nut	1	C16

#### PARTS LIST JD3/4-200

Key	Description	Qty	Part No
1	Endcover Screws*	6	SP1003-02
2	Endcover	1	D6-01-200
3	Grease Cup	1	SP1503-01
4	Gasket*	1	706-01
5	Impeller*	1	4598-0001B
6	Shaft	1	D10-01
7	Key	1	SP1402-01
8	Cam	1	934
9	Cam Screw	1	SP1004-01
10	Body	1	JD4-200
11	Grease Cup	1	SP1503-01
12	Packing*	1	3791
13	Packing Gland	1	C20
14	Lock Nut	1	C18
15	Pack Nut	1	C16

#### MODEL 4900-200

Service Kit No SK234  
Contains Parts marked \*

#### Options:-

Nitrile Impeller Part No 4568-0003B  
1/2 Cam Part No 10336  
1/2 Cam Screw Part No SP1003-09

#### MODEL JD3/4-200

Service Kit No SK220  
Contains Parts marked\*

#### Options:-

Nitrile Impeller Part No 4598-0003B  
1/2 Cam Part No 2431  
1/2 Cam Screw Part No SP1004-10  
2/3 Cam Part No 3255  
2/3 Cam Screw Part No SP1004-10

### SERVICE INSTRUCTIONS

**Dis-Assembly** Inspect all parts for wear or damage and replace if necessary

1. Remove endcover screw, endcover and gasket.
2. Remove drive coupling or pulley and loosen packing nut.
3. Remove shaft and impeller assembly from body.
4. Remove impeller by sliding it off towards flatted end of shaft.
5. Loosen cam screw and remove cam, (clean off any old jointing compound).
6. Remove packing nut and gland.
7. Remove old packing with small screwdriver.

#### Assembly

1. Coat cam screw threads and top of cam with a non setting compound. Install in body.
2. Replace key in shaft and slide impeller onto the shaft from the flatted end.
3. Replace shaft and impeller assembly into body.  
Note: Lubricate impeller bore with a good quality pump grease and shaft with machine oil prior to placing in body.
4. Dip new packing in light machine oil and install packing, gland and nut.
5. Replace gasket, endcover and screw.
6. Replace pack nut onto shaft and "Hand Tighten" lock nut. Allow for slight leakage for a short time in order to lubricate the packing until it is "run-in". Re-adjust as necessary. **CAUTION: OVERTIGHTENING OF THE PACK NUT WILL INCREASE THE TORQUE REQUIREMENT AND MAY BURN THE PACKING OR GROOVE THE SHAFT UNDER THE PACKING.**

#### INSTALLATION DRAWING 4900-200

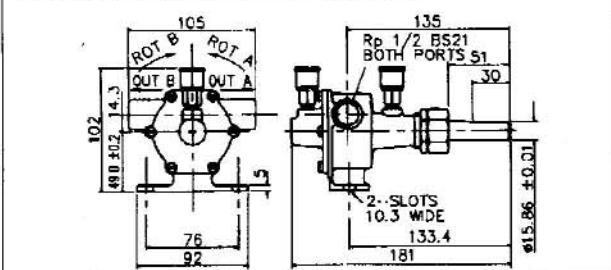

#### INSTALLATION DRAWING JD3/4-200

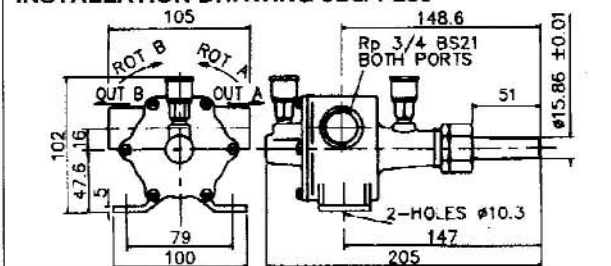

### EXPLODED VIEW

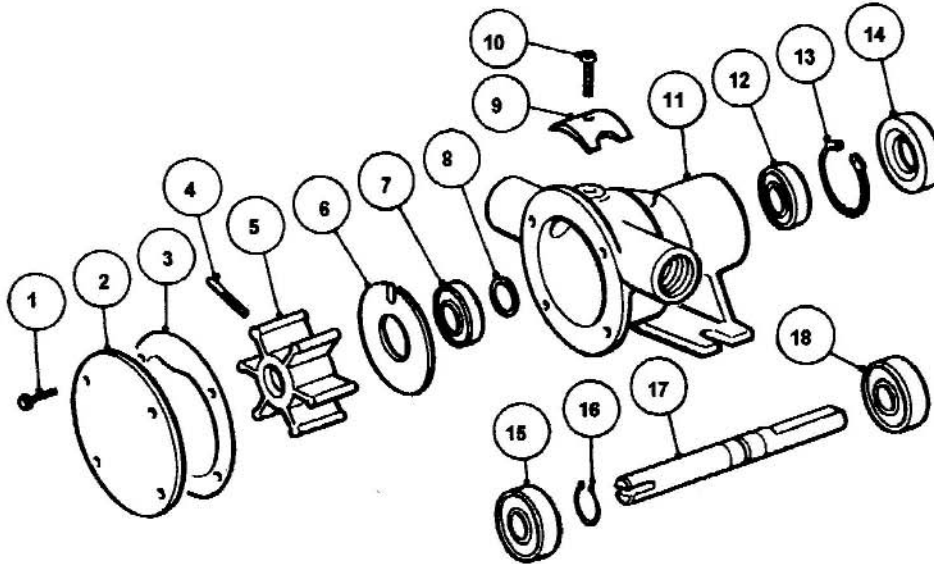

### PARTS LIST MODEL 52010-2001

Key	Description	Qty	Part No
1	Endcover Screw *	6	X3001-095F
2	Endcover	1	29305-0000
3	Gasket*	1	29308-0000
4	Impeller Screw *	1	SP1009-05
5	Impeller *	1	22405-0001B
6	Wearplate	1	29306-0000
7	Seal *	1	SP2701-1006
8	"O" Ring *	1	X4020-210A
9	Cam	1	29303-0000
10	Cam Screw	1	SP1002-09
11	Body	1	52014-2000
12	Bearing Seal	1	SP2701-1006
13	Retaining Ring	1	SP1701-4438
14	Bearing Seal	1	SP2701-0501
15	Bearing	1	SP2601-0457
16	Retaining Ring	1	SP1701-4440
17	Shaft	1	52017-0000
18	Bearing	1	SP2601-0457

Service Kit No SK404-0101 Contains Parts marked \*

### INSTALLATION DRAWING

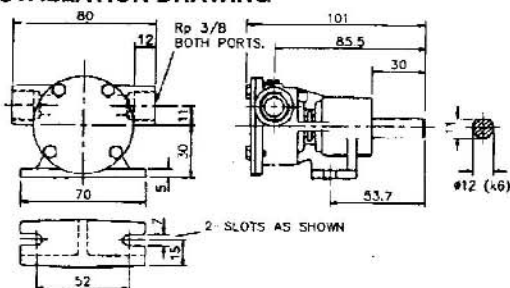

### SERVICE INSTRUCTIONS

**Dis-Assembly** Inspect all parts for wear or damage and replace if necessary

1. Remove endcover screws, endcover and gasket.
2. Remove impeller.
3. Remove wearplate.
4. Loosen cam screw and remove cam, (clean off old jointing compound).
5. Remove seal and 'O' ring with hooked wire.
6. Insert screwdriver between OD of outer bearing seal and pump bore and pry out seal.
7. Remove bearing to body retaining ring.
8. Press on impeller drive end of shaft to remove shaft and bearing assembly. Heating outside of body will ease dis-assembly.
9. Lever bearings apart and remove from shaft. Use extreme care not to mar body bore. Insert screwdriver between OD of inner bearing seal and pump body, and pry out the seal.

### Assembly

1. Lubricate inner bearing seal with grease and press into body bearing seal bore with lip facing away from bearing bore.
2. Push bearings onto shaft and up against retaining ring.
3. Position slinger in body drain area. Insert slotted end of shaft through bearing bore and guide slinger over shaft until bearings contact body.
4. Press on bearing outer race, install bearings into bore. Heating outside of body at bearing area will ease assembly.
5. Install bearing to body retaining ring in body groove.
6. Lubricate outer bearing seal with grease and press into bearing bore until it is flush with the body.
7. Install 'O' ring in groove in seal bore.
8. Lubricate OD and lip seal, then push into place using care not to damage or cut seal lip. (Lip faces impeller bore).
9. Install wearplate in body bore, aligning dimple in wearplate with slot in cam.
10. Coat screw threads, and top of cam with a non setting jointing compound. Install in body.
11. Thread impeller drive screw into impeller.  
Lubricate impeller bore with a light coat of good quality grease and start impeller into bore with a rotary motion until impeller drive screw engages with slot in shaft.
12. Install gasket and endcover and secure with endcover screws.



### EXPLODED VIEW

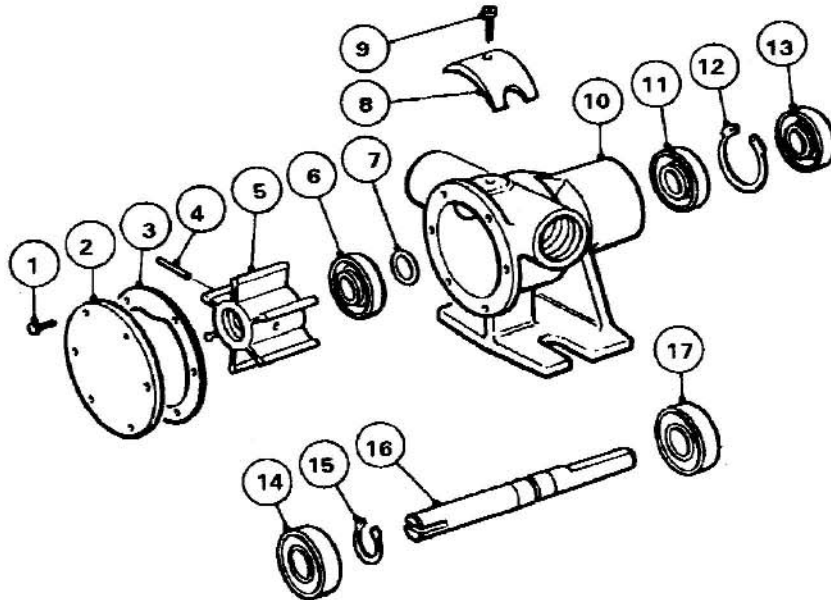

### PARTS LIST MODEL 52020-2001

Key	Description	Qty	Part No
1	Endcover Screw *	6	X3001-095F
2	Endcover	1	3992
3	Gasket *	1	2995-0030
4	Impeller Screw *	1	SP1010-06
5	Impeller *	1	653-0001B
6	Seal *	1	SP2701-1006
7	"O" Ring	1	X4020-210A
8	Cam	1	2907-0001
9	Cam Screw	1	SP1002-09
10	Body	1	52024-2000
11	Bearing Seal	1	SP2701-1006
12	Retaining Ring	1	SP1701-4438
13	Bearing Seal	1	SP2701-0501
14	Bearing	1	SP2601-0457
15	Retaining Ring	1	SP1701-4440
16	Shaft	1	52027-0000
17	Bearing	1	SP2601-0457

Service Kit No SK405-0101 Contains Parts marked\*

### INSTALLATION DRAWING

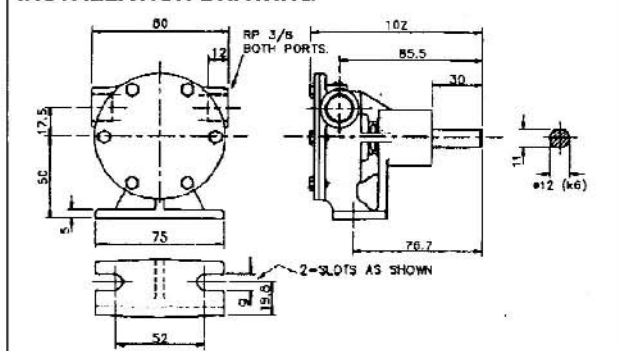

### SERVICE INSTRUCTIONS

**Dis-Assembly** Inspect all parts for wear or damage and replace if necessary

1. Remove endcover screws, endcover and gasket.
2. Remove impeller.
3. Remove wearplate.
4. Loosen cam screw and remove cam, (clean off old jointing compound).
5. Remove seal and 'O' ring with hooked wire.
6. Insert screwdriver between OD of outer bearing seal and pump bore and pry out seal.
7. Remove bearing to body retaining ring.
8. Press on impeller drive end of shaft to remove shaft and bearing assembly. Heating outside of body will ease dis-assembly.
9. Lever bearings apart and remove from shaft. Use extreme care not to mar body bore. Insert screwdriver between OD of inner bearing seal and pump body, and pry out the seal.

### Assembly

1. Lubricate inner bearing seal with grease and press into body bearing seal bore with lip facing away from bearing bore.
2. Push bearings onto shaft and up against retaining ring.
3. Position slinger in body drain area. Insert slotted end of shaft through bearing bore and guide slinger over shaft until bearings contact body.
4. Press on bearing outer race, install bearings into bore. Heating outside of body at bearing area will ease assembly.
5. Install bearing to body retaining ring in body groove.
6. Lubricate outer bearing seal with grease and press into bearing bore until it is flush with the body.
7. Install 'O' ring in groove in seal bore.
8. Lubricate OD and lip seal, then push into place using care not to damage or cut seal lip. (Lip faces impeller bore).
9. Install wearplate in body bore, aligning dimple in wearplate with slot in cam.
10. Coat cam screw threads, and top of cam with a non setting jointing compound. Install in body.
11. Thread impeller drive screw into impeller, and lightly grease impeller bore and start impeller into bore with a rotary motion until impeller drive screw engages with slot in shaft.

### EXPLODED VIEW

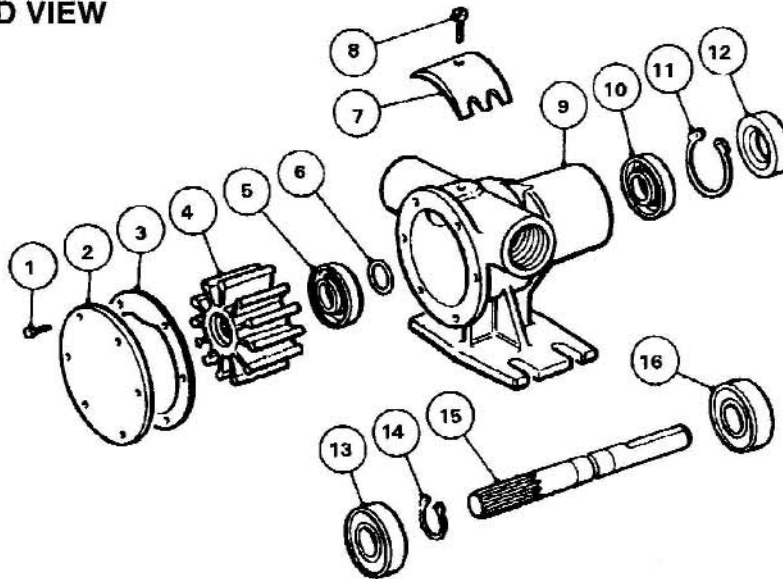

### PARTS LIST MODEL 52040-2001

Key	Description	Qty	Part No
1	Endcover Screw *	6	X3001-095F
2	Endcover	1	3992
3	Gasket *	1	3298
4	Impeller *	1	1210-0001B
5	Seal *	1	SP2700-1027
6	"O" Ring	1	X4020-215A
7	Cam	1	490
8	Cam Screw	1	SP1003-01
9	Body	1	52044-2000
10	Bearing Seal	1	SP2700-1027
11	Retaining Ring	1	SP1701-137
12	Bearing Seal	1	SP2701-1015
13	Bearing	1	SP2601-0451
14	Retaining Ring	1	X3085-017A
15	Shaft	1	52047-0000
16	Bearing	1	SP2601-0451
	Spline Seal	1	4345

Service Kit No SK384-0101 Contains Parts marked\*

### INSTALLATION DRAWING

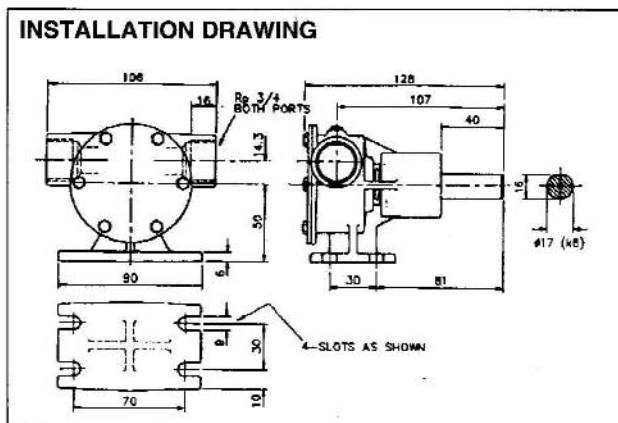

### Options:-

High Pressure Impeller

Part No 3085-0001B

Nitrile Impeller

Part No 1210-0003B

1/2 Cam

Part No 10336

1/2 Cam Screw

Part No SP1003-09

### SERVICE INSTRUCTIONS

**Dis-Assembly** Inspect all parts for wear or damage and replace if necessary

1. Remove endcover screws, endcover and gasket.
2. Remove impeller.
3. Loosen cam screw and remove cam, (clean off old jointing compound).
4. Remove lip seal from body.
5. Insert screwdriver between O.D. of outer bearing seal and pump bore and pry out seal.
6. Remove bearing retaining ring.
7. Press on impeller drive end of shaft to remove shaft and bearing assembly. Heating outside of body will ease dis-assembly.
8. Remove bearing to shaft retaining ring.
9. Supporting bearing inner race, press shaft through bearing.
10. Using extreme care not to mar body bore, insert screwdriver between O.D. of inner bearing seal and pump bore and pry out seal.

### Assembly

1. Lubricate inner bearing seal with grease and press into body bearing seal bore with lip facing away from bearing bore.
2. Support shaft and press bearing onto shaft.
3. Install bearing to shaft retaining ring with flat side towards bearing.
4. Position slinger in body drain area. Insert splined end of shaft through bearing bore and guide slinger over shaft until bearing contacts body.
5. Press on bearing outer face, install bearing into bore.
6. Install bearing to body retaining ring in body groove with flat side towards bearing.
7. Lubricate outer bearing seal with grease and press into bearing bore until it is flush with the body (spring facing outwards).
8. Lubricate O.D. and lip of seal, then push into place, using care not to damage or cut seal lip, (lip faces impeller bore).
9. Coat cam screw threads, and top of cam with a non setting jointing compound and install in body with the cam screw.
10. Lightly grease impeller bore and start impeller into bore with a rotary motion until splines engage, then push into bore.
11. Install gasket and endcover, and secure with endcover screws.

### EXPLODED VIEW

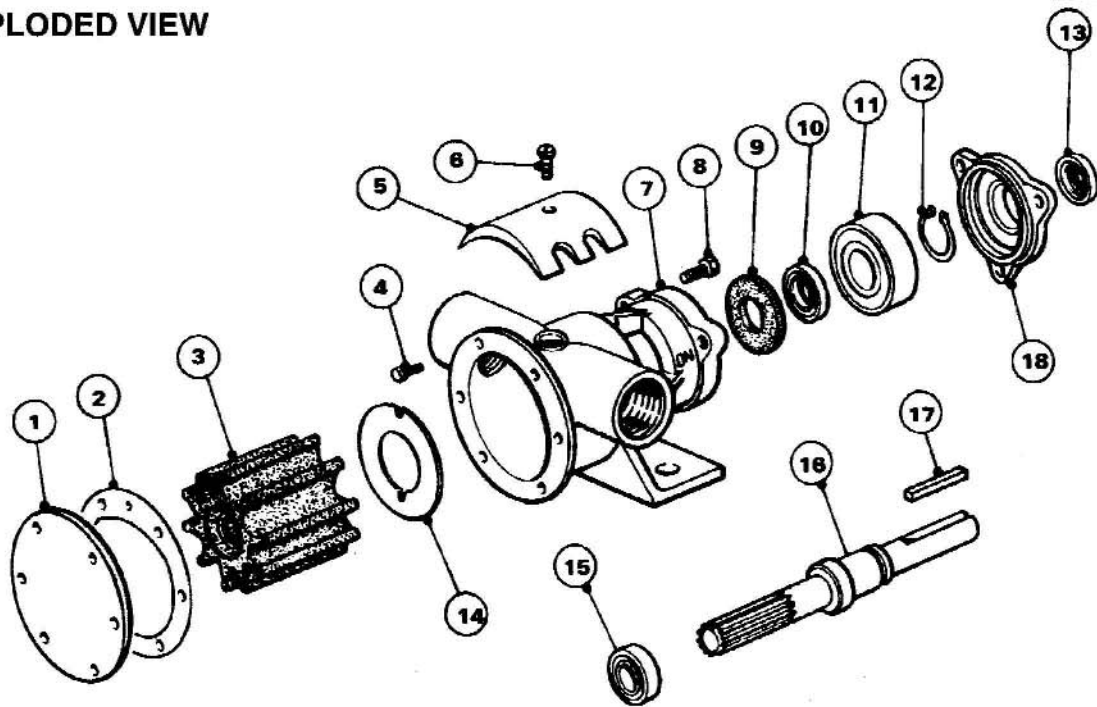

### PARTS LIST MODEL 52080-2001

Key	Description	Qty	Part No	Key	Description	Qty	Part No
1	Endcover	1	3993	10	Inner Bearing Seal	1	SP2700-48
2	Gasket*	1	890	11	Bearing	1	SP2600-06
3	Impeller*	1	17937-0001B	12	Retaining Ring	1	SP1700-247
4	Endcover Screw*	6	X3001-147F	13	Outer Bearing Seal	1	SP2700-1027
5	Cam	1	934	14	Wearplate	1	4156
6	Cam Screw	1	SP1004-09	15	Seal*	1	SP2700-1027
7	Body	1	50084-2100	16	Shaft	1	52087-0000
8	Screw	3	X3003-178F	17	Key	1	X4000-209A
9	Slinger	1	3180	18	Outboard Seal Housing	1	52081-0000
					Spline Seal	1	4345

### Service Kit No SK406-0001

Contains Parts marked\*

#### Options:-

High Pressure Neoprene Impeller  
Nitrile Impeller  
1/2 Cam  
1/2 Cam Screw  
2/3 Cam  
2/3 Cam Screw

Part No 5915-0001B  
Part No 17937-0003B  
Part No 2431  
Part No SP1004-10  
Part No 3255  
Part No SP1004-10

### INSTALLATION DRAWING

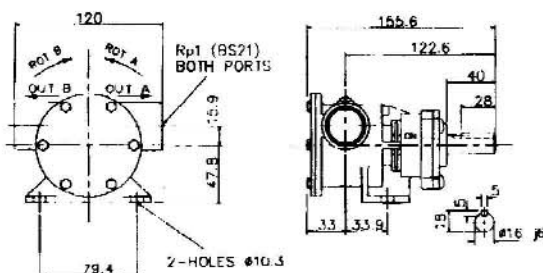

### SERVICE INSTRUCTIONS

**Dis-Assembly** Inspect all parts for wear or damage and replace if necessary

1. Remove endcover screws, endcover and gasket.
2. Remove impeller.
3. Loosen cam screw and remove cam, (clean off old jointing compound).
4. Remove wearplate.
5. Remove lip seal from body.
6. Remove fixing screws and outboard seal housing, together with seal.
7. Press shaft on impeller drive end to remove shaft and bearing from pump. Heating outside of body will ease dis-assembly.
8. Remove bearing retaining ring from shaft.
9. Supporting bearing inner race, press through bearing.
10. Remove inner bearing seal if it needs replacing.

#### Assembly

1. Lubricate inner bearing seal with grease and press into body bearing seal bore with lip facing away from bearing bore.
2. Press shaft into bearing, supporting inner race of bearing. Fit bearing retaining ring onto shaft.
3. Position slinger in body drain area. Insert splined end of shaft through bearing bore and guide slinger over shaft until bearing contacts body. Press on bearing outer race, install bearing into bore.
4. Fit new outer bearing seal in outboard seal housing and fit to pump, securing with retaining screws.
5. Lubricate OD and lip of seal, then push into place using care not to damage or cut seal lip. (Lip faces impeller bore).
6. Fit wearplate, aligning dimple in wearplate with slot in cam.
7. Coat cam screw threads, and top of cam with a nonsetting jointing compound. Install in body.
8. Lightly grease impeller bore and start impeller into bore with a rotary motion until splines engage, then push into bore.
9. Fit endcover and gasket and secure with endcover screw.



### EXPLODED VIEW

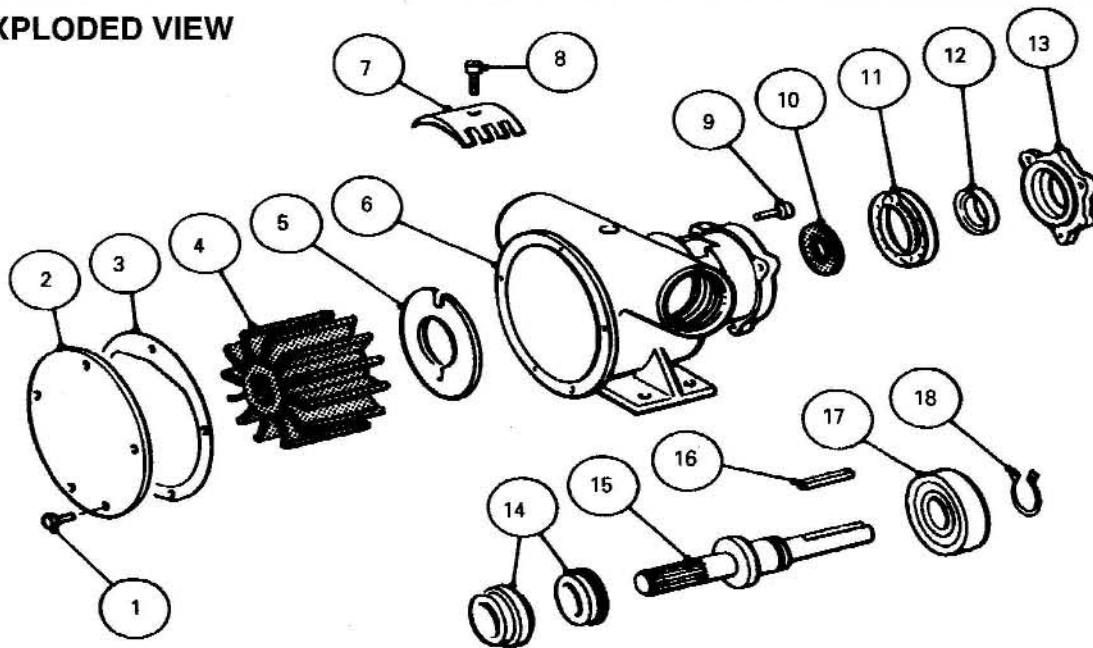

### PARTS LIST MODEL 52200-2011

Key	Description	Qty	Part No	Key	Description	Qty	Part No
1	Endcover Screw*	5	X3001-176F	10	Slinger	1	3181
2	Endcover	1	9336	11	Inner Bearing Seal	1	SP2700-50
3	Gasket*	1	816	12	Outer Bearing Seal	1	SP2701-1013
4	Impeller*	1	17935-0001B	13	Outboard Seal Housing	1	52201-0000
5	Wearplate	1	2574	14	Seal Assembly*	1	21849
6	Body	1	50204-2100	15	Shaft	1	52207-0000
7	Cam	1	834	16	Key	1	X4000-567A
8	Cam Screw	1	SP1005-07	17	Bearing	1	SP2600-04
9	Screw	3	X3003-178F	18	Retaining Ring	1	SP1700-245
					Spline Seal	1	4346

#### Options:-

Std. Pressure Neoprene Impeller  
High Pressure Neoprene Impeller  
Nitrile Impeller

Part No 836-0001B  
Part No 807-1001B  
Part No 17935-0003B  
or 836-0003  
Part No 2551  
Part No SP1005-05

1/2 Cam  
1/2 Cam Screw

#### Service Kit No SK407-0011

Contains Parts marked\*

### INSTALLATION DRAWING

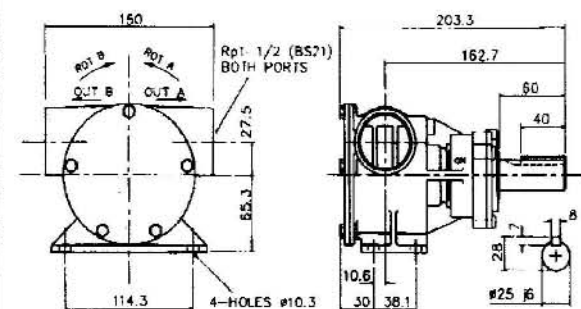

### SERVICE INSTRUCTIONS

**Dis-Assembly** Inspect all parts for wear or damage and replace if necessary

1. Remove endcover screws, endcover and gasket.
2. Remove impeller.
3. Loosen cam screw and remove cam, (clean off old jointing compound).
4. Remove wearplate.
5. Remove seal assembly.
6. Remove fixing screws and outboard seal housing, together with seal.
7. Press shaft on impeller drive end to remove shaft and bearing from pump. Heating outside of body will ease dis-assembly.
8. Remove bearing retaining ring from shaft.
9. Supporting bearing inner race, press shaft through bearing.
10. Remove inner bearing seal if it needs replacing.

#### Assembly

1. Lubricate inner bearing seal with grease and press into body bearing seal bore with lip facing away from bearing bore.
2. Press shaft into bearing, supporting inner race of bearing. Fit bearing retaining ring onto shaft.
3. Position slinger in body drain area. Insert splined end of shaft through bearing bore and guide slinger over shaft until bearing contacts body.
4. Fit new outer bearing seal in outboard seal housing and fit to pump, securing with retaining screws.
5. Fit seal seat and cup rubber, with seal seat facing towards impeller bore. Fit seal with carbon face towards face of seal seat. Replace spacer.
6. Install wearplate in body bore, aligning slot in wearplate with dowel pin in body.
7. Coat cam screw threads, and top of cam with a non setting jointing compound. Install in body.
8. Lightly grease impeller bore and start impeller into bore with a rotary motion until splines engage, then push into bore.
9. Fit endcover and gasket and secure with endcover screws.

### EXPLODED VIEW

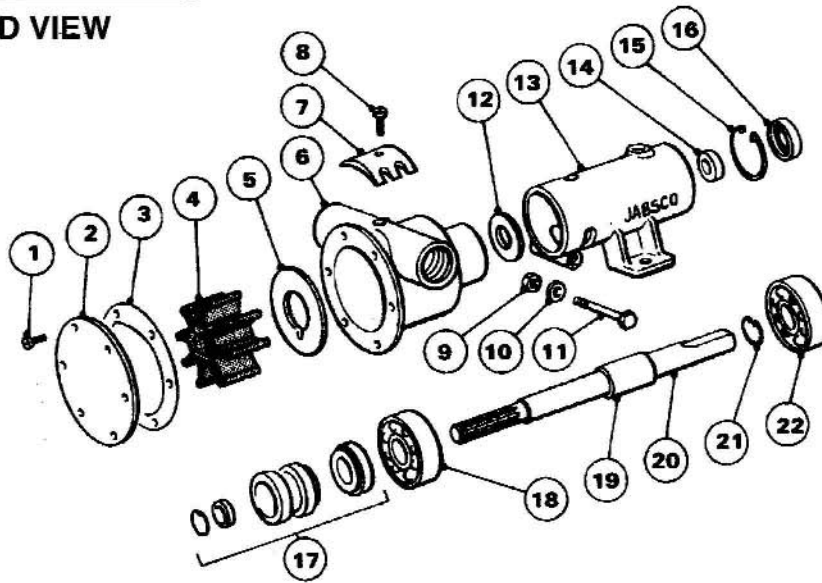

PARTS LIST			Model 10550	Model 9710
Key	Description	Qty	Part No	Part No
1	Endcover Screw*	6	SP1002-02	SP1003-09
2	Endcover	1	3992	3993
3	Gasket*	1	3298	890
4	Impeller*	1	1210-0001B	17937-0001B
5	Wearplate	1	7883	4156
6	Body	1	10554-200	10329-200
7	Cam	1	490	934
8	Cam Screw	1	SP1003-01	SP1004-09
9	Nut	1	SP1105-03	SP1105-03
10	Washer	1	SP1602-06	SP1602-06
11	Bolt	1	SP1095-09	SP1095-09
12	Slinger	1	3286	3180
13	Bearing Housing	1	10557	10330
14	Inner Bearing Seal	1	SP2701-21	SP2701-21
15	Retaining Ring	1	SP1700-248	SP1701-185
16	Outer Bearing Seal	1	SP2701-15	SP2700-47
17	Seal Assembly*	1	22617-0010	22617-0010
18	Ball Bearing	1	SP2601-39	SP2600-38
19	Bearing Spacer	1	9998	-
20	Shaft	1	10417	9717
21	Retaining Ring	1	SP1700-249	-
22	Ball Bearing	1	SP2601-39	SP2600-38
23	Spline Seal	1	4345	4345

#### MODEL 10550-200

Service Kit No SK239  
Contains Parts marked\*

**Options**  
High Pressure  
Neoprene Impeller Part No 3085-0001B  
Nitrile Impeller Part No 1210-0003B  
1/2 Cam Part No 10336  
1/2 Cam Screw Part No SP1003-09

#### MODEL 9710-200

Service Kit No SK 229  
Contains Parts marked\*

**Options:-**  
High Pressure  
Neoprene Impeller Part No 5915-0001B  
Nitrile Impeller Part No 17937-0003B  
1/2 Cam Part No 2431  
1/2 Cam Screw Part No SP1004-10  
2/3 Cam Part No 3255  
2/3 Cam Screw Part No SP1004-10

#### SERVICE INSTRUCTIONS

**Dis-Assembly** Inspect all parts for wear or damage and replace if necessary

1. Remove endcover screws, endcover and gasket.
2. Remove impeller.
3. Loosen cam screw, remove cam, (clean off any old jointing compound).
4. Remove wearplate.
5. Remove seal retaining ring from shaft.
6. Remove pump body from bearing housing by removing holding bolt.
7. Remove spacer and seal assembly.
8. Slide slinger off shaft.
9. Insert screwdriver between OD of outer bearing seal and bearing housing bore and pry out seal.
10. Remove bearing to housing retaining ring.
11. Press shaft on impeller drive end to remove shaft and bearing assembly from pump. Heating outside of body will ease dis-assembly. Remove inner bearing seal. Remove shaft retaining ring model 10550.
12. Support bearing inner race and press shaft through bearing. Repeat procedure for other bearing.

#### Assembly

1. Lubricate inner bearing seal with grease and press into body bearing seal bore with lip facing away from bearing bore.
2. Support inner race of bearing and press shaft through bearing until located against shoulder on shaft. Repeat operation for other bearing.
3. Locate slinger in drain area.
4. Press shaft and bearing assembly into bearing housing, guide slinger onto shaft until located in housing.
5. Fit bearing to body retaining ring.
6. Lubricate outer bearing seal with grease and press into bearing bore until it is flush with the body, (spring facing outwards).
7. Fit pump body, secure with bolt, washer and nut.
8. Fit seal seat and cup rubber, with seal seat facing towards impeller bore.
9. Fit seal with carbon face towards face of seal seat and replace spacer.
10. Fit shaft retaining ring onto shaft, (10550).
11. Install wearplate in body bore aligning slot in wearplate with dowel pin in body.
12. Coat cam screw threads, and top of cam with a non setting jointing compound. Install in body.
13. Lubricate impeller bore with a light coat of good quality water pump grease and start impeller into bore with a rotary motion until splines engage, then push into bore.
14. Replace gasket, endcover and secure with endcover screws.

#### INSTALLATION DRAWING MODEL 10550-200

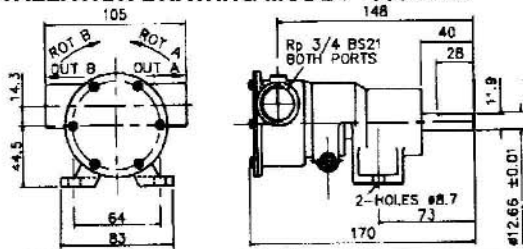

#### INSTALLATION DRAWING MODEL 9710-200

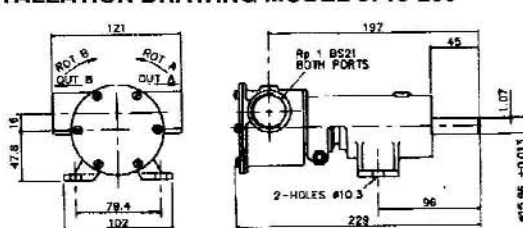

## SERIES { 52220-0 Flanged Ports 52270-0 Flanged Ports 52270-2 BSP Ports

### EXPLODED VIEW

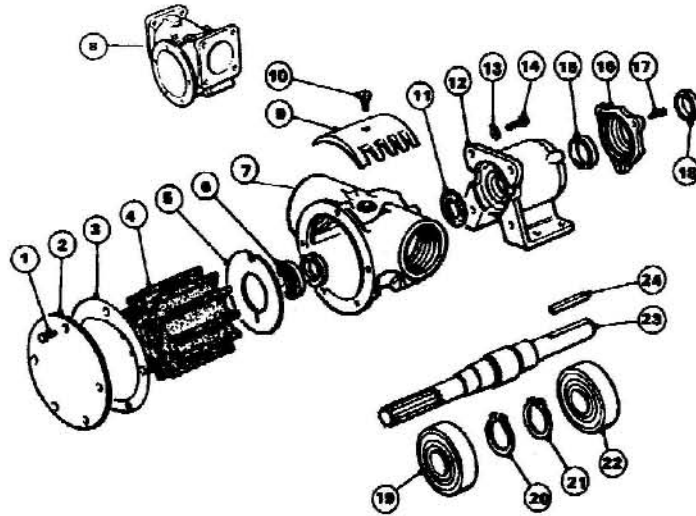

### PARTS LIST

Key	Description	Qty	Part No	Key	Description	Qty	Part No
1	Endcover Screws *	5	SP1095-0640	10	Cam Screw	1	SP1005-04
	52220-0 & 52270-0	5	X3001-176F	11	Slinger	1	X4020-324A
	52270-2	5		12	Bearing Housing	1	50273
2	Endcover	1	9336		Washer		
3	Gasket *	1	816	13	52220-0 & 52270-0	4	SP1602-13
	Neoprene Impeller *				52270-2	4	X3001-209C
	52220-0	1	17935-0001B	14	Bolt		
	52270-0 & -2	1	21676-0001B or 17936-0001B	14	52220-0 & 52270-0	4	SP1095-28
	Nitrile Impeller *				52270-2	4	X3001-209C
	52220-0	1	836-0003B	15	Inner Bearing Seal	1	SP2701-54
	52270-0 & -2	1	21676-0003B or 6760-0003B	16	Outer Seal Housing	1	52201-0000
5	Wearplate	1	2574	17	Screw	3	X3003-178F
6	Seal Assembly *	1	21849	18	Outer Bearing Seal	1	SP2701-1013
	Body			19/22	Bearing	1	SP2601-0458
	52270-2 (BSP)	1	50274-2100	20/21	Retaining Ring	1	Y5026-08
	52220-0 (Flanged)	1	10634		Shaft		
	52270-0 (Flanged)	1	10494	23	52220-0	1	52227-0000
	Cam				52270-0 & -2	1	52277-0000
9	52220-0	1	834	24	Key	1	X4000-567A
	52270-0 & -2	1	6988				

### Port Adaptors [Optional Extra]

Series	Kit No.	Description	Series	Kit No.	Description
52220-0	K1-01	2" I/D Hose	52270-0	K2-01	2-1/2" I/D Hose
	K1-200	1-1/2" BSP		K2-200	2" BSP
	K1	1-1/2" NPT		K2	2" NPT

### 52220-0 Series

Service Kit SK407-0011 contains parts marked \* Neoprene Impeller  
Service Kit SK407-0003 contains parts marked \* Nitrile Impeller

### 52270-0 & 2 Series

Service Kit SK408-0011 contains parts marked \* Neoprene Impeller  
Service Kit SK408-0013 contains parts marked \* Nitrile Impeller

### SERVICE INSTRUCTIONS

**Dis-Assembly** Inspect all parts for wear or damage and replace if necessary

1. Remove endcover screws, endcover and gasket.
2. Remove impeller.
3. Loosen cam screw and remove cam, (clean off any old jointing compound).
4. Remove wearplate.
5. Remove bolts from bearing housing to body, separate pump body from bearing housing.
6. Remove seal assembly from body.
7. Remove fixing screws and outboard seal housing together with seal.
8. Press shaft on impeller drive end to remove shaft and bearings from housing. Heating outside of body will ease dis-assembly.
9. Support bearing inner race and press shaft through bearing. Repeat procedure for other bearing.
10. Remove inner bearing seal if it needs replacing.

### Assembly

1. Lubricate inner bearing seal with grease and press into body bearing seal bore with lip facing away from bearing bore.
2. Fit retaining rings onto shaft and press on bearings.
3. Grease seal area of shaft, push bearings and shaft into bearing housing by pressing on outer race of bearing.
4. Fit outer bearing seal into the outboard seal housing and fit to bearing housing, securing with retaining screws.
5. Place slinger on shaft.
6. Fit pump body to bearing housing securing with 4 bolts.
7. Fit seal seat and cup rubber, with seal seat facing towards impeller bore. Fit seal with carbon face towards face of seal seat.
8. Install wearplate in body bore aligning slot in wearplate with dowel pin in body.
9. Coat cam screw threads and top of cam with a non setting jointing compound. Install in body.
10. Lubricate impeller bore with a light coat of pump grease and start impeller into bore with a rotary motion until splines engage, then push into bore.
11. Replace gasket, endcover and secure with endcover screws.

### INSTALLATION DRAWING

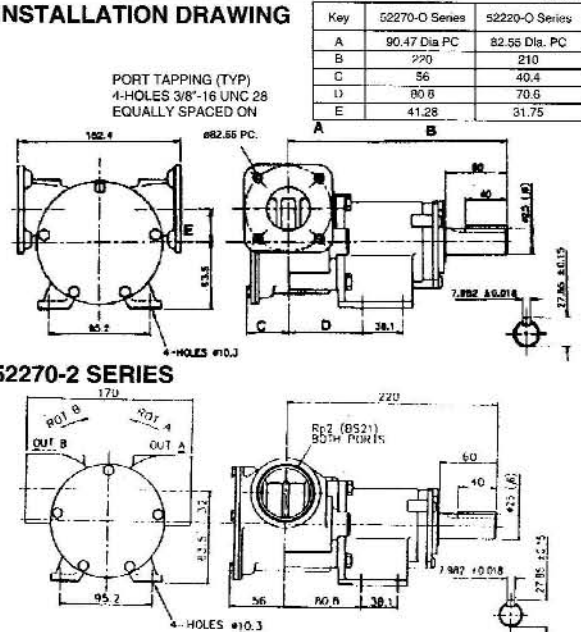

### EXPLODED VIEW

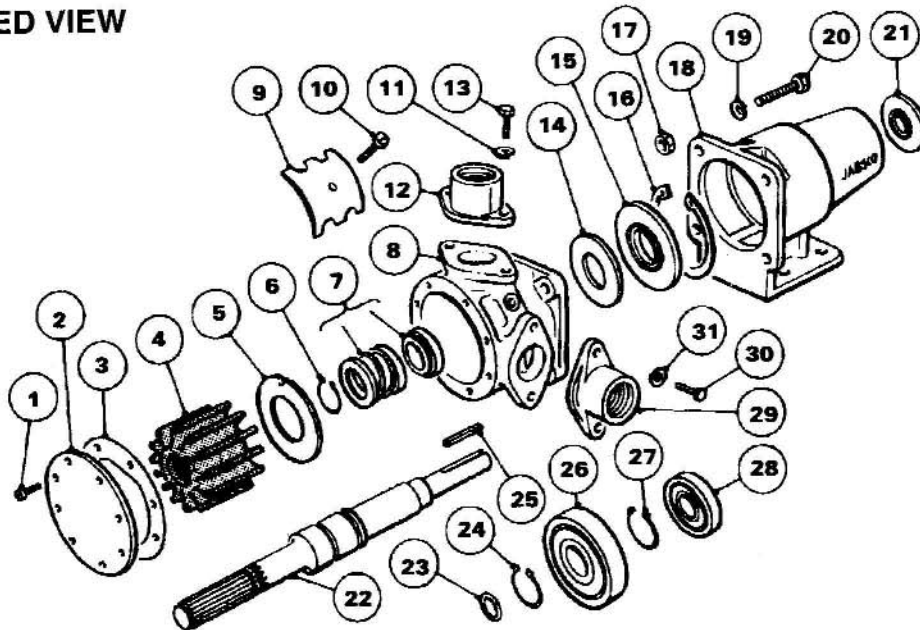

Pump now obsolete - Data for spare Parts Only

### PARTS LIST 9440-200

Key	Description	Qty	Part No	Key	Description	Qty	Part No
1	Endcover Screw*	8	SP1006-05	17	Nut	4	SP1085-15
2	Endcover	1	9448	18	Bearing Housing	1	3206
3	Gasket*	1	3209	19	Lock Washer	4	SP1808-02
4	Impeller*	1	2999-0001B	20	Bolt	4	SP1095-29
5	Wearplate	1	9316	21	Bearing Seal	1	SP2700-58
6	Retaining Ring	1	SP1700-143	22	Shaft	1	3207
7	Seal Assembly*	1	9309	23	'O' Ring*	1	SP2000-54
8	Body	1	9414	24	Retaining Ring	1	SP1700-196
9	Cam	1	9446	25	Key	1	9214
10	Cam Screw	1	SP1006-03	26	Ball Bearing	1	SP2600-16
11	Lock Washer	2	SP1608-04	27	Retaining Ring	1	SP1700-196
12	Port Adaptor	1	9443	28	Ball Bearing	1	SP2600-15
13	Bolt	2	SP1095-30	29	Port Adaptor	1	9443
14	Slinger	1	3212	30	Bolt	2	SP1095-30
15	Bearing Seal	1	SP2700-59	31	Lock Washer	2	SP1608-04
16	Retaining Ring	1	SP1701-433				

Service Kit SK207 contains Parts marked\*

### SERVICE INSTRUCTIONS

**Dis-Assembly** Inspect all parts for wear or damage and replace if necessary

1. Remove endcover screws, endcover and gasket.
2. Remove impeller using extractor supplied with pump. The two bolts in the extractor locate into two holes in impeller hub. Screw centre bolt to extract impeller.
3. Loosen cam screw and remove cam, (cleaning off any old jointing compound).
4. Remove wearplate.
5. Remove 'O' ring and retaining ring to remove seal assembly. Note: If this proves difficult, remove pump body from the bearing housing by unfastening the four retaining bolts, then press out seal assembly from the pump body.
6. Remove slinger.
7. Remove the bearing seal using a small screwdriver by levering at the outer diameter of the seal. Do not touch the lip of the seal.
8. Remove retaining ring from the bearing housing.
9. Remove key from shaft and remove burrs from shaft area. Remove the outer bearing seal and then press shaft and bearing assembly towards impeller end.
10. Press shaft through the smaller bearing whilst supporting the inner race of the bearing.
11. Remove the retaining rings of the larger bearing and press shaft through the bearing towards the impeller end whilst supporting the inner race of the bearing.

### Assembly

1. Fit the retaining ring for the larger bearing at the impeller end of shaft.
2. Press shaft through the larger bearing until the bearing touches the retaining ring, whilst supporting the inner race of the bearing, do not force the bearing against the retaining ring.
3. Fit the second retaining ring.
4. Press shaft in the smaller bearing whilst supporting the inner race.
5. Press shaft and bearing into the bearing housing.
6. Fit retaining ring into bearing housing.
7. Fit the larger lip seal. Press seal of the smaller bearing flush with the end of the bearing housing. Take care that seals are installed with the springs face away from the bearings.
8. Fit slinger to the shaft.
9. Fit pump body to the bearing housing by its four fixing bolts.
10. Replace seal seat and 'O' rings. Install seal assembly with carbon face against seal seat. Compress the spring with the spring washer and install the retaining ring.
11. Coat cam screw threads and top of cam with a non setting jointing compound. Install in body.
12. Lightly grease the walls of impeller bore and the shaft splines with a good quality grease. Push impeller into pump bore with a rotary motion in the direction of the rotation of the pump, whilst exerting pressure with the hand palm until the impeller splines engage with the shaft splines. Note: To ease assembly use a wooden mallet and block of wood; it is possible to complete the installation of the impeller with not more than 1/2" protruding from the pump by tightening the endcover screws.
13. Fit gasket, endcover screws and endcover.

### INSTALLATION DRAWING

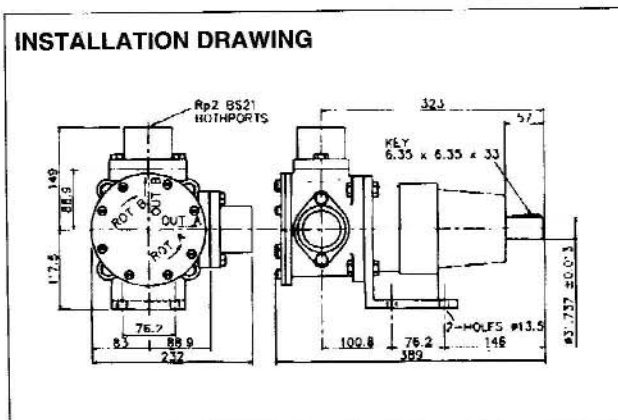



### EXPLODED VIEW

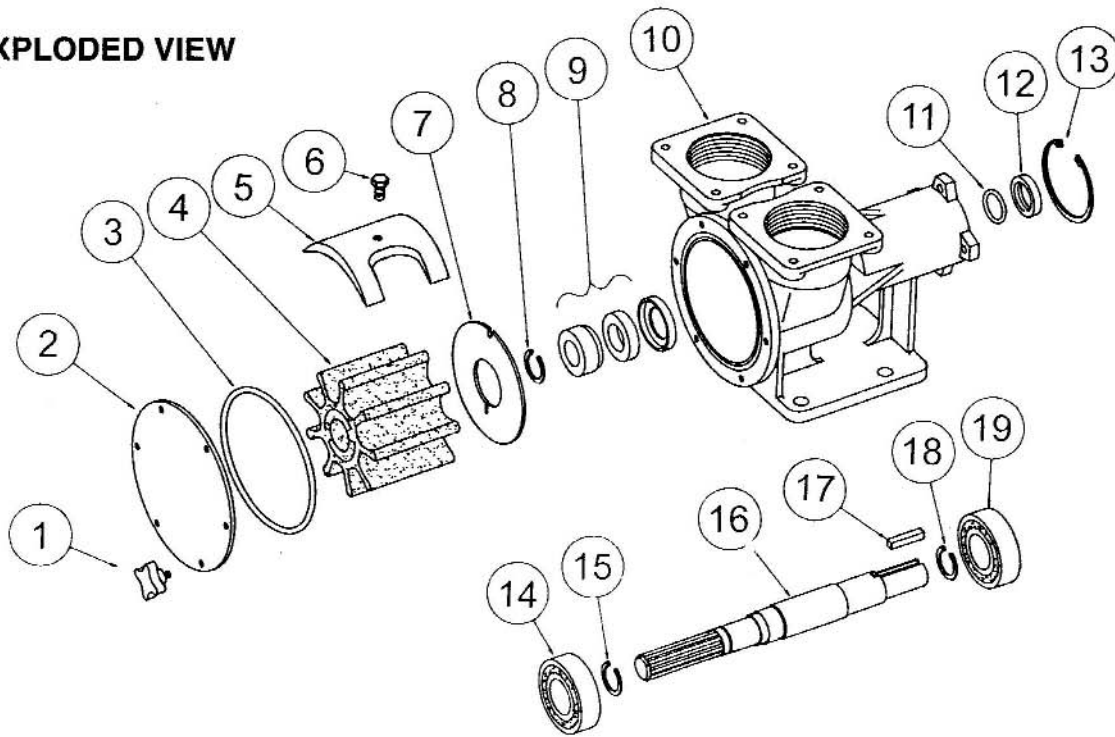

### PARTS LIST MODEL 29860-2201

Key	Description	Qty	Part No
1	Endcover Screws	4	X5255-002
2	Endcover	1	29865-0000
3	'O' Ring *	1	X4020-424A
4	Impeller *	1	17240-0001B
5	Cam	1	29862-0200
6	Cam Screw	1	X3001-207F
7	Wearplate	1	29866-0000
8	Retaining Ring	1	SP1700-3015
9	Seal Assembly *	1	21849
10	Body	1	29864-2000
11	Slinger	1	X4020-324A
12	Bearing Seal	1	SP2701-54
13	Retaining Ring	1	SP1701-244
14	Bearing	1	SP2601-0458
15	Retaining Ring	1	SP1700-3014
16	Shaft	1	29867-0000
17	Key	1	X5271-002
18	Retaining Ring	1	SP1700-3014
19	Bearing	1	SP2601-0458

Service Kit No SK412-0001 Contains Parts marked \*

### SERVICE INSTRUCTIONS

**Dis-Assembly** Inspect all parts for wear or damage and replace if necessary

1. Remove endcover screws, endcover and 'O' ring.
2. Remove impeller.
3. Loosen cam screw and remove cam, (clean off old jointing compound).
4. Remove wearplate and retaining ring.
5. Remove seal and assembly.
6. Remove retaining ring.
7. Press on impeller drive end of shaft to remove shaft and bearing assembly and Catch Slinger from body drain area.
8. Remove Bearing Seal.
9. Inspect Bearings, replace if worn.

### Assembly

1. Lubricate bearing seal with grease and press into body bearing seal bore with lip facing away from bearing bore.
2. Push bearings onto shaft and up against retaining rings.
3. Position slinger in body drain area. Insert impeller end of shaft and Bearing Assembly through bearing bore and guide slinger over shaft until bearings contact body.
4. Press on bearing outer race, install bearings into bore.
5. Install retaining ring in body groove.
6. Lubricate OD of Cup Rubber and Seat Assembly, then push into place taking care not to damage. Lubricate Rotary Seat Bore and slide over shaft in place. Fit retaining Ring.
7. Install wearplate in body bore, aligning dimple in wearplate with slot in body.
8. Coat screw threads, and top of cam with a non setting jointing compound. Install in body. Wipe off excess.
9. Lubricate impeller bore with a light coat of good quality grease and start impeller into Body with a rotary motion until splines engage, then push into Body bore.
10. Install 'O' Ring and endcover and secure with endcover screws.

### INSTALLATION DRAWING

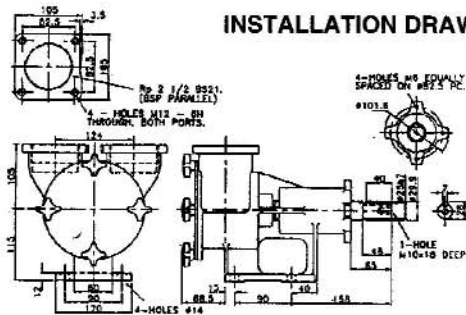

### EXPLODED VIEW

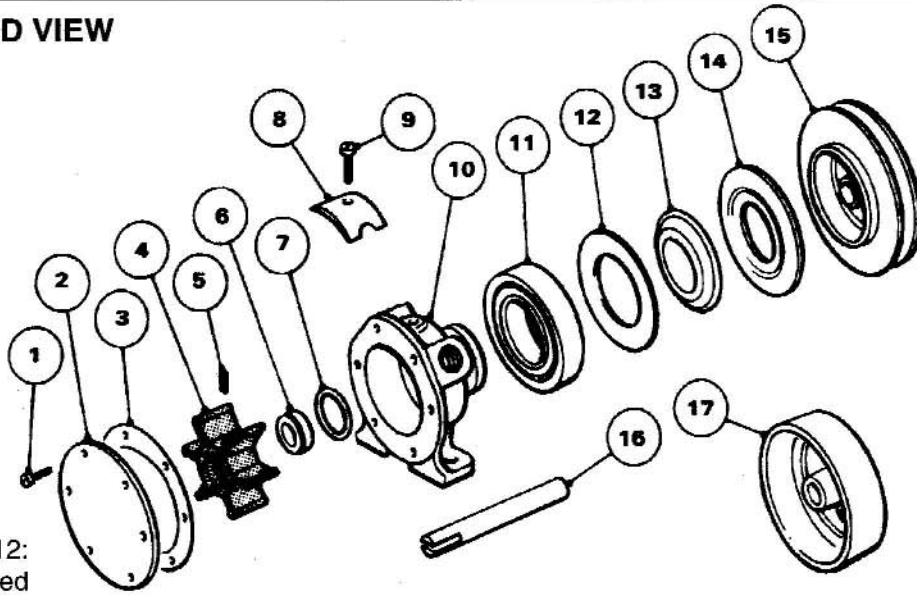

Note Key 7:12:  
no longer fitted

### PARTS LIST

Key	Description	Qty	Part No
1	Endcover Screws*	6	SP1002-02
2	Endcover	1	3992
3	Gasket*	1	2995-0030
4	Impeller*	1	673-0001B
5	Impeller Screw*	1	SP1010-06
6	Seal*	1	SP2700-05
7	'O' Ring*	1	SP2000-43
8	Cam: 2620-200,-252,-253	1	2907-0001
	1/2 Cam:2620-254,-255		2441
9	Cam Screw 2620-200,-252,-253	1	SP1002-09
	1/2 Cam Screw 2620-254,-255		SP1010-06
10	Body	1	2438-200
11	Ball Bearing	1	SP2600-09
12	Rotating Shield	1	1161
13	Stationary Slinger	1	1554
14	Bearing Shield	1	3078
15	Pulley:2620-252,-254	1	10759
	Pulley:2620-253,-255		9487-03
16	Shaft:2620-200	1	688-21-24
	Shaft:2620-252,-253,-254 -255		355-07-24
17	Bearing Housing 2620-200 (only)	1	345

Service Kit SK20 Contains Parts marked \*

### INSTALLATION DRAWING

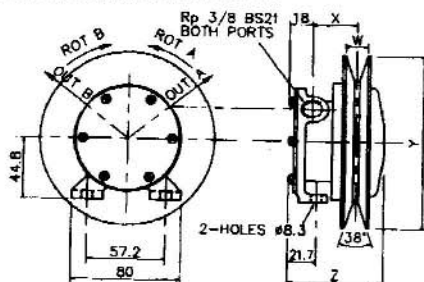

Model	W	X	Y	Z	Note: 2620-200 Overall Dimensions. L:101mm;W:88mm;Ht:100mm For detailed information contact distributor or factory
2620-252	13.3	32.5	127	68.3	
2620-253	16.6	24	159	71	
2620-255	16.6	24	159	71	

### SERVICE INSTRUCTIONS

**Dis-Assembly** Inspect all parts for wear or damage and replace if necessary

1. Remove endcover screws, endcover and gasket.
2. Remove impeller.
3. Remove seal, seal spacer and "O" ring using two pieces of hooked wire.
4. Loosen cam screw, remove cam, (clean off any old jointing compound).
5. Remove pulley from bearing, heating o.d. of pulley uniformly with a gas flame.
6. Remove stationary slinger and rotating shield.
7. Remove bearing (see fig 1). Attach two forks on bearing 180 degrees apart. Tighten extractor screw against plug, extracting bearing. Plug should be solid steel 7/8" o.d. x 9/16" long with one end slightly countersunk to match extractor screw.
8. Remove bearing shield.

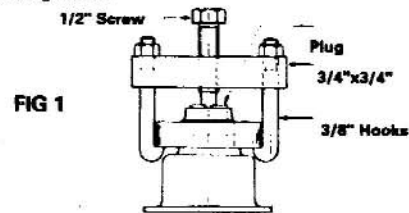

### Assembly

1. Install bearing shield over bearing shoulder with lip facing away from pump body.
2. Press bearing on body until it bottoms. Note: Press on inner race of bearing whilst supporting the pump at the impeller end.
3. Install rotating shield with dimple facing away from bearing. Install stationary slinger with recess away from bearing.
4. Heat pulley to approximately 135°C in oven and drop over bearing. Pulley will immediately shrink upon contact with bearing therefore it must be positioned quickly. Take care not to "cock" the housing. Apply slight pressure to the pulley whilst cooling. Note: An ordinary domestic oven can be used. Approximately 10-15 minutes in oven at full power will usually heat the housing sufficiently.
- 4a. If shaft was removed, support pulley on a suitable fixture and a new shaft in a suitable bush in the pump body. Press shaft into correct position.
5. Coat cam screw threads and top of cam with a non setting compound. Install in body.
6. Fit "O" ring and seal spacer. Note: If original shaft is being refitted and shaft is worn do not replace seal spacer.
7. Lightly grease shaft. Place seal over shaft, using a rotary motion to avoid cutting the seal lip with spring facing outwards. Make sure that the seal is pushed right home.
9. Install impeller assembly on shaft with a rotary motion until screw engages slot in shaft. Then push into bore.
10. Install gasket, endcover, and secure with endcover screws.

### EXPLODED VIEW

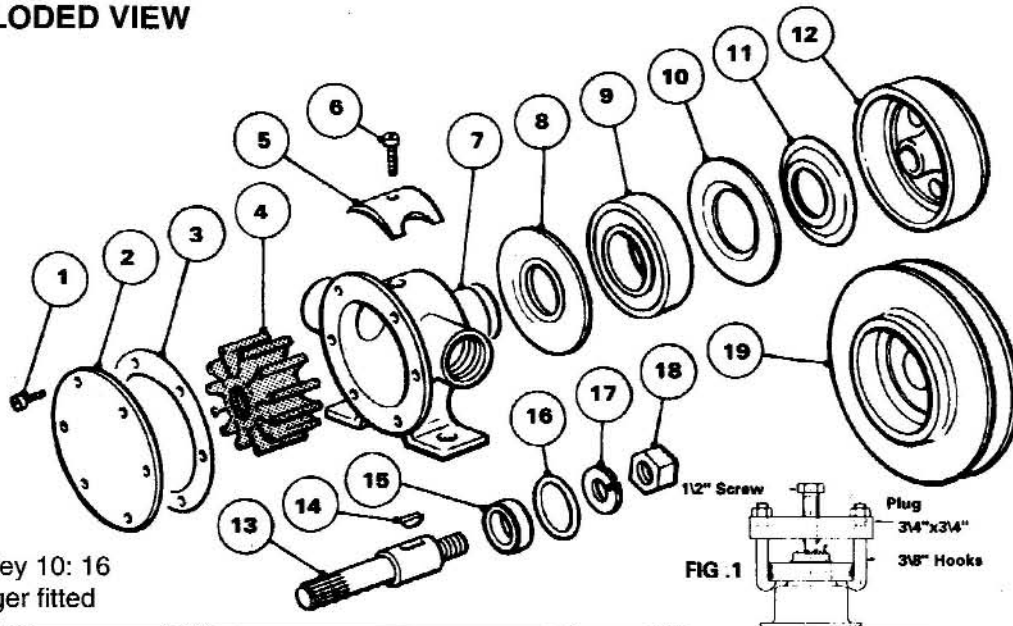

Note Key 10: 16  
no longer fitted

FIG. 1

### PARTS LIST

Key	Description	Qty	Part No	Key	Description	Qty	Part No
1	Endcover Screw†	6	SP1003-09	12	Bearing Housing (Models 6490-200, -205)	1	1740
2	Endcover	1	3993	13	Shaft: 6490-122 to 231		1737-207*
3	Gasket†	1	6496		Shaft: 6490-200, -205		1737-24-01
4	Impeller†	1	1210-0001B	14	Key	1	SP1402-06*
5	1/2 Cam: 6490-210, -222, -223	1	490	15	Shaft Seal†	1	SP2701-21
	-122, -123, -200			16	'O' Ring	1	SP2000-21
	Cam: 6490-231, -224, -225			17	Seal Spacer	1	3186
	-124, -125, -205			18	Nut	1	SP1085-25*
6	Cam Screw (490 Cam)	1	SP1003-01		Pulley 6490-210, -231		9487-05
	Cam Screw (10336 Cam)	1	SP1003-09	19	Pulley 6490-122, -124, -222, -224	1	22299*
7	Body	1	6494-200	4	Pulley: 6490-123, -125, -223, -225		22296*
8	Bearing Shield	1	3078	20	Lockwasher (Not shown)	1	SP1607-04
9	Ball Bearing	1	SP2600-09	Service Kit No SK 255-01 Contains Parts marked†			
10	Rotating Shield	1	1161				
11	Stationary Slinger	1	1554				

### SERVICE INSTRUCTIONS

**Dis-Assembly** Inspect all parts for wear or damage and replace if necessary

- Remove endcover screws, endcover and gasket.
- Remove impeller.
- Remove shaft retaining nut from pulley and remove shaft.
- Remove seal, seal spacer and "O" ring using two pieces of hooked wire.
- Loosen cam screw and remove cam, (clean off any old jointing compound).
- Remove pulley from bearing, heat o.d. of pulley uniformly with gas flame.
- Remove stationary slinger and rotating shield.
- Remove bearing (see fig 1). With shaft and bearing housing removed according to serve instructions, insert plug as shown. Attach two forks on bearing 180 degrees apart. Tighten extractor screw against plug, extracting bearing. Plug should be solid steel 7/8" o.d. x 9/16" long with one end slightly countersunk to match extractor screw.
- Remove bearing shield.

**\* To update obsolete models replace shaft and pulley**

Shaft 1737-224 Replace by shaft 1737-207, key SP1402-06, Nut SP1085-25  
 Pulley 10758 Replace by pulley 22299 for Models 6490-152, -252, -154, -254  
 Pulley 9487-04 Replace by pulley 22298 for Models 6490-153, -253, -155, -255  
 Note: Replacement shaft for models 6490-200 & 205 is Part No 1737-24-01, Key locknut & washer not required.

### INSTALLATION DRAWING

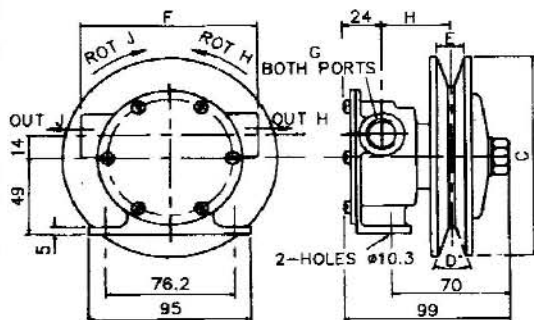

Model No	PULLEY DETAILS					PORT DETAILS		
	PCD for Belt Section	ØØ	Angle	Width	Width	Port		
6490-122	103	117	-	127	38°	17	156	25mm dia Tube
6490-123	135	149	-	159	38°	17	156	25mm dia Tube
6490-210	-	-	155	159	36°	10	106	1/2" BSP
6490-222	103	117	-	127	38°	17	105	1/2" BSP
6490-223	135	149	-	159	38°	17	105	1/2" BSP

Note: 6490-200  
 Overall Dimensions  
 L: 111mm  
 W: 105mm  
 H: 92mm  
 Other Dimensions  
 Contact Distributor  
 or Factory  
 H  
 (c) 127 = 31.8  
 (c) 127 = 41.3

### Assembly

- Install bearing shield over bearing shoulder with flange facing away from impeller.
- Press bearing on body until it bottoms. Note: Press on inner race of bearing whilst supporting the pump at the impeller end.
- Install rotating shield with dimple facing away from bearing. Install stationary slinger, with recessed side away from bearing.
- Heat pulley to approximately 135°C in oven and drop over bearing. Pulley will immediately shrink upon contact with bearing therefore it must be positioned quickly. Take care not to "cock" the housing. Apply slight pressure to the pulley whilst cooling. Note: An ordinary domestic oven can be used. Approximately 10-15 minutes in oven at full power will usually heat the housing sufficiently.
- Coat cam screw threads and top of cam with a non setting compound. Install in body.
- Refit shaft and key from front end of pump and secure to pulley with nut and washer.
- Fit "O" ring and seal spacer. Note: If original shaft is being refitted and shaft is worn do not replace seal spacer.
- Lightly grease shaft splines, place seal over shaft, with spring facing towards impeller. Make sure that the seal is pushed right home.
- Install impeller assembly on shaft with a rotary motion until splines engage then push into bore.
- Install gasket, endcover, and secure with endcover screw.

# INSTALLATION/OPERATION AND SAFETY ADVICE

## INSTALLATION AND OPERATION

**PUMP MAY BE MOUNTED** in any position. When installed vertically motor must be above the pump.

**THE ROTATION OF THE PUMP SHAFT** determines the location of the pump inlet/ports: refer to installation drawing.

**BEFORE INSTALLING** rotate pump shaft and impeller in the direction of the required operation.

**ALL PUMP PIPEWORK** must be adequately supported to avoid stress on pump and pump components and consequential leakage.

**BELT DRIVEN PUMPS** excessive drive belt tension will cause rapid belt wear and may result in premature bearing failure. It should be possible to deflect a correctly tensioned belt between pulleys about 16mm per metres of span by applying finger pressure. Ideally, the contact area should be about 120° but not less than 90°.

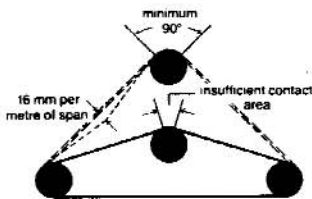

**CRANK SHAFT MOUNTED PUMPS** a torque arm must be fitted and designed so that only pure torque reaction will result. Other unnecessary loads must be avoided.

### OPERATION

Pump should not be operated above its published performance without referring to distributor.

### AC MOTOR PUMP UNITS

**ALL ELECTRICAL WIRING** should be connected and installed by a competent electrician. A qualified person must ensure that the installation conforms to the Electrical and Mechanical requirements of Local and National Regulations. All equipment operating within a flame proof area must comply with the relevant standards applying to that area. Before using the pump, ensure that your electrical supply corresponds with the voltage range marked on the machine.

**WARNING - THIS APPLIANCE MUST BE EARTHED UNLESS SPECIFIED** motors are not flame proof and can spark, explosion and death can occur.

**LABELS** should be attached to all services over 60°C, indicating "Hot Areas". Where capacitors are employed in motor circuits, a charge is retained after the supply has been isolated. This must be discharged before touching motor terminations to avoid the risk of an electrical shock.

**TEMPERATURE:** Operating range

Neoprene Impellers 4-80°

Oil resistant impellers 10-90°

Pumps: are dry self-priming i.e. do not require to be filled with liquid to start up.

**Running Dry:** Unit depends on liquid pumped for lubrication. A dry running period of up to 30 seconds on initial prime is generally as a safe length of time. If pump has not been primed after 30 seconds, stop and check for airleaks in pipe work, and impeller, seal or gasket damage.

## SAFETY ADVICE

Ensure that all moving parts are adequately guarded to prevent accidental contact. Leakage from mechanical seal or gland could cause a hazard. If liquids being pumped are toxic or corrosive, use of a drip tray is recommended.

**DO NOT USE** for Petrol, Toluene, Benzene or light fraction petroleum products such as solvents, thinners or other liquids with flashpoint below 37°C.

**FREEZING temperatures** - do not permit liquid to freeze in pump body. Drain pump by loosening end cover.

**IT IS A REQUIREMENT OF COSHH (1988) REGULATIONS THAT THE MANUFACTURER'S INSTRUCTIONS IN THE HANDLING OF HAZARDOUS SUBSTANCES MUST BE OBSERVED AT ALL TIMES.**

To confirm with the Health and Safety and COSHH Regulations, ITT Jabsco require that any pump or part of a pump that is returned to this company for repair or examination, or for any reason whatsoever, will be suitably packed and accompanied by a letter stating what the pump/part has been pumping.

If the liquid or product is hazardous or in any way dangerous, this must be stated and the chemical make-up of it must be stated in detail.

Unless this procedure is observed the unit will not be accepted on our company premises. The only exception to this rule is if the pump returned is new and unused.

Jabsco



ITT Industries

Jabsco, 20 Icon, Foothill Ranch, CA 92610

Tel : +1 949 609 5106

Fax : +1 949 859 1153

USA

Jabsco, Bingley Road, Hoddesdon, Hertfordshire, EN11 0BU

Tel : +44 (0) 1992 450 145

Fax : +44 (0) 1992 467 132

UK

Fluid Products Canada, 55 Royal Road, Guelph, Ontario N1H 1T1

Tel : +1 519 821 1900

Fax : +1 519 821 5316

CANADA

NHK Jabsco Co Ltd, 3-21-10, Shin - Yokohama, Kohoku-ku, Yokohama 222

Tel : +81 (0) 45 475 8906

Fax : +81 (0) 45 475 8908

JAPAN

Jabsco GmbH, Oststraße 28, 22844 Norderstedt

Tel : +49 (0) 40 53 53 73 0

Fax : +49 (0) 40 53 53 73 11

GERMANY

Warranty: All products of the company are sold and all services of the company are offered subject to the company's warranty and terms and conditions of sale, copies of which will be furnished upon request. The information provided herein is for guidance only, it does not constitute a guarantee of the performance or specification of any individual product or component.  
©Copyright 2003 ITT Industries