

**JABSCO**[®]

Models 6400-Series 7420-Series

SELF-PRIMING PUMPS

FEATURES

Body:	Bronze
Impeller:	Neoprene
Shaft:	Bronze
Wearplate:	Replaceable
Shaft Seal:	Carbon-Ceramic Face Type
Bearing:	Pre-lubricated Double Row Ball
Ports:	1-1/4" NPT Internal
Weight:	10-1/2 lb (4,8 kg) approx.

VARIATIONS AVAILABLE

MODEL NO.	DESCRIPTION
6400-0004	Full Thickness Cam, Neoprene Impeller, Standard Shaft
6400-0051	Half Thickness Cam, Neoprene Impeller, Standard Shaft
6400-1051	Half Thickness Cam, Neoprene Impeller, Short Shaft
7420-0004	Full Thickness Cam, Neoprene Impeller, Standard Shaft
7420-1001	Full Thickness Cam, Neoprene Impeller, Short Shaft

APPLICATIONS

MARINE: Pumping bilges, Washdown, Engine Cooling.

INDUSTRIAL: Circulating and Transferring liquids; Velocity-mixing; Transferring soap, liquors, pastes, glues, glycerine, lotions and brine.

FARM: Pumping water for stock and poultry houses and Booster Pumping.

PLUMBING & HOME: Pumping out flooded basements, cesspools, sumps and many other uses.

OPERATING INSTRUCTIONS

1. **INSTALLATION** - Pump may be mounted in any position. The rotation of the pump shaft determines the location of the pump's intake and discharge ports. (Refer to dimensional drawing.) Pump is normally assembled at factory for clockwise rotation (looking at end cover). If counter clockwise rotation is desired, follow steps 1 and 2 of disassembly and step 12 of assembly instructions to change direction of impeller blade deflection under cam.

2. **DRIVE** - Belt or Direct with flexible coupling.



Exposed pulleys and belts can cause injury. Install shield around pulleys and belts.

DIRECT DRIVE - Clearance should be left between drive shaft and pump shaft when installing coupling. Always mount and align pump and drive shaft before tightening the coupling set screw.

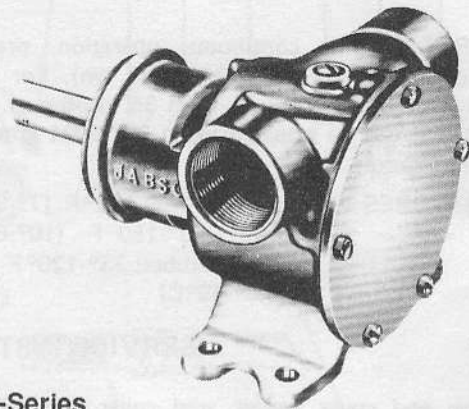

6400-Series

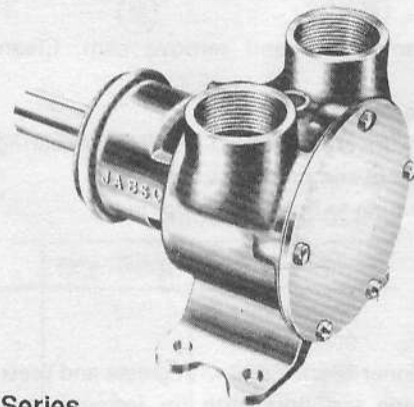

7420-Series

Models 6400-Series, 7420-Series

NOTICE: If drive pulley or coupling must be pressed on shaft, remove end cover and impeller and support shaft from impeller end during press operation. Do not hammer a pulley or coupling on shaft. Failure to follow above instructions can damage the pump.

- SPEEDS** - 100 RPM to the maximum shown in the performance table. For longer pump life, operate at lowest possible speeds.
- SELF-PRIMING** - Primes at low or high speeds. For vertical dry suction lift of 10 feet, (3,1m) a minimum of 800 RPM is required. Pump will produce suction lifts up to 22 (6,7m) feet when wetted. **BE SURE SUCTION LINES ARE AIRTIGHT.**
- RUNNING DRY** - Unit depends on liquid pumped for lubrication. **DO NOT RUN DRY** for more than 30 seconds. Lack of liquid will damage the impeller.

ITT Jabsco

ITT Fluid Technology Corporation
1485 Dale Way, P.O. Box 2158, Costa Mesa, CA 92628-2158
Tel: (714) 545-8251; Fax: (714) 957-0609
Bingley Road, Hoddesdon, Hertfordshire EN11 0BU England
Tel: 0992-467191; Tlx: 263251 G; Fax: 0992-467132

OPERATING INSTRUCTIONS

6. **NOTICE** — If pumping light fraction petroleum derivatives, solvents, thinners, highly concentrated or organic acids, consult Jabsco "Chemical Resistance Table" (which is available upon request from ITT Jabsco) for proper body materials and impeller compounds. If corrosive fluids are handled, pump life will be prolonged if pump is flushed with water after each use or after each work day.
7. **PRESSURES** — For continuous operation, pressure should not exceed 30 p.s.i. (2,1 kg/sq cm). For intermittent service only, pressures from 35 to 50 p.s.i. (2,5-3,5 kg/sq cm) can be attained using 807-1001 impeller, plus an extra gasket.
8. **TEMPERATURES** — Neoprene: 45°-180°F (7°-82°C)
Nitrile: 50°-180°F (10°-82°C)
Natural Rubber: 33°-120°F (0,6°-49°C)
9. **FREEZING TEMPERATURES** — Drain unit by loosening end cover. The following anti-freeze compounds can be used without any adverse effect to the neoprene impeller: Atlas "Permaguard", DuPont "Zerex" and "Telar", Dow Chemical "Downguard" and Olin Mathison "Pyro". Most methyl alcohol (methanol) based anti-freezes can be used. **DO NOT USE PETROLEUM BASED ANTI-FREEZE COMPOUNDS OR RUST INHIBITORS.**
10. **GASKET** — Use standard pump part. A thicker gasket will reduce priming ability. A thinner gasket will cause impeller to bind. Standard gasket is 0.015" thick.
11. **SPARE PARTS** — To avoid costly shut downs, keep a Jabsco Service Kit on hand.

SERVICE INSTRUCTIONS DISASSEMBLY

1. Remove end cover screws, end cover and gasket.
 2. Remove impeller.
 3. Remove seal with hooked wire. Remove seal seat and gasket.
 4. Loosen cam screw and remove cam. Clean off sealant.
 5. Remove wearplate.
 6. Insert screwdriver between O D of outer bearing seal and pump bore and pry out seal.
 7. Remove bearing to body retaining ring.
 8. Press on impeller drive end of shaft to remove shaft and bearing assembly. Heating outside of body at bearing will ease disassembly.
 9. Remove bearing-to-shaft retaining ring.
 10. Supporting bearing inner race, press shaft through bearing.
 11. Using extreme care not to mar body bore, insert screwdriver between O D of inner bearing seal and pump bore and pry out the seal.
- NOTE:** Inspect all parts for wear or damage and replace if necessary.

ASSEMBLY

1. Lubricate inner bearing seal with grease and press into body bearing seal bore with lip facing away from bearing bore.
2. Press shaft into bearing, using care to support inner race of bearing.
3. Install bearing to shaft retaining ring with flat side toward bearing.
4. Position slinger in body drain area. Insert splined end of shaft through bearing bore and guide slinger over shaft until bearing contacts body.
5. Pressing on bearing outer race, install bearing and shaft assembly into bore.
6. Install bearing to body retaining ring in body groove with flat side toward bearing.
7. Lubricate outer bearing seal with grease and press into bearing bore until it is flush with the body.
8. Install wearplate in body bore, aligning slot in wearplate with dowel pin in body.
9. Apply a thin coat of sealant to cam screw threads and top side of cam and install in body.
10. Lubricate seal seat assembly with water and insert in seal bore of body with polished surface facing outward. Care must be taken not to mar or scratch seal seat face. Installing this assembly with a slight rotary motion will insure seating the gasket firmly in the cavity.

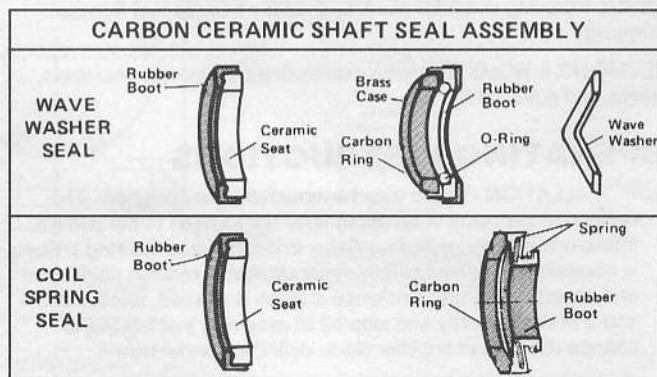

11. In this pump, either a wave washer seal or coil spring seal may be used. The wave washer is used only if the carbon portion of the seal does not have a coil spring attached. Slide carbon ring assembly, with carbon facing ceramic, over the shaft and firmly up against the ceramic seat. If carbon portion of seal does not have an integral coil type tensioning spring, slide wave washer over the shaft and against the rubber boot on metal case containing O-ring and carbon.
12. Lubricate impeller bore with a light coat of water pump grease and start impeller into bore with a rotary motion until splines engage, then push into bore.
13. Install gasket and end cover and secure with end cover screws.

EXPLODED VIEW

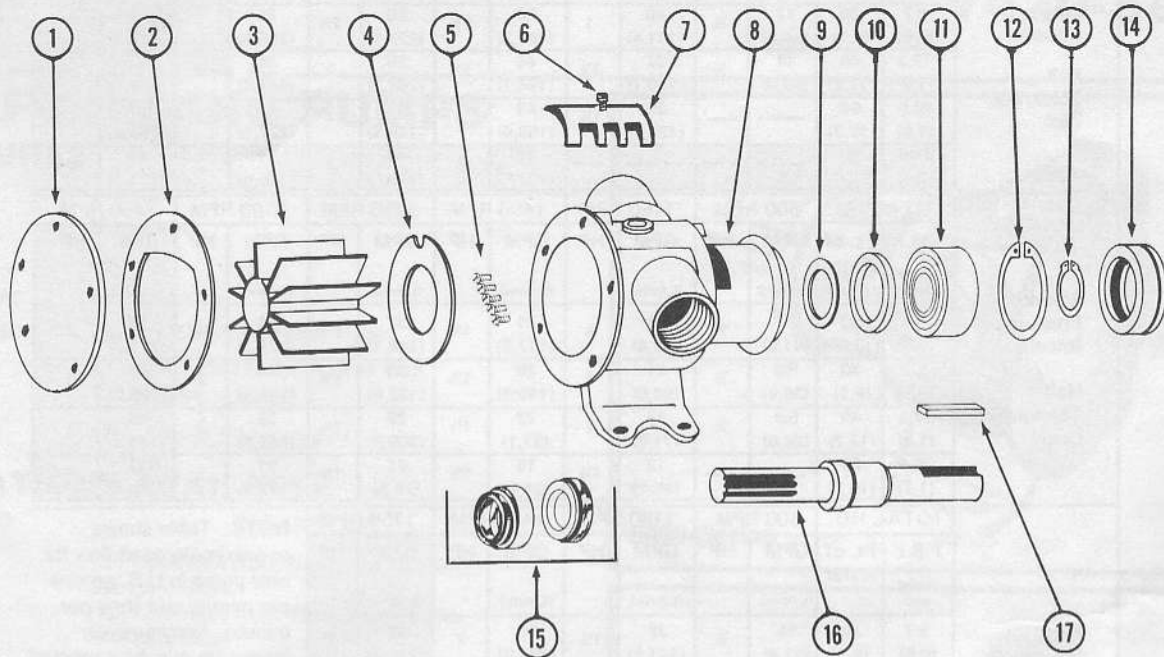

PARTS LIST

Model 6400-0004
Model 7420-0004

Key	Description	Qty. Req.	Part Number
1	End Cover	1	12062-0000
2	*Gasket for Full Thickness Cam for Half Thickness Cam	1	816-0000 2553-0000
3	*Impeller (St'd) Neoprene (Opt'l) Nitrile (Opt'l) High Pressure (Opt'l) Natural Rubber	1	17935-0001 836-0003 807-1001 836-0008
4	Wearplate	1	2574-0000
5	Screw, End Cover	5	91005-0040
6	Screw, Cam for Full Thickness Cam for Half Thickness Cam	1	91005-0040 91005-0050
7	Cam, Full Thickness Half Thickness	1	834-0001 2551-0000
8	Body, Sub Ass'y (6400) Body, Sub Ass'y (7420)	1 1	6404-0000 7424-0000
9	Slinger	1	3181-0000
10	Bearing Seal (inner)	1	817-0000
11	Ball Bearing	1	92600-0040
12	Retaining Ring (Brg. to Body)	1	18712-0000
13	Retaining Ring (Brg. to Shaft)	1	18711-0000
14	Bearing Seal** (outer)	1	818-0000
15	*Seal Assembly **	1	6407-0010
16	Shaft, Std. Length - Brass Short - S.S.	1 1	824-0000 824-1001
17	Key Service Kit Neoprene Imp. Service Kit Nitrile Imp.	1	9214-0000 90062-0001 90062-0003

* Parts Included in Service Kit

** When replacing shaft seal, the outer bearing seal is generally distorted during disassembly requiring replacement and is not included in the service kit.

HEAD CAPACITY TABLE

		TOTAL HD.		500 RPM		1160 RPM		1450 RPM		1750 RPM		2100 RPM		2450 RPM	
		P.S.I.	Ft. of Water	GPM	HP	GPM	HP	GPM	HP	GPM	HP	GPM	HP	GPM	HP
		(kg/sq cm)	(metre)	(L/min)		(L/min)		(L/min)		(L/min)		(L/min)		(L/min)	
Standard Pressure Impeller	Full Thickness Cam	4.3 (0,3)	10 (3,0)	18 (68,1)	1/2	41 (155,2)	1	51 (193,0)	1 1/2	62 (234,7)	1 1/2	72 (272,5)	3	74 (280,1)	3
		8.7 (0,6)	20 (6,1)	17 (64,4)	1/2	40 (151,4)	1	50 (189,3)	1 1/2	60 (227,1)	1 1/2	70 (265,0)	3	72 (272,5)	3
		17.3 (1,2)	40 (12,2)	14 (53,0)	1/2	37 (140,1)	1 1/2	46 (174,1)	1 1/2	55 (208,2)	2	66 (249,8)	3	71 (268,7)	3
	Standard Pressure Impeller	26.0 (1,8)	60 (18,3)	—	—	32 (121,1)	1 1/2	42 (159,0)	2	50 (189,3)	2	60 (227,1)	3	67 (253,6)	5
		34.6 (2,4)	80 (24,4)	—	—	—	—	35 (132,5)	2	44 (166,5)	2	52 (196,8)	3	60 (227,1)	5
		—	—	—	—	—	—	—	—	—	—	—	—	—	—

		TOTAL HD.		500 RPM		1160 RPM		1450 RPM		1750 RPM		2100 RPM		2450 RPM	
		P.S.I.	Ft. of Water	GPM	HP	GPM	HP	GPM	HP	GPM	HP	GPM	HP	GPM	HP
		(kg/sq cm)	(metre)	(L/min)		(L/min)		(L/min)		(L/min)		(L/min)		(L/min)	
Standard Pressure Impeller	Full Thickness Cam	4.3 (0,3)	10 (3,0)	11 (41,6)	1/2	26 (98,4)	3/4	31 (117,3)	1 1/2	37 (140,1)	1 1/2	46 (174,1)	1 1/2	56 (212,0)	2
		8.7 (0,6)	20 (6,1)	9.5 (36,0)	1/2	24 (90,8)	1	29 (109,8)	1 1/2	35 (132,5)	1 1/2	44 (166,5)	2	52 (196,8)	3
	Half Thickness Cam	17.3 (1,2)	40 (12,2)	5.5 (20,8)	1/2	19 (71,9)	1	23 (87,1)	1 1/2	29 (109,8)	1 1/2	38 (143,8)	2	45 (170,3)	3
		26.0 (1,8)	60 (18,3)	—	—	12 (45,4)	1 1/2	15 (56,8)	1 1/2	21 (79,5)	1 1/2	31 (117,3)	3	37 (140,1)	3
		—	—	—	—	—	—	—	—	—	—	—	—	—	—

		TOTAL HD.		500 RPM		1160 RPM		1450 RPM		1750 RPM	
		P.S.I.	Ft. of Water	GPM	HP	GPM	HP	GPM	HP	GPM	HP
		(kg/sq cm)	(metre)	(L/min)		(L/min)		(L/min)		(L/min)	
High Pressure Impeller	Full Thickness Cam	8.7 (0,6)	20 (6,1)	14 (53,0)	3/4	38 (143,8)	1 1/2	50 (189,3)	2	62 (234,7)	3
		21.6 (1,5)	50 (15,2)	12 (45,4)	3/4	34 (128,7)	1 1/2	44 (166,5)	3	54 (204,4)	3
	Standard Pressure Impeller	34.6 (2,4)	80 (24,4)	8 (30,3)	1	30 (113,6)	2	40 (151,4)	3	50 (189,3)	5
		47.8 (3,4)	110 (33,5)	—	—	28 (106,0)	2	36 (136,3)	3	47 (177,9)	5
		60.5 (4,3)	140 (42,7)	—	—	20 (75,7)	2	28 (106,0)	5	38 (143,8)	5

NOTE: Table shows approximate head-flow for new pump in U.S. gallons per minute and litres per minute. Progressively longer life may be expected as operating pressures and speeds are reduced. Factory Application Engineering assistance is recommended for shaded area. High starting torque motors are required. Pump starting torque in dry condition (no fluid in pump body) is 134 inch-pounds and in wet condition (fluid in pump body) is 105 inch-pounds.

DIMENSIONAL DRAWINGS † Inches (millimetres)

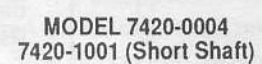
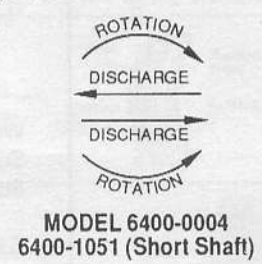
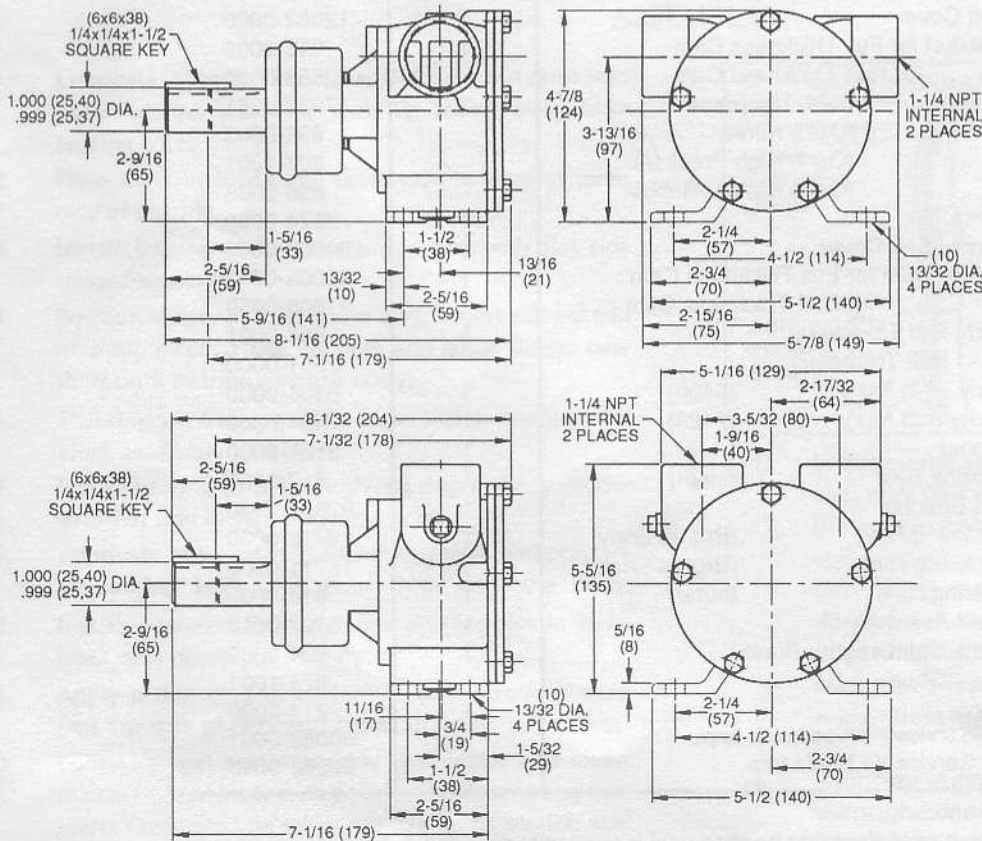

THE PRODUCTS DESCRIBED HEREIN ARE SUBJECT TO THE JABSCO ONE YEAR LIMITED WARRANTY, WHICH IS AVAILABLE FOR YOUR INSPECTION UPON REQUEST.

† Nominal dimensions for reference only.