



Models 45710-1000 45710-1020

REVERSIBLE ROTARY VANE PUMPS

FEATURES

- Body: Bronze
- Rotor: VECTRA™*
- Vanes: VECTRA™*
- Seal: Lip type, Nitrile
- Motor: Permanent Magnet Type, Intermittent Duty, Fully enclosed, Stainless Steel Shaft
- Ports: 1/2 Inch Internal Pipe Threads
1 Inch External Hose Barb
- Height: 3-3/8 Inches
- Length: 8-5/8 Inches
- Width: 4-3/4 Inches
- Weight: 5-1/2 Pounds

MODELS AVAILABLE

- 45710-1000 12 Volt DC
- 45710-1020 32 Volt DC



Do not operate with rivets removed from motor case. Explosion resulting in personal injury, death or property damage may occur. Case openings must be sealed to avoid explosion and maintain ignition protected rating.

APPLICATION

The Jabsco Reversible Rotary Vane pump is ideal for pumping oil or transferring diesel fuel. It is self-priming to about three feet and can pump against a discharge head up to twenty feet. With its integral on-off-reversing switch, it is ideal for engine oil changing. A simple valved manifold will allow it to be permanently installed to change the oil of multiple engines with a single pump. After pumping used oil out of an engine, it can be reversed to pump new oil back into engine.



Do not pump volatile liquids with a flash point below 100°F (38°C). Doing so may cause an explosion or fire resulting in injury or death.

Note: Diesel fuel has a flash point of 100° - 190°F (43° - 88°C).

INSTALLATION

The pump must be mounted in a dry location – the motor is not waterproof and must not be submerged. SELECTION OF A COOL, VENTILATED location will generally extend pump motor life. The unit can be mounted in any desired position. It is best to mount so that fluid dripping from loose port connection will not wet the motor. The pump head may be mounted at 90 degree increments on the motor to allow plumbing as needed.

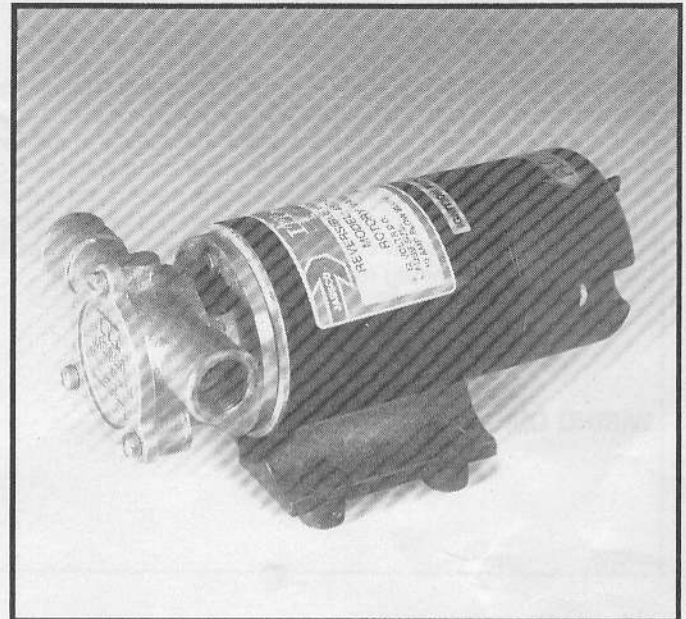

Models 45710-1000, 45710-1020

Motor with switch assembly meets USCG Electrical Standards (Title 33, Chapter I, Part 183, Subpart I) for IGNITION PROTECTION on gasoline powered vessels. SEE WARNING NOTE.

PLUMBING CONNECTIONS

Pump ports have external 1" hose barb and internal 1/2" pipe threads. Use hose that does not kink when bent and with sufficient wall thickness to prevent collapse when used on suction side of pump. Hoses should be routed so that some fluid will be retained in pump body to wet the rotor and vanes. Wetting the rotor and vanes aids in priming. Use a strainer on the intake hose if debris or solids are present in the fluid being pumped. ALL HOSES MUST HAVE AIRTIGHT CONNECTIONS TO ENABLE FAST PRIMING.

	TOTAL HEAD			CAPACITY	
	PSI	FEET	METRES	GPM	L/MIN
2.1	5	1,5	5.2	19,7	
4.3	10	3,0	5.0	18,9	
6.5	15	4,6	4.7	17,8	
8.7	20	6,1	4.3	16,3	

Table shows approximate Head-Flow for new pump.

* VECTRA™ is a registered trademark of Celanese Corporation.

ELECTRICAL CONNECTIONS



Explosion hazard. If pump is operated in an area which may contain flammable vapors, wire leads must be joined by insulated mechanical locking connectors. Loose or inadequate wire connections can spark resulting in an explosion. Property damage, injury or death may occur.

Connect black wire to negative (-) terminal of battery. The orange wire with the fuse holder should run to an overload protected switch or circuit breaker, with a wire from switch or breaker to positive (+) terminal of battery. Electrical circuit must be independent of all other accessories. Use proper wire size as determined by wire table elsewhere on this sheet. The proper fuse has been included in the fuse holder. Should this fuse blow, replace with the same size fuse after determining reason for blown fuse.

WIRING DIAGRAM

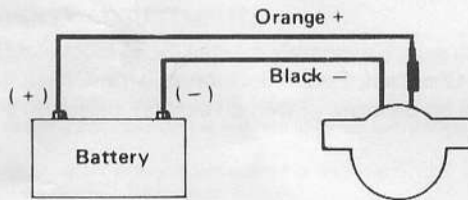

MINIMUM WIRE SIZES

CONNECTION LENGTH BETWEEN BATTERY AND MOTOR	12 V	32 V
1-10 ft. (3m)	#12	#16
11-20 ft. (6m)	# 8	#16
21-30 ft. (9m)	# 8	#16

NOTICE: To prevent motor damage, use only multi-strand copper wire in size recommended. DO NOT use ordinary lamp cord or other substitutes.

NOTICE: No warranty consideration will be given to pumps that are returned without the properly sized fuse and fuse holder supplied with the pump.

OPERATION

THE REVERSIBLE VANE PUPPY IS DESIGNED FOR INTERMITTENT DUTY. DO NOT OPERATE PUMP FOR MORE THAN 30 MINUTES CONTINUOUSLY.

Rotary Vane pumps must NOT be run dry, as the pumped liquid is the lubricant for the rotor and vanes. Observe the outlet and shut off pump as soon as liquid stops flowing.

The pump cannot run against a closed outlet such as encountered when using a garden hose type shut-off nozzle. Pressure for normal operation should not exceed 20 feet of head (8.7 PSI). Excessive pressures will cause fuse to blow.

Temperature of pumped liquid may be in the range of 45°-165° F (10°-78° C).

When pump is used for engine oil changing run engine approx. 5 minutes to heat oil (minimum oil temperature 140° F), then shut off engine just prior to oil removal.

CAUTION: Hot oil. Wear protective gloves and safety glasses when handling heated oil. Failure to do so may result in personal injury.

MODELS	VOLTAGE	AMP DRAW	FUSE SIZE
45710-1000	12 Vdc	8	15 Amp
45710-1020	32 Vdc	3	5 Amp

EXPLODED VIEW

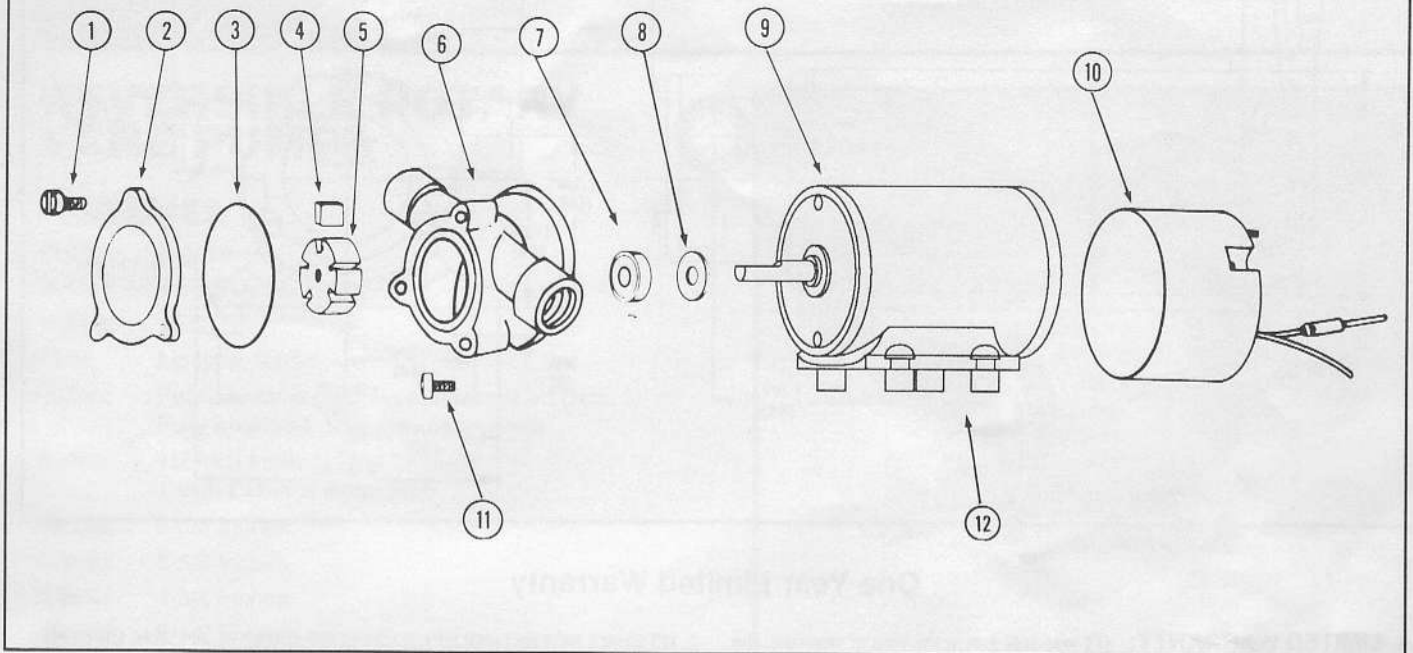

KEY	PART NUMBER	DESCRIPTION	QTY. REQ.
1	91004-0090	Screw (End Cover)	3
2	18753-0070	End Cover	1
3	18753-0071	*O-Ring	1
4	18753-0072	*Vanes (set of 5)	1
5	18753-0073	*Rotor	1
6	18753-0135	Body	1
7	1040-0000	*Seal	1
8	6342-0000	Slinger	1
9		Motor	1
	18753-0075	Model 45710-1000 12Vdc	
	18753-0076	Model 45710-1020 32 Vdc	
10	18753-0069	Switch/Housing Assy.	1
11	98019-0020	Screw (Pump to Motor)	2
12	92900-0120	†Grommet	4
	90200-0000	Service Kit	

* Parts contained in Service Kit.
 † Parts supplied with Motor.

MAINTENANCE

Check wires and connections to be sure corrosion is not adding additional resistance to the motor circuit and causing a low voltage condition at the motor. Low voltage can inhibit motor from starting and cause fuse to blow. Full voltage should be available to prevent motor damage.

If pump is to be in freezing temperatures, drain by loosening end cover screws.

DISASSEMBLY

1. Remove end cover screws, end cover and O-ring.
2. Withdraw rotor and vanes.
3. Loosen and remove two slotted hex screws, which attach body to motor.
4. Tap body lightly between ports and remove body from motor.
5. Press seal from the rotor side of the body out of the seal bore.

ASSEMBLY

1. Press seal from the motor side of the body into the seal bore with lip pointing toward the rotor bore.
2. Lubricate motor shaft and install body on motor.
3. Aligning flat in rotor with flat on motor shaft, install rotor. Install vanes in vane slots of rotor.
4. Install O-ring, end cover and end cover screws.

DIMENSIONAL DRAWING

INCHES (MILLIMETRES)

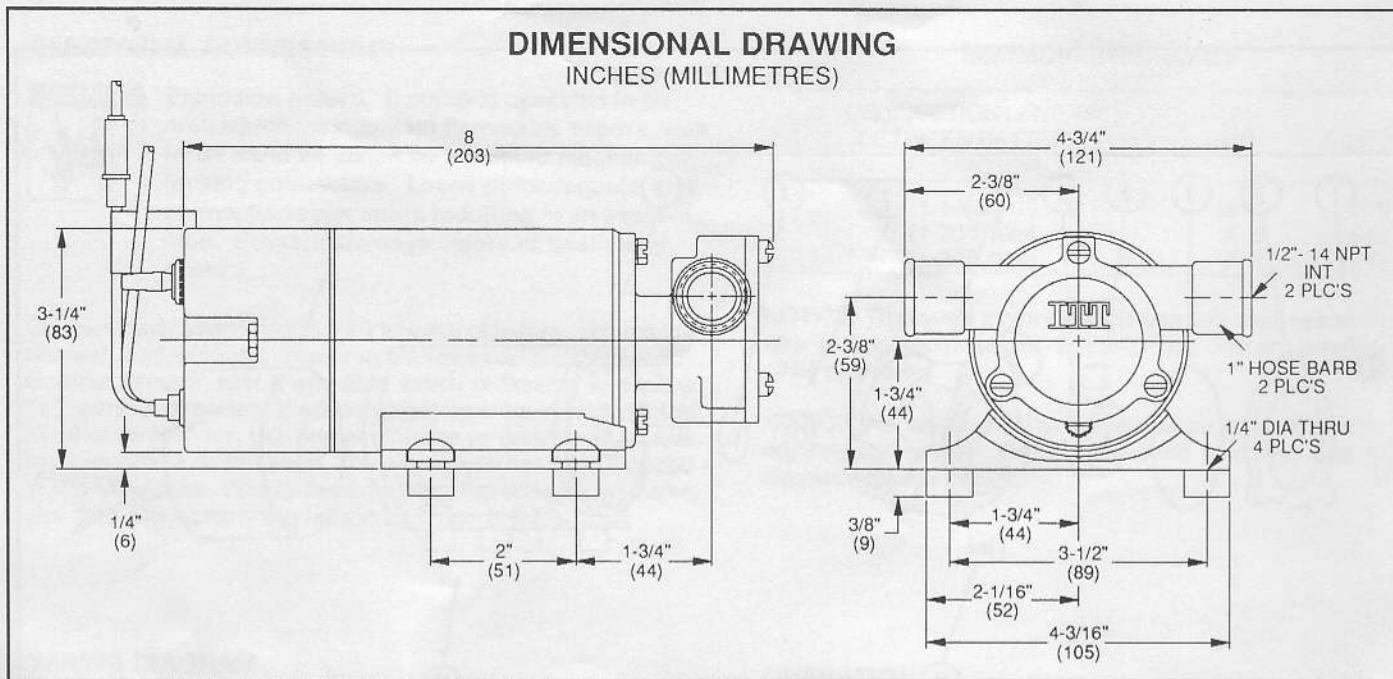

One Year Limited Warranty

A. LIMITED WARRANTY: ITT warrants that at the time of shipment, the products manufactured by ITT and sold hereunder shall be in conformity with applicable written specifications and descriptions referred to or set forth herein, free from defects in material and workmanship, merchantable, and suitable for a particular purpose, provided such is implied by State law under the circumstances of this sale.

B. WARRANTY ADJUSTMENT:

1. ITT agrees to repair or furnish a replacement for, but not to remove or install, any product or component thereof which, within one (1) year from date of purchase, shall upon test and examination by ITT prove defective within the above warranty. Receipt verifying purchase date is required to obtain adjustment.
2. Buyer shall notify ITT of any defect within this warranty no later than ninety (90) days after the defect is discovered.
3. No product will be accepted for return or replacement without the prior written authorization of ITT. Upon such authorization, and in accordance with instructions from ITT, the product will be returned to ITT, shipping charges prepaid by Buyer. Products returned to ITT will be addressed as follows:

ITT JABSCO
1485 Dale Way

Costa Mesa, California 92626-3998

Or to such alternate locations as may be designated on the product, its container, or this sheet.

Repair or replacement made under this warranty will be shipped prepaid to Buyer.

C. EXCLUSIONS FROM WARRANTY AND LIMITATION OF LIABILITY:

1. The foregoing warranty is limited solely as set forth herein and applies only for the period designated above.

2. ITT SHALL NOT BE LIABLE FOR ANY LOSS, DAMAGE, SPECIAL OR CONSEQUENTIAL DAMAGE OF ANY KIND, WHETHER BASED UPON WARRANTY, CONTRACT, NEGLIGENCE, OR STRICT LIABILITY ARISING IN CONNECTION WITH THE SALE, USE, OR REPAIR OF THE PRODUCT.

3. THE MAXIMUM LIABILITY OF ITT IN CONNECTION WITH THIS WARRANTY SHALL NOT IN ANY CASE EXCEED THE CONTRACT PRICE FOR THE PRODUCT CLAIMED TO BE DEFECTIVE OR UNSUITABLE.

4. This warranty does not extend to any product manufactured by ITT which has been subjected to misuse, neglect, accident, improper installation, or use in violation of instructions furnished by ITT.

5. This warranty does not extend to or apply to any unit which has been repaired or altered at any place other than ITT's factory, or by persons not expressly approved by ITT, nor to any unit the serial number, model number, or identification of which has been removed, defaced or changed.

6. Components manufactured by any supplier other than ITT shall bear only that warranty made by the manufacturer of that product.

7. This warranty applies to products defined as "consumer products" by the Consumer Product Warranties Act as from time to time amended.

D. CONSUMER RIGHTS: This warranty gives you specific legal rights, and you may have other rights which vary from state to state. Some states do not allow exclusion or limitation of damages.

STANDARD WARRANTY: If the products manufactured and sold hereunder are not Consumer Products, the warranty extended to Buyer shall be as set forth in subparagraphs (A), (B), and (C), EXCEPT THAT ALL EXPRESS OR IMPLIED WARRANTIES OR MERCHANTABILITY OR SUITABILITY FOR ANY PARTICULAR PURPOSE ARE EXCLUDED.

ITT Jabsco

ITT Fluid Technology Corporation

1485 Dale Way, P.O. Box 2158, Costa Mesa, CA 92628-2158

Tel: (714) 545-8251; Fax: (714) 957-0609

Bingley Road, Hoddesdon, Hertfordshire EN11 OBU England

Tel: 0992-467191; Tlx: 263251 G; Fax: 0992-467132