

3240-0001

SERVICE INSTRUCTIONS FOR DETROIT DIESEL ALLISON SERVICE KIT MODEL NUMBER 5197223

DISASSEMBLY

1. Remove end cover screws, end cover and gasket.
2. Remove impeller. To facilitate removal use water pump pliers grasping the hub, or two pair regular pliers grasping opposite blades.
3. Remove cam screw, cam and wearplate.
4. Remove seal with hooked wire. Remove seal seat and gasket.
5. Remove lock nut, lock washer, and gear.
6. Remove outboard bearing seal assembly using a two screw standard puller.
7. Remove bearing to body retaining ring.
8. Pressing on impeller end of shaft, remove shaft and bearing assembly from body.

9. Remove bearing to shaft retaining ring.
10. Supporting bearing inner race, press shaft through bearing.
11. Remove slinger from drain area.
12. Using extreme care not to mar body bore, insert screwdriver between O.D. of inner bearing seal and pump bore and pry out the seal. NOTE: Inspect all parts for wear or damage and replace where necessary.

THIS SERVICE KIT FITS THE FOLLOWING PUMP MODELS:

DDA	ITT JABSCO PRODUCTS
5187141	3240-0001
5115801	3240-0011
5187140	3240-1001
5115800	3240-1011

SERVICE INSTRUCTIONS
MODEL NUMBER 5197223

CROSS SECTION DRAWING

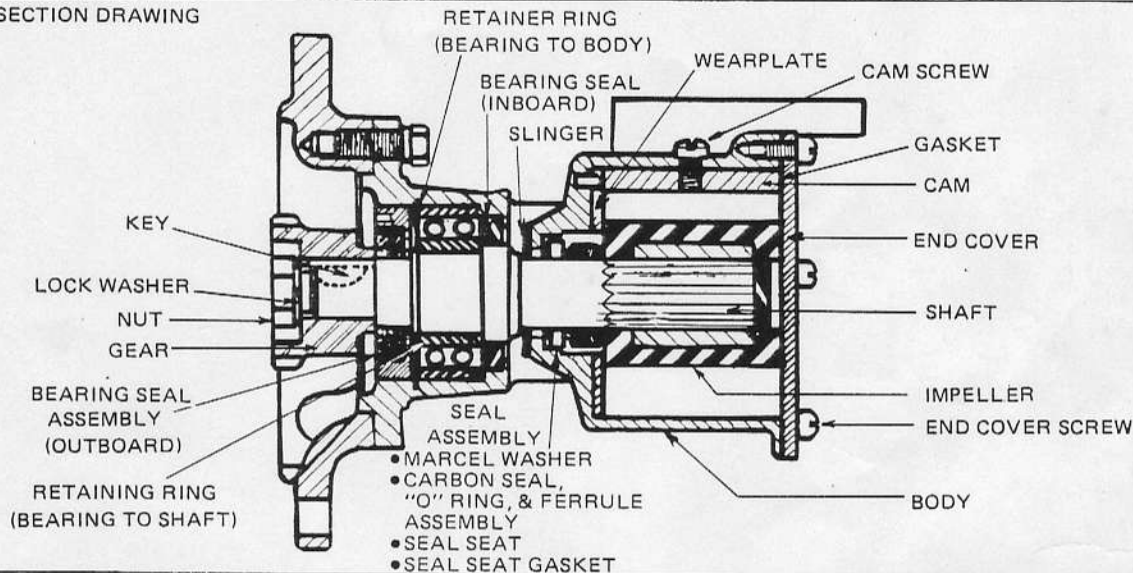

ASSEMBLY

1. Lubricate inner bearing seal with grease and press into body bearing seal bore with lip facing towards the impeller.
2. Press shaft into bearing using care to support inner race of bearing.
3. Install bearing to shaft retaining ring with flat side toward bearing.
4. Place slinger in drain area on top of seal boss.
5. Coat shaft shoulder liberally with water pump grease and insert spline end of shaft through bearing seal and slinger until bearing contacts body.
6. Pressing on bearing outer race, slowly press bearing into bore, rotating shaft during press operation to prevent damage to bearing seal lip.
7. Install bearing to body retaining ring in body groove with flat side toward bearing.
8. Press outer bearing seal assembly in body with seal lip facing away from bearing.
Install key in shaft key slot.
Install gear, lock washer and lock nut.
9. Install wearplate in body bore, aligning slot in wearplate with dowel pin in body.
12. Permatex screw threads, top side and back end of cam and install in body with cam screw.

13. Lubricate rubber boot of ceramic seal seat and boot assembly with water and insert in seal bore of body with polished surface facing outward. Care must be taken not to mar or scratch seal seat face. Installing this assembly with a slight rotary motion will insure seating the gasket firmly in the cavity.
14. Install balance of seal assembly with polished carbon seal face against ceramic seal seat. The seal assembly consists of the carbon seal ring and "O" ring which are contained within the metal ferrule. The metal ferrule has a neoprene boot over to its outside face against which the Marcel spring washer is positioned. NOTE: It is advisable to position the Marcel spring washer so that the drive points are aligned with the indentations in the boot face.
15. Lubricate impeller bore with a light coat of water pump grease and start impeller into bore with a rotary motion until splines engage, then push into bore.
16. Install gasket and end cover and secure with end cover screws.

JABSCO PRODUCTS ITT

Marine and Recreation Components Division
International Telephone and Telegraph Corporation.
1485 Dale Way, Costa Mesa, California 92626