

# SERVICE INSTRUCTIONS

## For Detroit Diesel Service Kit

### MODEL NUMBER

## 5197223, 5197224 AND 23504306

### DISASSEMBLY

1. Remove end cover screws, end cover and gasket.
2. Remove impeller. To facilitate removal, use water pump pliers grasping the hub, or two pair regular pliers grasping opposite blades.
3. Remove cam screw, cam and wearplate.
4. Remove seal with hooked wire. Remove seal seat and gasket.
5. Remove lock nut, lock washer, washer and gear.
6. Remove bearing-to-body retaining ring.
7. Pressing on impeller end of shaft, remove shaft and bearing assembly from body.
8. Supporting bearing inner race, press shaft through bearing.
9. Remove slinger from drain area.
10. Using extreme care not to mar body bore, insert screwdriver between OD of inner bearing seal and pump bore and pry out the seal. NOTE: Inspect all parts for wear or damage and replace where necessary.

THIS SERVICE KIT FITS THE FOLLOWING PUMP MODELS

DD	ITT JABSCO
5107480 . . . . .	2570-0021
5115396 . . . . .	2570-0011
5115652 . . . . .	3110-0011
5115800 . . . . .	3240-1011
5115801 . . . . .	3240-0011
5186250 . . . . .	2570-0001
5187140 . . . . .	3240-1001
5187141 . . . . .	3240-0001
5187424 . . . . .	3110-0001
23501083 . . . . .	2570-0051
23507971 . . . . .	2570-3000
23513002 . . . . .	2570-0151

### CROSS SECTION DRAWING

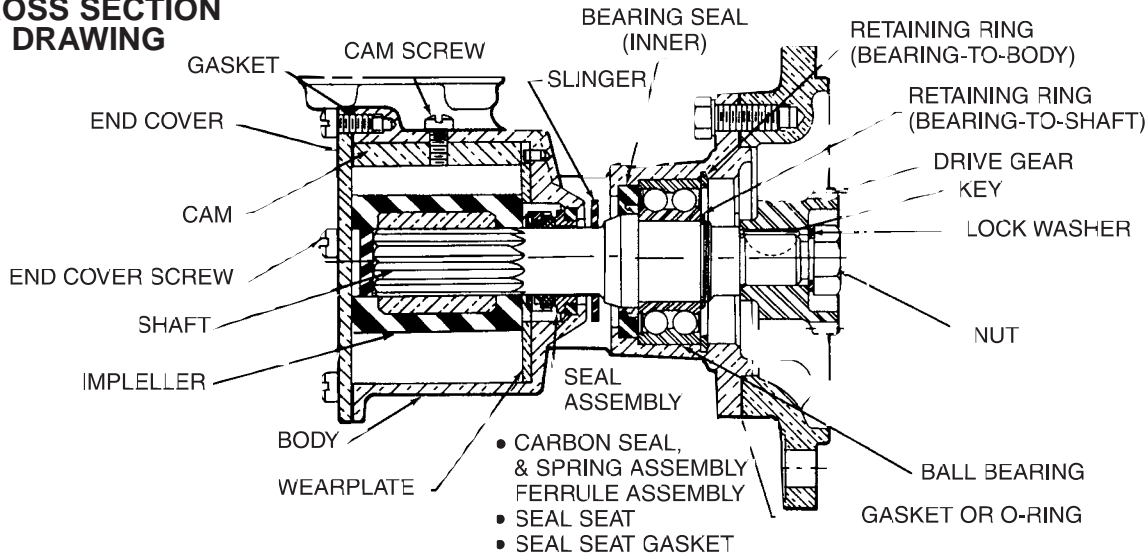

### ASSEMBLY

1. Lubricate inner bearing seal with grease and press into body bearing seal bore with lip facing towards the bearing bore.
2. Press shaft into bearing using care to support inner race of bearing and install bearing-to-shaft retaining ring with flat side against bearing.
3. Place slinger in drain area on top of seal bore.
4. Coat shaft shoulder liberally with grease and insert spline end of shaft through bearing seal and slinger until bearing contacts body.
5. Pressing on bearing outer race, slowly press bearing into bore, rotating shaft during press operation to prevent damage to bearing seal lip.
6. Install bearing-to-body retaining ring in body groove with flat side toward bearing.
7. Install key in shaft key slot.
8. Install gear, lock washer and lock nut.
9. Install wearplate, aligning slot in wearplate with dowel pin in body.
10. Apply a thin coat of sealant to cam screw threads, top side and back end of cam and install in body with cam screw.
11. Lubricate seal gasket of seal seat and gasket assembly with water and insert in seal bore of body with polished surface facing outward. Care must be taken not to mar or scratch seal seat face. Installing this assembly with a slight rotary motion will insure seating the gasket firmly in the cavity.
12. Install balance of seal assembly with polished carbon seal face against seal seat. The seal assembly consists of the carbon seal ring, tensioning spring and rubber boot.
13. Lubricate impeller bore with a light coat of grease and start impeller into bore with a rotary motion until splines engage, then push into bore.
14. Install gasket and end cover and secure with end cover screws.