



Models 30530-4XXX 30530-2XXX

SELF-PRIMING PUMPS

FEATURES

- Pump Type:** 30530-4XXX Close Coupled
30530-2XXX Pump Head
- Body:** 316 Stainless Steel
- Impeller:** Neoprene, Nitrile, Viton* or EPDM
- Shaft Seal:** Mechanical, Carbon-on-Ceramic or Tungsten Carbide; Nitrile or Viton
- Ports:** 1-1/2" NPT Internal
- Shaft:** 316 Stainless Steel
- Motor:** 230/460 Vac, 3 Phase, 60 Hz, 5 HP, 1750 RPM, TEFC, 184 TC Frame, C-Face,
- Weight:** 30530-4XXX 93.5 lb (42,5 kg) Approx.
30530-2XXX 30.0 lb (13,6 kg) Approx.

	<p>WARNING</p> <p>Explosion hazard. Motor can spark. Explosion & death can occur. Do not use where flammable vapors are present.</p>
--	---

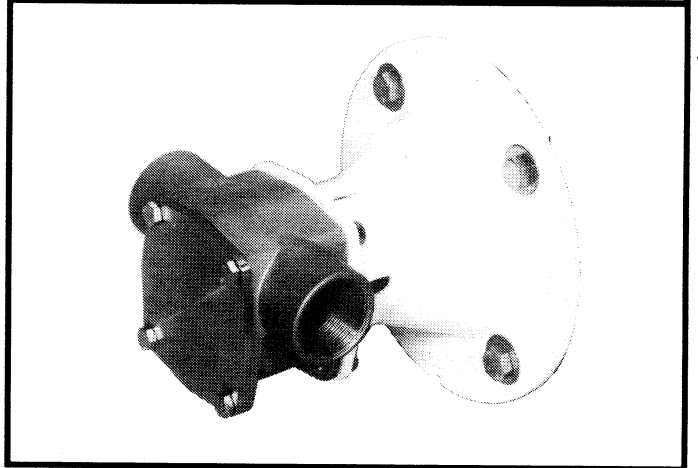
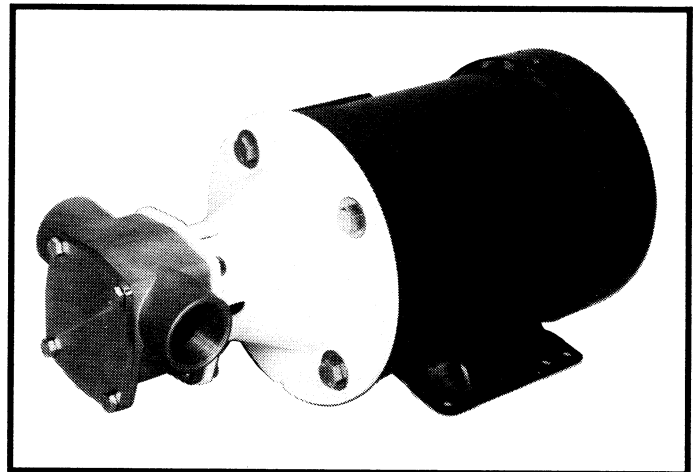

Models 30530-4XXX, 30530-2XXX

APPLICATIONS

INDUSTRIAL: Circulating and transferring, velocity-mixing, pumping machine tool coolants, spill return, sump drainage, chemicals, pharmaceuticals, soap, liquors, ink, dyes, alcohol, dilute acids, tanning liquors, glycerine, brine, etc.

PHARMACEUTICAL: Processing lab solutions, medicines, lotions and preparations. Filtering pharmaceutical solutions. Filling line supply pump.

PAPER PROCESSING: Transferring and applying starches, sizes, etc. Circulating and processing wood pulp slurries.

FOOD, BEVERAGE & DAIRY: Transfer brines, vinegar, syrups during processing, liquids containing solids in suspension such as chopped tomatoes, nuts, etc. Removal of distillery wort and brewery slop. Processing viscous materials such as peanut butter, mayonnaise, ketchup, honey, etc. (low speed). Pumping whiskey, wine, rums, juices and ciders.

AGRICULTURAL: Transferring liquid fertilizers, herbicides and pesticides.

	<p>WARNING</p> <p>Explosion hazard. Do not pump gasoline, solvents, thinners or other flammable liquids. To do so can cause an explosion resulting in injury or death.</p>
--	---

VARIATIONS AVAILABLE

MODEL	DESCRIPTION
30530-4001 30530-2001	Standard Pressure, Neoprene Impeller, Carbon Seal
30530-4003 30530-2003	Standard Pressure, Nitrile Impeller, Carbon Seal
30530-4004 30530-2004	Standard Pressure, Viton Impeller, Carbon Seal
30530-4101 30530-2101	Standard Pressure, Neoprene Impeller, Tungsten Carbide Seal
30530-4103 30530-2103	Standard Pressure, Nitrile Impeller, Tungsten Carbide Seal
30530-4104 30530-2104	Standard Pressure, Viton Impeller, Tungsten Carbide Seal

* Viton is a trademark of E.I. Du Pont de Nemours and Company.

OPERATING INSTRUCTIONS

- 1. INSTALLATION** – Pump may be mounted in any position. The rotation of the pump shaft determines the location of the pump's intake and discharge ports. Refer to dimensional drawing. Pump is normally assembled at factory for clockwise rotation (looking at end cover). If counter clockwise rotation is desired, follow steps 1 and 2 of disassembly and step 7 of assembly instructions to change direction of impeller blade deflection under cam.
- 2. MOTOR SELECTION** – Pump head is designed to fit a 184 TC Frame NEMA C-face motor. Motor should be rated 5 horsepower at 1750 RPM with a service factor of one. Due to high bearing loads, motor should be ball bearing equipped with the front bearing locked against axial movement. Motor should be three phase and foot mounted.
- 3. SPEEDS** – 100 RPM to the maximum shown in the performance curves. For longer pump life, operate at lowest possible speeds. Lower speeds are required for viscous liquids. Consult the factory for proper speeds and horsepower requirements.
- 4. SELF-PRIMING** – Primes at low or high speeds. For vertical dry suction lift of 10 feet, a minimum of 860 RPM is required. Pump will produce suction lift up to 22 feet when wet.
BE SURE SUCTION LINES ARE AIRTIGHT OR PUMP WILL NOT SELF-PRIME.
- 5. DISCHARGE** – When transferring liquids further than 25 feet, use one size larger discharge line than discharge port size.
- 6. RUNNING DRY** – Unit depends on liquid pumped for lubrication. **DO NOT RUN DRY** for more than 30 seconds. Lack of liquid will damage the impeller.
- 7. CHEMICAL COMPATIBILITY** – Consult the Chemical Resistance Guide in the JABSCO Industrial Pump Catalog (available upon request from ITT Jabsco) or factory for proper body materials and impeller compounds. If corrosive fluids are handled, pump life will be prolonged if pump is flushed with a neutralizing solution after each use or after each work day. A Tungsten Carbide Seal variation is available for pumping liquids that contain abrasives or are highly corrosive.
- 8. PRESSURES** – Consult Performance Curve for maximum recommended pressure for pumps in continuous operation. If pressures exceed those shown, consult the factory.
- 9. TEMPERATURES** – The operating temperature limits of the pump depend on the impeller compound. The following ranges apply: Neoprene - 45° to 180° F (7° to 82° C), Nitrile - 50° to 180° F (10° to 82° C), Viton - 60° to 180° F (15° to 82° C), EPDM - 45° to 185° F (7° to 85° C).
- 10. IMPELLER TORQUE** – The torque required to initiate rotation of a new impeller in a dry pump body is:
Standard Pressure Impeller (14346-Series):
Forward = 14.5 pounds force - feet
Reverse = 43.0 pounds force - feet
These values may vary slightly due to impeller compounding, blade set, and body material of construction. Consult factory for more information.
- 11. SPARE PARTS** – To avoid costly shutdowns, keep a spare JABSCO impeller, seal and O-ring set on hand.

SERVICE INSTRUCTIONS

DISASSEMBLY

1. Remove the four end cover screws. Remove end cover and O-ring.
2. Remove the four screws holding the body to the adapter flange. Slide body, complete with impeller, from adapter and shaft.
3. Remove mechanical seal by inserting two screwdrivers behind seal collar, and gently lever collar and seal assembly forward on shaft. Use extreme care not to mar shaft surface. Remove seal seat and rubber cup.
4. Remove the four screws holding the adapter to the motor and remove the adapter.
5. The stub shaft is held in place with set screws and Loctite* RC/680 retaining compound. Extreme care must be taken not to damage the motor shaft and bearings when removing the stub shaft. Heat shaft joint area to facilitate disassembly of set screws and stub shaft from motor shaft. **DO NOT EXCEED 300°F** when heating joint area. Once joint area has been heated, remove set screws and slide stub shaft from motor shaft.

ASSEMBLY

1. Liberally apply Loctite RC/680 retaining compound to the motor shaft and slide the stub shaft on, positioning the base of the stub shaft 0.37" from the bolt mounting surface of motor. For clarification, refer to Figure 1 below. Apply Loctite to the four set screws and torque to 85 - 90 in. lbs. Wipe off excess Loctite.
2. Replace the adapter on the motor and tighten the four mounting screws to 40 ft. lbs.
3. Replace mechanical seal by sliding spacer onto shaft up to locating shoulder, then smear shaft with light lubricating oil. Push on seal gently until it engages with spacer. Fit rubber cup and seal seat into rear of pump body.
4. Insert impeller in pump body, fit O-ring in each end of the pump body.
5. Slide body assembly over shaft. Fit body to adapter screws. Torque screws to 10 in. lbs.
NOTE: A gap should be maintained between bearing housing and body.
DO NOT overtighten screws.
6. Fit end cover and end cover screws. Torque screws to 10 in. lbs.
7. Changing Pump Rotation (looking at end cover):
 - a. Clockwise Rotation: Insert impeller into pump body with blades bending counterclockwise.
 - b. Counterclockwise Rotation: Insert impeller into pump body with blades bending clockwise.

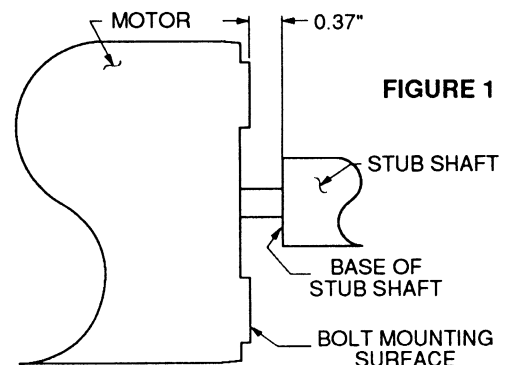

PARTS LIST

KEY	DESCRIPTION	QTY. REQ.	MODEL 30530-4XXX PART NO.	QTY. REQ.	MODEL 30530-2XXX PART NO.
1	Adapter	1	18753-0217	1	18753-0217
2	Body	1	18753-0191	1	18753-0191
3	End Cover	1	18753-0197	1	18753-0197
4	Wearplate	1	18753-0201	1	18753-0201
5	Shaft	1	18753-0213	1	18753-0213
6	Impeller: Standard Pressure - Neoprene Standard Pressure - Nitrile Standard Pressure - Viton Standard Pressure - EPDM	1	14346-0005 14346-0003 14346-0004 14346-0002	1	14346-0005 14346-0003 14346-0004 14346-0002
7	Motor, 5 HP, 230/460Vac, 3Ph, 60Hz, TEFC, C-Face, 184 TC Frame	1	18753-0220	-	-
8	Spacer:	1	18753-0228	1	18753-0228
9	Seal Seat: Carbon - Nitrile Carbon - Viton Tungsten Carbide - Nitrile Tungsten Carbide - Viton	1	18753-0237 18753-0238 18753-0239 18753-0240	1	18753-0237 18753-0238 18753-0239 18753-0240
10	Seal Mech.: Carbon - Nitrile Carbon - Viton Tungsten Carbide - Nitrile Tungsten Carbide - Viton	1	18753-0249 18753-0250 18753-0251 18753-0252	1	18753-0249 18753-0250 18753-0251 18753-0252
11	O-Ring: Nitrile Viton	2	18753-0265 18753-0266	2	18753-0265 18753-0266
12	Screw Kit: consists of Bolts, Hex Hd. 1/2-13 x 1" (4) Screws, Hex Hd. M8 x 20mm (4) Screws, Pan Hd. M8 x 14mm (4) Set Screw, Cup Pt. 1/4-20 x 1/4 (4) Washers, Flat 1/2 (4) Washers, Flat M8 (4)	1	18753-0286	1	18753-0286

EXPLODED VIEW

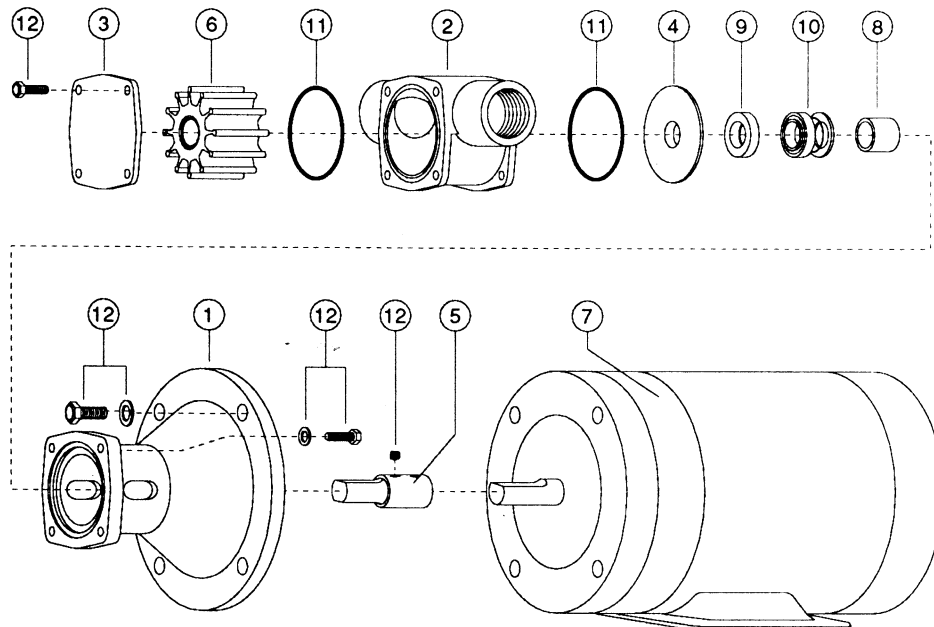

DIMENSIONAL DRAWINGS INCHES (Millimetres)

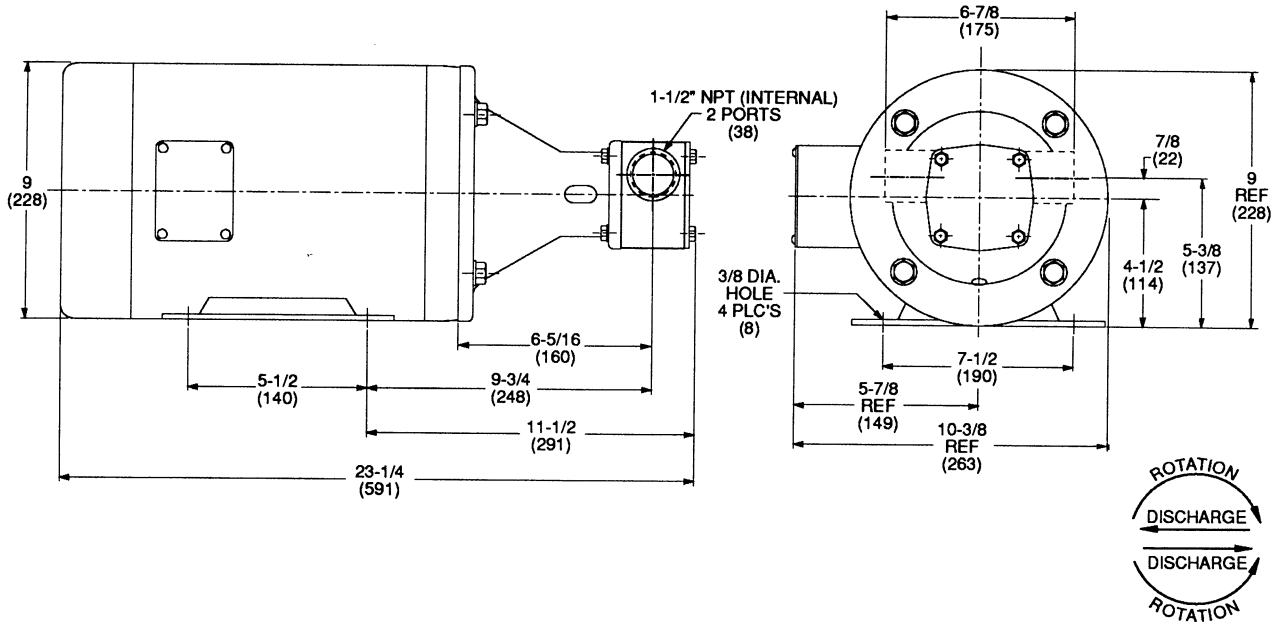

PERFORMANCE CURVES

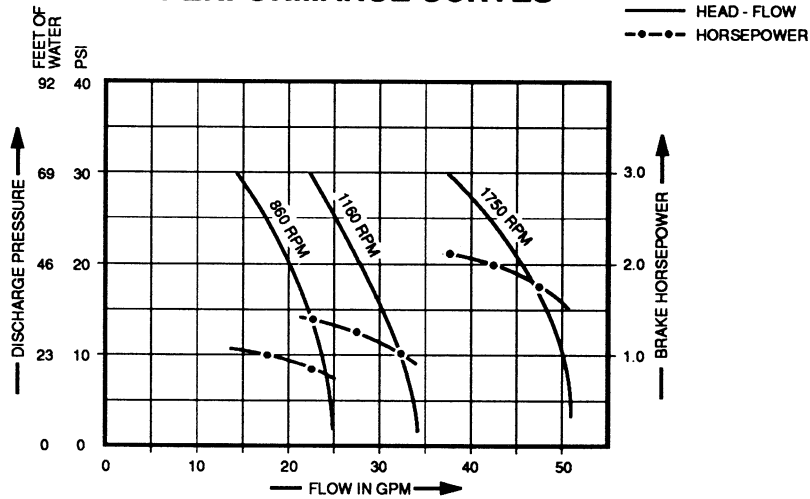

NOTE: Curve shows approximate head-flow for new pumps with neoprene impeller pumping water. Capacities should be reduced approximately 10% for nitrile, viton and EPDM impellers.

Consult factory for specific performance information.

ITT Jabsco

A Unit of ITT Fluid Technology Corporation



THE PRODUCTS DESCRIBED HEREIN ARE SUBJECT TO THE JABSCO ONE YEAR LIMITED WARRANTY, WHICH IS AVAILABLE FOR YOUR INSPECTION UPON REQUEST.

U.S.A.
ITT Jabsco
1485 Dale Way, P.O. Box 2158
Costa Mesa, CA 92628-2158
Tel: (714) 545-8251
Fax: (714) 957-0609

UNITED KINGDOM
ITT Jabsco
Bingley Road, Hoddesdon
Hertfordshire EN11 0BU
Tel: +44 (0) 1992 450145
Fax: +44 (0) 1992 467132

CANADA
ITT Fluid Products
55 Royal Road
Guelph, Ontario N1H 1T1
Tel: (519) 821-1900
Fax: (519) 821-2569

JAPAN
NHK Jabsco Company Ltd.
3-21-10, Shin-Yokohama
Kohoku-Ku, Yokohama, 222
Tel: 045-4758906
Fax: 045-475-8908

GERMANY
MINTEC GmbH
Postfach 1703/Oststrasse 28
D-22807 Norderstedt
Tel: +49-40-53 53 73 -0
Fax: +49-40-53 53 73 -11