

Jabco 28440 : 28480 SERIES

EXPLODED VIEW

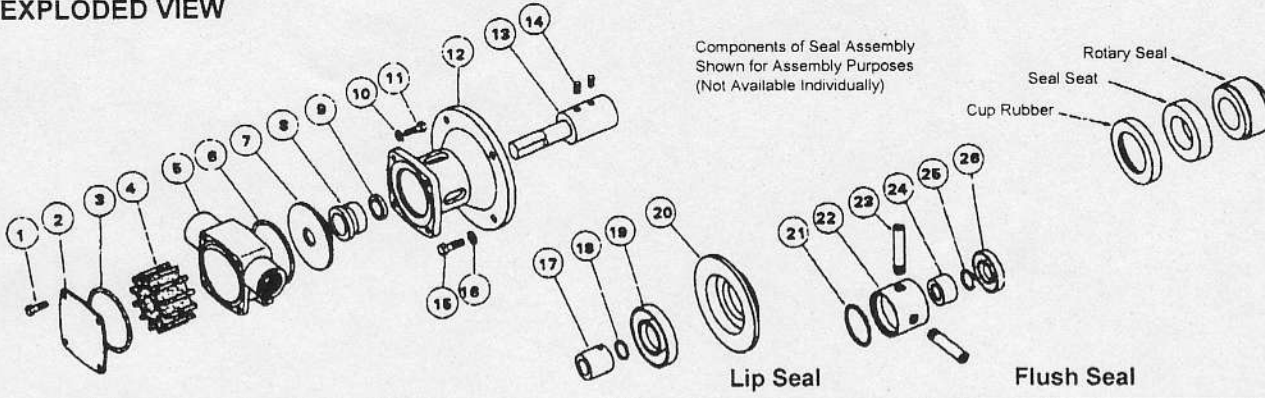

Components of Seal Assembly
Shown for Assembly Purposes
(Not Available Individually)

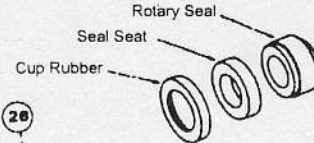

Lip Seal

Flush Seal

PARTS LIST			STANDARD PRESSURE IMPELLER			HIGH PRESSURE IMPELLER		
			Neoprene Elast: 28440-2115	Nitrile Elast: 28440-2113	Viton Elast: 28440-2114	Neoprene Elast: 28480-2125	Nitrile Elast: 28480-2123	Viton Elast: 28480-2124
Key	Description	Qty						
1	Screw	4	X3001-205F	X3001-205F	X3001-205F	X3001-205F	X3001-205F	X3001-205F
2	Endcover	1	28405-0010	28405-0010	28405-0010	28405-0010	28405-0010	28405-0010
3	"O" Ring*	1	X4020-399A	X4020-399A	X4020-399B	X4020-399A	X4020-399A	X4020-399B
4	Impeller*	1	14346-0005B	14346-0013B	14346-0014B	8983-0005B	8983-0023B	8983-0024B
5	Body	1	28434-2000	28434-2000	28434-2000	28434-2000	28434-2000	28434-2000
6	"O" Ring*	1	X4020-399A	X4020-399A	X4020-399B	X4020-399A	X4020-399A	X4020-399B
7	Wearplate(1)	1	28436-0000	28436-0000	28436-0000	28436-0000	28436-0000	28436-0000
8	Seal Assembly(1)*	1	28431-0103B	28431-0103B	28431-0104B	28431-0103B	28431-0103B	28431-0104B
9	Seal Spacer(1,2,3)	1	28417-0000	28417-0000	28417-0000	28417-0000	28417-0000	28417-0000
10	Washer	4	X3080-101F	X3080-101F	X3080-101F	X3080-101F	X3080-101F	X3080-101F
11	Screw	4	X3001-209F	X3001-209F	X3001-209F	X3001-209F	X3001-209F	X3001-209F
12	Adaptor	1	28423-0000	28423-0000	28423-0000	28423-0003	28423-0003	28423-0003
13	Shaft Extension	1	28427-0001	28427-0001	28427-0001	Requires Integral Motor Shaft. See Drawing For Details		
14	Set Screw	2	X3009-203A	X3009-203A	X3009-203A			
15	Screw	4	X3001-209F	X3001-209F	X3001-209F	X3001-209F	X3001-209F	X3001-209F
16	Washer	4	X3080-101F	X3080-101F	X3080-101F	X3080-101F	X3080-101F	X3080-101F
Service Kit Contains*			SK378-0115	SK378-0113	SK378-0114	SK378-0125	SK378-0123	SK378-0124
Other Seal Options								
Model No. With H/F Seal	28440-2215	28440-2213	28440-2214	28440-2225	28440-2223	28440-2224		
Model No. With Lip Seal	28440-2415	28440-2413	Not Available	28440-2425	28440-2423	Not Available		
Model No. With H/F Seal Flushed	28440-2715	28440-2713	28440-2714	28440-2725	28440-2723	28440-2724		
Model No. With Standard Seal/Flushed	28440-2915	28440-2913	28440-2914	28440-2925	28440-2923	28440-2924		
Parts For Appropriate Seal Conversion								
8	H/F Seal Assembly	1	28431-0203B	28431-0203B	28431-0204B	28431-0203B	28431-0203B	28431-0204B
Lip Seal Kit No. & Contains			28431-0403B	28331-0403B	Not Available	Not Available	Not Available	Not Available
17	Seal Spacer	1	28465-0011	28465-0011	Not Available	Not Available	Not Available	Not Available
18	"O" Ring	1	X4020-227A	X4020-227A	Not Available	Not Available	Not Available	Not Available
19	Seal	1	SP2701-0915	SP2701-0915	Not Available	Not Available	Not Available	Not Available
20	Wearplate	1	28466-0000	28466-0000	Not Available	Not Available	Not Available	Not Available
Flush Seal Kit No. & Contains			28432-0000B	28432-0000B	28432-0000B	Not Available	Not Available	Not Available
21	"O" Ring	1	X4020-261A	X4020-261A	X4020-261A	Not Available	Not Available	Not Available
22	Seal Housing	1	28412-0000	28412-0000	28412-0000	Not Available	Not Available	Not Available
23	Tube	2	21844	21844	21844	Not Available	Not Available	Not Available
24	Seal Spacer(2)	1	28417-0001	28417-0001	28417-0001	Not Available	Not Available	Not Available
25	"O" Ring(2)	1	X4020-227A	X4020-227A	X4020-227A	Not Available	Not Available	Not Available
26	Seal	1	SP2701-0915	SP2701-0915	SP2701-0915	Not Available	Not Available	Not Available
(1) Key 7, 8 & 9 Not Required For Lip Seal Models: (2) Key 9, 24 & 25 Not Required For one piece Shaft.								
(3) Key 9 Required For High Pressure Impeller Models								

SERVICE INSTRUCTIONS

Dis-Assembly

- Remove screws (1), endcover and "O" rings (3). Remove screws (11) and slide off body complete with body. Push out impeller and "O" ring (6) from body.
- Remove wearplate (7) and prise out seal seat and cup rubber.
- Gently lever the spacer (9) (if fitted) and rotary seal off the shaft. Removal of the following parts is not necessary for normal servicing. However, if required proceed as follows:-
- Remove screws (15) and washers (16) and slide off adaptor (12). For motors with integral stainless steel shaft step 5 is not applicable.
- Loosen set screws (14) then applying heat and leverage slide off shaft extension. Do not heat damage motor seal and bearing. Do not tamper with motor.

Pumps With Lip Seal:- Push out lip seal (19) from wearplate (20) and loosen set screws to remove spacer (17) and prise out "O" ring (18) from spacer.

Pumps With Flush Seal:- After pulling out rotary seal, unscrew tubes (23) and pull out seal housing (22). If fitted:- Remove seal spacer and prise out "O" ring (25). Remove "O" ring (21) and lip seal (26) from seal housing.

Assembly

- To assemble shaft extension (Not applicable to H.P. pumps):- Support motor shaft (from end). Align set screws (14) with the shaft keyway and press on the shoulder of the shaft extension. Tighten set screws (14).
- Slide seal spacer (9) (if fitted), on shaft then smear shaft with oil and push rotary seal gently until it touches the spacer or shaft shoulder.
- Fit adaptor (12) to motor face with screws (15) and washers (16).
- Fit cup rubber and seal seat into wearplate and slide into position over shaft.
- Fit impeller into lubricated body with a twisting motion in the same direction as motor. Fit "O" ring (6) into body and slide into position over shaft.
- Align wearplate and body with adaptor and secure with screws (11) and washers (10). Do not overtighten, a gap between adaptor and body is normal. These screws and endcover screws should be tightened to a torque of 6.8 Nm.
- Fit "O" ring (3) into body and place endcover over body and secure with screws (1).

Pumps With Lip Seal:- Fit "O" ring (18) into seal spacer (17) and smear spacer and shaft with lubricating oil. Slide spacer over shaft and secure with set screws to dimension shown. Press lip seal (19) into wearplate (20) and slide into position over shaft, then follow on from step 5 above.

Pumps With Flush Seal:- (shafts with seal spacer (24)). Fit "O" ring (25) under seal spacer and smear both spacer and shaft with oil and slide spacer up to shaft shoulder. Press lip seal (26) into seal housing (22) and slide into position. Fit tubes (23) sealing with PTFE tape. Rotary seal and "O" ring (21) can now be fitted. The follow step 5 above.

Inspect all parts for wear or damage and replace if necessary.

INSTALLATION DRAWING

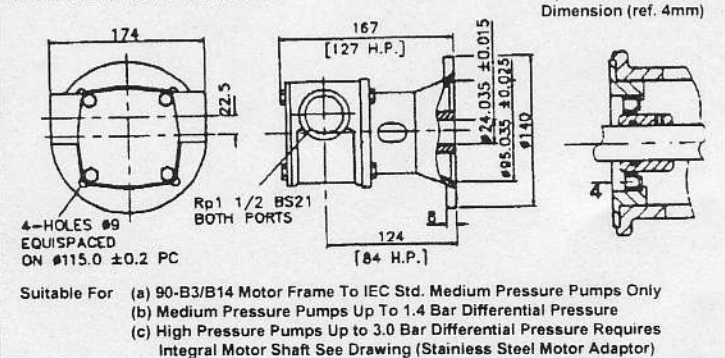

Lip Seal Spacer Position
Dimension (ref. 4mm)

