

Jabsco 28260 SERIES

EXPLODED VIEW

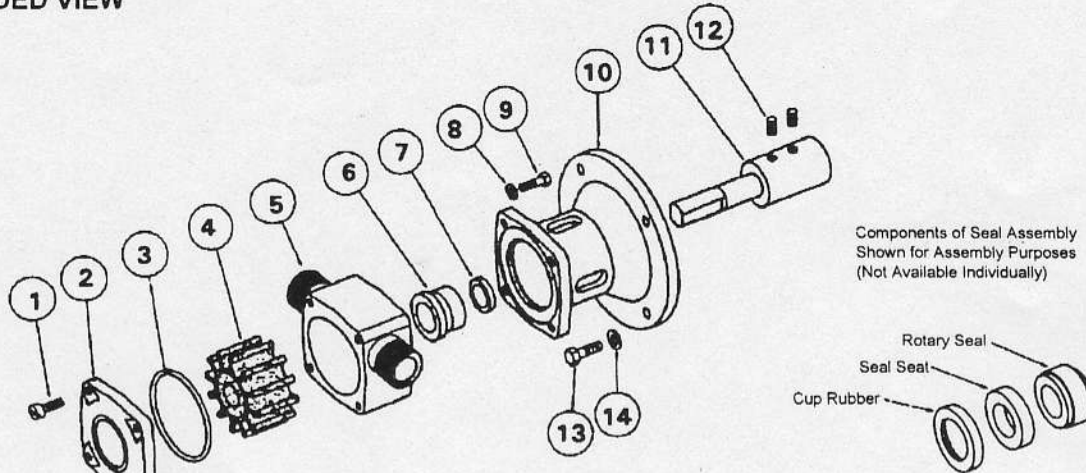

Components of Seal Assembly
Shown for Assembly Purposes
(Not Available Individually)

PARTS LIST			STANDARD PRESSURE IMPELLER			HIGH PRESSURE IMPELLER		
Key	Description	Qty	Neoprene Elast: 28260-2101	Nitrile Elast: 28260-2103	Viton Elast: 28260-2104	Neoprene Elast: 28260-2121	Nitrile Elast: 28260-2123	Viton Elast: 28260-2124
1	Screw	4	X3002-153F	X3002-153F	X3002-153F	X3002-153F	X3002-153F	X3002-153F
2	Endcover	1	28255-0000	28255-0000	28255-0000	28255-0000	28255-0000	28255-0000
3	"O" Ring*	1	X4020-259A	X4020-259A	X4020-259B	X4020-259A	X4020-259A	X4020-259B
4	Impeller*	1	14281-0001B	14281-0003B	14281-0004B	8980-0021B	8980-0023B	8980-0024B
5	Body	1	28254-2000	28254-2000	28254-2000	28254-2000	28254-2000	28254-2000
6	Seal Assembly*	1	28231-0103B	28231-0103B	28231-0104B	28231-0103B	28231-0103B	28231-0104B
7	Spacer	1	28219-0002	28219-0002	28219-0002	28219-0002	28219-0002	28219-0002
8	Washer	4	X3080-081F	X3080-081F	X3080-081F	X3080-081F	X3080-081F	X3080-081F
9	Screw	4	X3001-153F	X3001-153F	X3001-153F	X3001-153F	X3001-153F	X3001-153F
10	Adaptor	1	28223-0000	28223-0000	28223-0000	28223-0000	28223-0000	28223-0000
11	Shaft Ext.	1	28267-0000	28267-0000	28267-0000	28267-0000	28267-0000	28267-0000
12	Set Screw	2	X3009-176A	X3009-176A	X3009-176A	X3009-176A	X3009-176A	X3009-176A
13	Screw	4	X3001-180F	X3001-180F	X3001-180F	X3001-180F	X3001-180F	X3001-180F
14	Washer	4	X3080-091F	X3080-091F	X3080-091F	X3080-091F	X3080-091F	X3080-091F
Service Kit Contains*			SK376-0101	SK376-0103	SK376-0104	SK376-0121	SK376-0123	SK376-0124
OTHER SEAL OPTIONS								
Model No. With H/F Seal	22860-2201	22860-2203	22860-2204	22860-2221	22860-2223	22860-2224		
PARTS FOR APPROPRIATE SEAL CONVERSION								
6 Seal H/F	1	28231-0203B	28231-0203B	28231-0204B	28231-0203B	28231-0203B	28231-0204B	
Optional 23470-0065B High Temperature Impeller Available								

SERVICE INSTRUCTIONS

Dis-Assembly

1. Remove screws (1), endcover and "O" ring. Remove screws (9) and slide off body complete with impeller. Remove seal seat and cup rubber and push out impeller from body.
2. Gently lever the spacer (7) and seal (6), off the shaft.

Removal of the following parts is not necessary for normal servicing. However if required then as follows:-

3. Remove screws (13) and washers (14) and slide off adaptor (10).
4. Loosen set screws (12), then applying heat and leverage slide off shaft extension. Do not heat damage epoxy coating of shaft, motor seal and bearing.

Do Not Tamper With Motor.

Assembly

1. To assemble shaft extension:- Support motor shaft (fan end). Align set screws (12) with the shaft keyway and press on the shoulder of the shaft extension. Tighten set screws (12).
2. Slide seal spacer on shaft then smear shaft with oil and push rotary seal gently until it touches the spacer.
3. Fit adaptor to motor with screws (13) and washers (14).
4. Fit impeller into lubricated body with a twisting motion in the same rotation as motor. Fit cup rubber and seal seat into body.
5. Slide this assembly over shaft and fit with screws (9) and washer (8) to adaptor.
6. Fit "O" ring into endcover and secure with screws (1) onto body.

INSTALLATION DRAWING

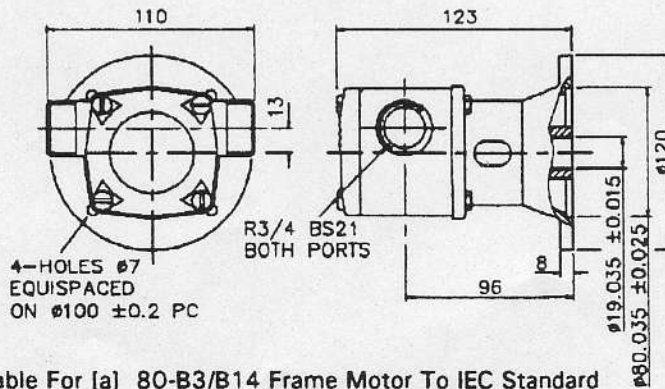

Suitable For [a] 80-B3/B14 Frame Motor To IEC Standard
[b] Up To 2.5 Bar Differential Pressure

Inspect all parts for wear or damage and replace if necessary.