

Jabsco 28240 SERIES

EXPLODED VIEW

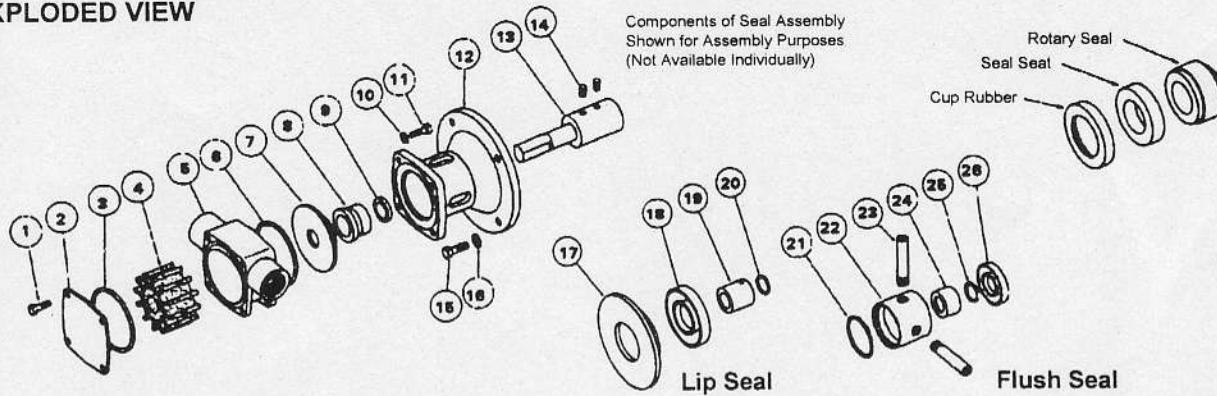

Components of Seal Assembly
Shown for Assembly Purposes
(Not Available Individually)

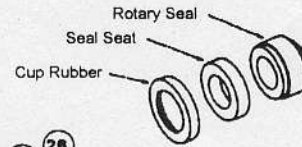

Lip Seal

Flush Seal

PARTS LIST			STANDARD PRESSURE IMPELLER			HIGH PRESSURE IMPELLER		
			Neoprene Elast: 28240-2101	Nitrile Elast: 28240-2103	Viton Elast: 28240-2104	Neoprene Elast: 28240-2121	Nitrile Elast: 28240-2123	Viton Elast: 28240-2124
Key	Description	Qty						
1	Screw	4	X3001-147F	X3001-147F	X3001-147F	X3001-147F	X3001-147F	X3001-147F
2	Endcover	1	28205-0010	28205-0010	28205-0010	28205-0010	28205-0010	28205-0010
3	"O" Ring	1	X4020-259A	X4020-259A	X4020-259B	X4020-259A	X4020-259A	X4020-259B
4	Impeller	1	14281-0001B	14281-0003B	14281-0004B	8980-0021B	8980-0023B	8980-0024B
5	Body	1	28234-2000	28234-2000	28234-2000	28234-2000	28234-2000	28234-2000
6	"O" Ring	1	X4020-259A	X4020-259A	X4020-259B	X4020-259A	X4020-259A	X4020-259B
7	Wearplate(1)	1	28236-0000	28236-0000	28236-0000	28236-0000	28236-0000	28236-0000
8	Seal Assy(1)	1	28231-0103B	28231-0103B	28231-0104B	28231-0103B	28231-0103B	28231-0104B
9	Seal Spacer(1,2)	1	28219-0000	28219-0000	28219-0000	28219-0000	28219-0000	28219-0000
10	Washer	4	X3080-081F	X3080-081F	X3080-081F	X3080-081F	X3080-081F	X3080-081F
11	Screw	4	X3001-153F	X3001-153F	X3001-153F	X3001-153F	X3001-153F	X3001-153F
12	Adaptor	1	28223-0000	28223-0000	28223-0000	28223-0000	28223-0000	28223-0000
13	Shaft Extension	1	28227-0001	28227-0001	28227-0001	28227-0001	28227-0001	28227-0001
14	Set Screw	2	X3009-176A	X3009-176A	X3009-176A	X3009-176A	X3009-176A	X3009-176A
15	Screw	4	X3001-180F	X3001-180F	X3001-180F	X3001-180F	X3001-180F	X3001-180F
16	Washer	4	X3080-091F	X3080-091F	X3080-091F	X3080-091F	X3080-091F	X3080-091F
Service Kit Contains*			SK376-0101	SK376-0103	SK376-0104	SK376-0121	SK376-0123	SK376-0124
Other Seal Options								
Model No. With H/F Seal			28240-2201	28240-2203	28240-2204	28240-2221	28240-2223	28240-2224
Model No. With Lip Seal			28240-2401	28240-2403	Not Available	28240-2421	28240-2423	Not Available
Model no. With H/F Seal Flushed			28240-2701	28240-2703	28240-2704	28240-2721	28240-2723	28240-2724
Model No. With Standard Seal Flushed			28240-2901	28240-2903	28240-2904	28240-2921	28240-2923	28240-2924
Parts For Appropriate Seal Conversion								
8	H/F Seal Assembly	1	28231-0203B	28231-0203B	28231-0204B	28231-0203B	28231-0203B	28231-0204B
Lip Seal Kit No. & Contains			28231-0403B	28231-0403B	Not Available	28231-0403B	28231-0403B	Not Available
17	Wearplate	1	28266-0000	28266-0000	Not Available	28266-0000	28266-0000	Not Available
18	Seal	1	SP2701-0913	SP2701-0913	Not Available	SP2701-0913	SP2701-0913	Not Available
19	Seal Spacer	1	28265-0011	28265-0011	Not Available	28265-0011	28265-0011	Not Available
20	"O" Ring	1	X4020-215A	X4020-215A	Not Available	X4020-215A	X4020-215A	Not Available
Flush Seal Kit No. & Contains			28232-0000B	28232-0000B	28232-0000B	28232-0000B	28232-0000B	28232-0000B
21	"O" Ring	1	X4020-237A	X4020-237A	X4020-237A	X4020-237A	X4020-237A	X4020-237A
22	Seal Housing	1	28212-0000	28212-0000	28212-0000	28212-0000	28212-0000	28212-0000
23	Tube	2	21844	21844	21844	21844	21844	21844
24	Seal Spacer(2)	1	28219-0001	28219-0001	28219-0001	28219-0001	28219-0001	28219-0001
25	"O" Ring(2)	1	X4020-215A	X4020-215A	X4020-215A	X4020-215A	X4020-215A	X4020-215A
26	Seal	1	SP2701-0913	SP2701-0913	SP2701-0913	SP2701-0913	SP2701-0913	SP2701-0913
(1) Key 7, 8 & 9 Not Required For Lip Seal Models. (2) Key 9, 24 & 25 Not Required For one piece Shaft								
Optional 23470-0065B High Temperature Impeller Available								

SERVICE INSTRUCTIONS

Dis-Assembly

1. Remove screws (1), endcover and "O" rings (3). Remove screws (11) and slide off body complete with impeller. Push out impeller and "O" ring (6) from body.
2. Remove wearplate (7) and prise out seal seat and cup rubber.
3. Gently lever the spacer (9), (if fitted) and rotary seal off the shaft.

Removal of the following parts is not necessary for normal servicing. However, if required proceed as follows:

4. Remove screws (15) and washers (16) and slide off adaptor (12).
5. Loosen set screws (14) then applying heat and leverage slide off shaft extension. Do not heat damage motor seal and bearing. Do not tamper with motor.

Pumps With Lip Seal:- Push out lip seal (18) from wearplate (17) and loosen set screws to remove spacer (19) and prise out "O" ring (20) from spacer.

Pumps With Flush Seal:- After pulling out rotary seal, unscrew tubes (23) and pull out seal housing (22). If fitted:- Remove seal spacer and prise out "O" ring (25). Remove "O" ring (21) and lip seal (26) from seal housing.

Assembly

1. To assemble shaft extension (if required):- Support motor shaft (fan end). Align set screws (14) with the shaft keyway and press on the shoulder of the shaft extension. Tighten set screws (14).
2. Slide seal spacer (9) (if fitted), on shaft then smear shaft with oil and push rotary seal gently until it touches the spacer or shaft shoulder.
3. Fit adaptor (12) to motor face with screws (15) and washers (16).
4. Fit cup rubber and seal seat into wearplate and slide into position over shaft.
5. Fit impeller into lubricated body with a twisting motion in the same direction as motor. Fit "O" ring (6) into body and slide into position over shaft.
6. Align wearplate and body with adaptor and secure with screws (11) and washers (10). Do not overtighten, a gap between adaptor and body is normal. These screws and endcover screws should be tightened to a torque of 2.2 Nm.
7. Fit "O" ring (3) into body and place endcover over body and secure with screws (1).

Pumps With Lip Seal:- Fit "O" ring (20) into seal spacer (19) and smear spacer and shaft with lubricating oil. Slide spacer over shaft and secure with set screws to dimension shown. Press lip seal (18) into wearplate (17) and slide into position over shaft, then follow on from step 5 above.

Pumps With Flush Seal:- (shafts with seal spacer (24)). Fit "O" ring (25) under seal spacer and smear both spacer and shaft with oil and slide spacer up to shaft shoulder. Press lip seal (26) into seal housing (22) and slide into position. Fit tubes (23) sealing with PTFE tape. Rotary seal and "O" ring (21) can now be fitted. Then follow step 5 above.

Inspect all parts for wear or damage and replace if necessary.

INSTALLATION DRAWING

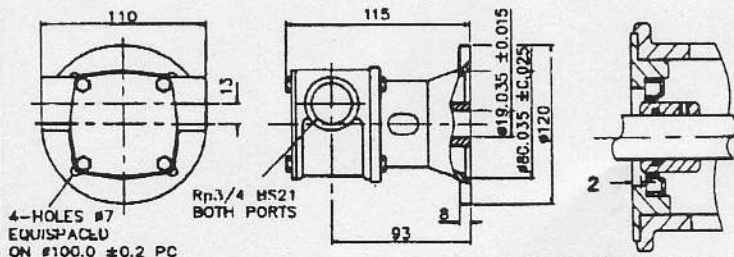

Lip Seal Spacer Position
Dimension (ref. 2mm)

Suitable For (a) 80-B3/B14 Motor Frame To IEC Std
(b) Up to 2.5 Bar Differential Pressure