



# Model 18825-0010

## ENGINE COOLING SELF-PRIMING PUMP

### FEATURES

Body:	Bronze
Bearing Housing:	Bronze
Impeller:	Jabsco Neoprene Compound
Shaft:	Stainless Steel
Shaft Seal:	Carbon-Ceramic Face Type
Bearings:	Sealed Ball Bearing
Ports:	1-1/2" ID Hose
Pulley:	6-1/2" Full Grip "A" Belt
Shipping Weight:	7-1/2 lb

### INSTALLATION AND OPERATION

The pump may be mounted in any position. The direction of rotation of the pump determines the location of the intake and discharge ports (refer to dimensional drawings). Before installing, rotate the pump shaft in the direction of the normal operating rotation of the engine on which the pump will be mounted. The mounting bracket used to support the pump must be designed to enable adjustment of the pump position for proper drive belt tension.

Attach the pump to the mounting bracket using 3/8" – 16 hex heads screws. The pump mounting holes are tapped to this thread size.

Put pulley drive belt over both the drive pulley and the pump pulley. An "A" section belt should be sufficient to drive the 18825-0010 pump. Position the pump to allow 1/2" deflection of the drive belt midway between the engine and pump pulleys. Secure the pump mounting brackets. Attach 1-1/2" ID hose to the ports and clamp using two stainless steel band clamps per port (be sure to attach the water intake line to the proper pump port).

**WARNING** Injury hazard. Exposed pulleys and belts can cause injury. Install shield around pulleys and belts. Stay clear while machinery is operating.



Be sure that all suction lines are airtight so that the pump will self prime. Start the engine and run at low speed. This pump depends on the water for lubrication. DO NOT RUN DRY for more than 30 seconds. Lack of water will damage the impeller. This pump is designed for liquids between 45° and 180° F. Pumping colder water will shorten impeller life and if normal operation is in water colder than 45°, the standard impeller should be replaced with a 920-0008 natural rubber impeller.

Cooling system should be designed so the cooling pump operates with a maximum of 15 psi output pressure.

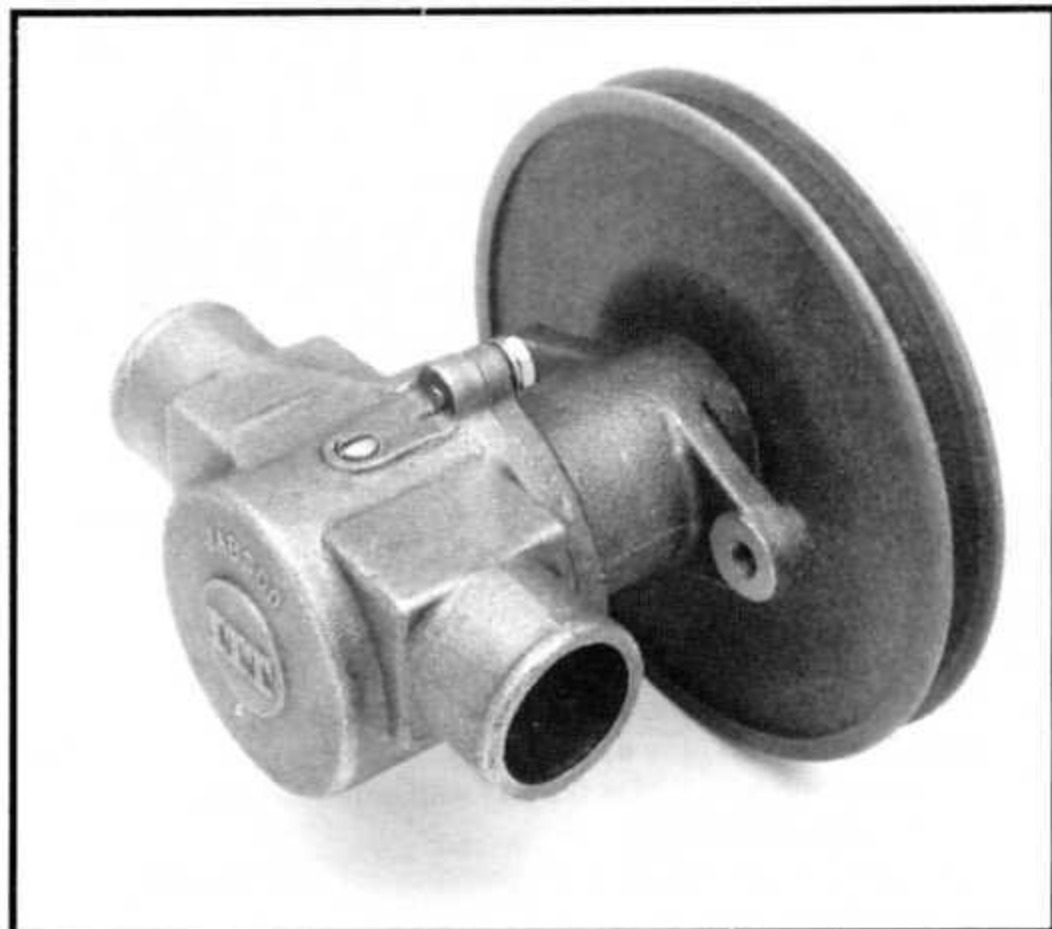

Model 18825-0010

### APPLICATION

Marine engine cooling  
 MerCruiser† V-8 Diesels  
 Marine Power V-8 Diesels

### WINTERIZING

Drain the pump by loosening the impeller housing bolts and loosening the housing. Flush cooling system with an ethylene glycol base antifreeze. NOTICE: Do not use a petroleum based rust inhibitor in the pump. Pump damage can result.

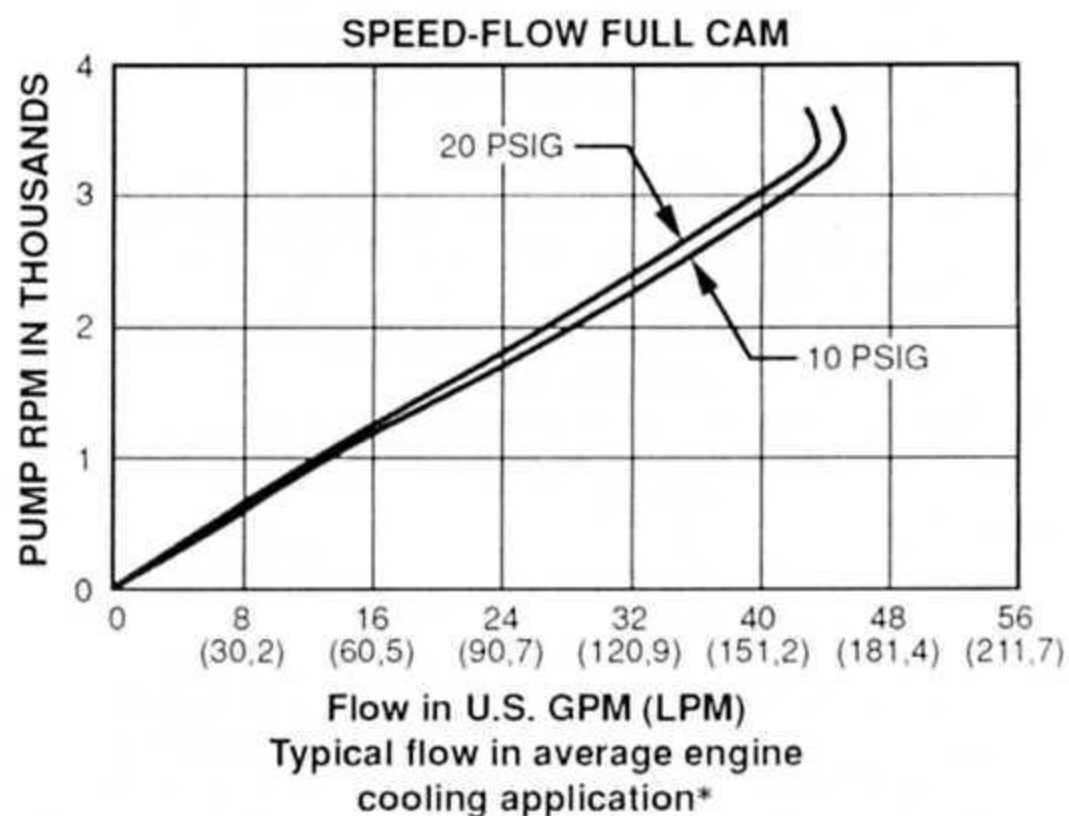

\* Average engine cooling applications have discharge pressures of 10-15 psi (69-104 kPa) and intake vacuums of 3-5 inches of mercury (76-127 mmHg).

† MerCruiser is a registered trademark of the Brunswick Corporation.

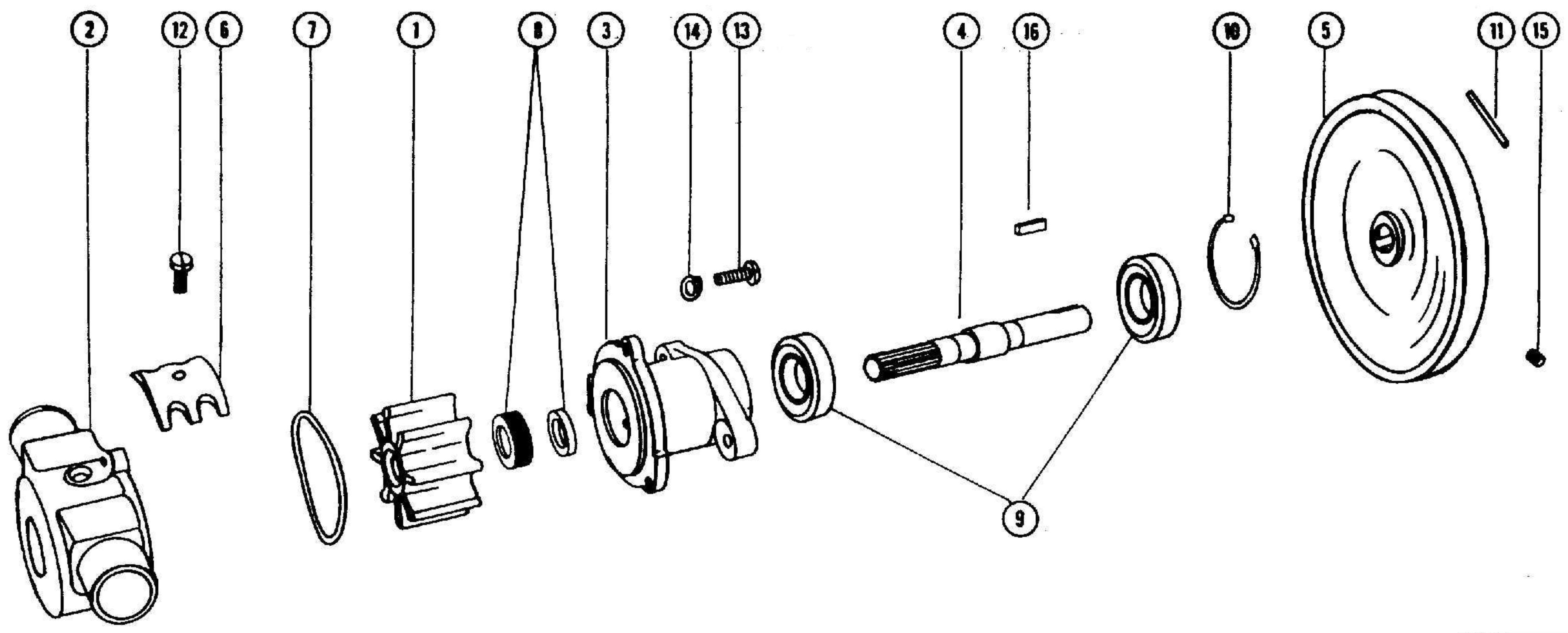

## SERVICE INSTRUCTIONS

### Disassembly

- 1) Remove the three impeller housing screws (key 13).
- 2) Slide impeller housing (key 2) off the bearing housing (key 3) and shaft (key 4) assembly.
- 3) Grasping hub of impeller (key 1) with pliers, remove it from impeller housing.
- 4) Remove cam screw (key 12) from the impeller housing. Slide the cam (key 6) out of the impeller housing.
- 5) Remove the O-ring (key 7) from the impeller housing groove.  
TO REMOVE SEAL ASSEMBLY, THE SHAFT AND BEARING ASSEMBLY MUST BE REMOVED FROM THE BEARING HOUSING (KEY 3).
- 6) Drive roll pin (key 11) out of the pulley and shaft subassembly.
- 7) Loosen set screw and remove pulley (key 5) and key (key 16) from shaft.
- 8) Remove the retaining ring (key 10) out of the bearing housing (key 3).
- 9) Lightly tap the spline end of the shaft. Shaft and ball bearings (key 9) should slide out of the bearing housing. BE CAREFUL NOT TO DAMAGE SPLINE END OF SHAFT.
- 10) Ceramic portion of the seal (key 8) assembly normally will stay on the shaft. THE BRASS/CARBON PORTION OF THE SEAL SHOULD HAVE REMAINED IN THE BEARING HOUSING. Lightly press this portion from the pulley end of the bearing housing toward the impeller end of the bearing housing.
- 11) Press ball bearings (key 9) off the shaft by supporting each bearing on its inner race to prevent damage.

### Assembly

- 1) Clean and inspect all components for wear or damage. Replace all components where needed.
- 2) Lightly lubricate pump shaft (key 4) and press bearings (key 9) onto shaft by applying force to inner race of the bearing. DO NOT APPLY FORCE TO OUTER RACE OF BEARING.
- 3) Slide ceramic (white) portion of seal (key 8) onto spline end of shaft with large white face toward spline end.
- 4) Lightly press the brass/carbon portion of the seal into the bearing housing (key 3); be careful not to damage the carbon face of the seal. Brass face should face toward impeller end of pump and be pressed flush with bottom of counter-bore.
- 5) Lightly press shaft, bearing and shaft seal (ceramic portion) subassembly into bearing housing; be careful not to damage shaft end or seal components during this assembly.

## PARTS LIST

KEY	DESCRIPTION	PART NUMBER	QTY
1*	Impeller and Spline Seal	17937-0001	1
2	Impeller Housing	18826-1000	1
3	Bearing Housing	18943-1000	1
4	Shaft	18827-1000	1
5	Pulley	18753-0006	1
6	Cam	18829-1000	1
7*	O-Ring	18753-0005	1
8*	Seal	96080-0080	1
9	Ball Bearing	92600-0120	2
10†	Retaining Ring	See Hrdw. Kit	1
11†	Roll Pin	See Hrdw. Kit	1
12	Cam Screw	91004-0090	1
13	Screw Kit (3 Ea. with Washers)	18753-0001	1
14	Split Washer	See Screw Kit	
15†	Set Screw	See Hrdw. Kit	1
16†	Key	See Hrdw. Kit	1
	Service Kit	90171-0001	
	Hardware Kit	18753-0010	

\* Included in Service Kit

† Included in Hardware Kit

- 6) Replace bearing retaining ring (key 10) into bearing housing.
- 7) Slide pulley (key 5) onto shaft. Make sure that roll pin hole in shaft lines up with hole in pulley.\*\*
- 8) Drive roll pin (key 11) into pulley and shaft and tighten set screw.
- 9) Apply a thin coat of sealant to convex side of cam (key 6) and threads of cam screw (key 12), and fasten cam to impeller housing.
- 10) Slide impeller (key 1) onto shaft spline and place spline seal in impeller.
- 11) Place O-ring (key 7) into groove in impeller housing and cam subassembly. Lubricate impeller bore. With a twisting motion, slide the impeller housing over the impeller. Be sure the direction the impeller blades are bent matches the direction of normal engine and pump rotation.
- 12) Fasten impeller housing to bearing housing with the three machine screws and washers (key 13 and 14).
- 13) TEST pump following instructions under **Installation and Operation** section.

\*\* If the roll pin hole cannot be aligned through pulley and shaft, drill a new 1/8" hole for roll pin at an angle as near to 90° as possible from original hole. While avoiding the shaft keyway and key, center punch pulley hub or file a flat spot on hub to ease start of drilling procedure.

# DIMENSIONAL DRAWING

inches (millimetres)

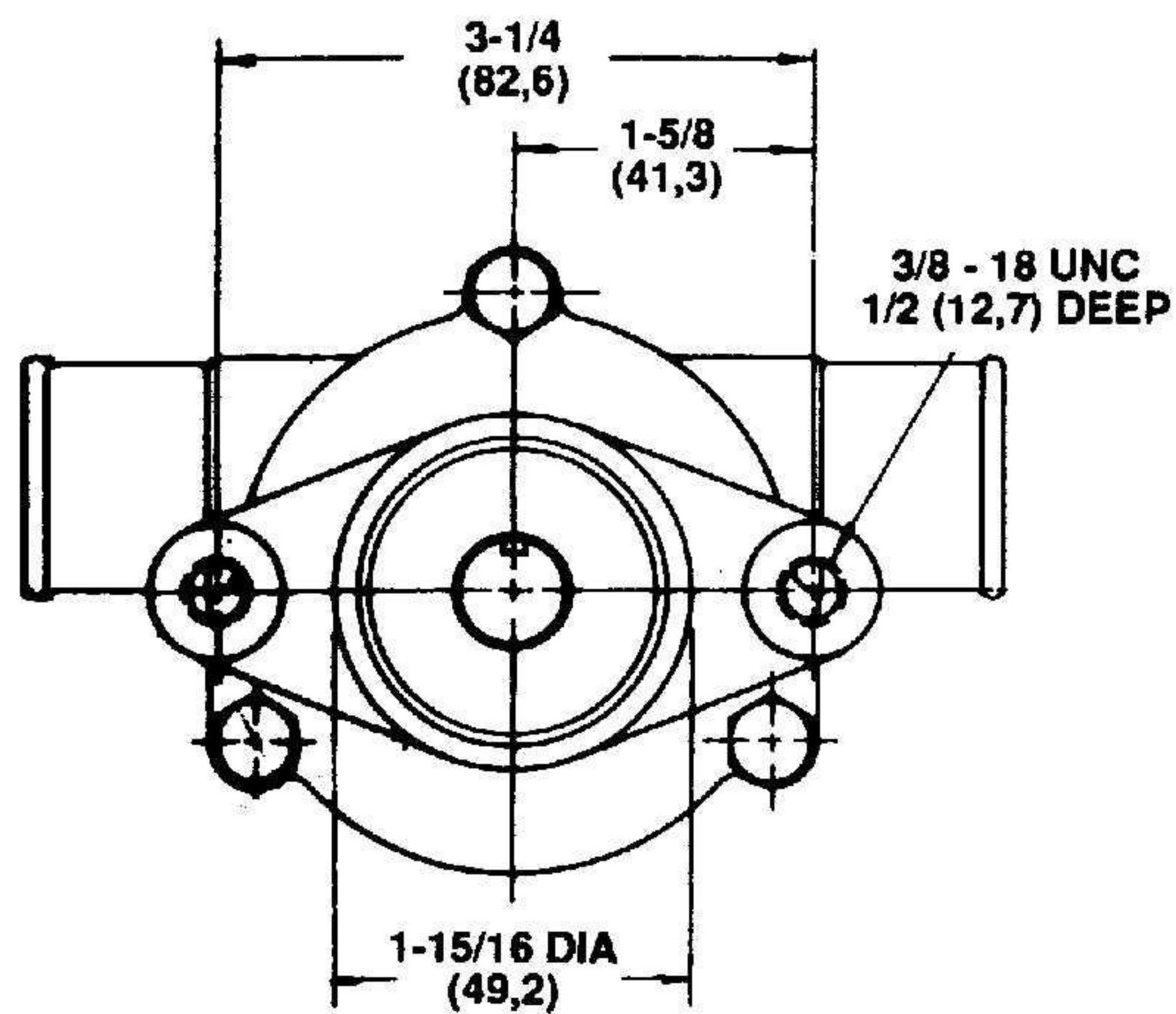

PULLEY NOT SHOWN

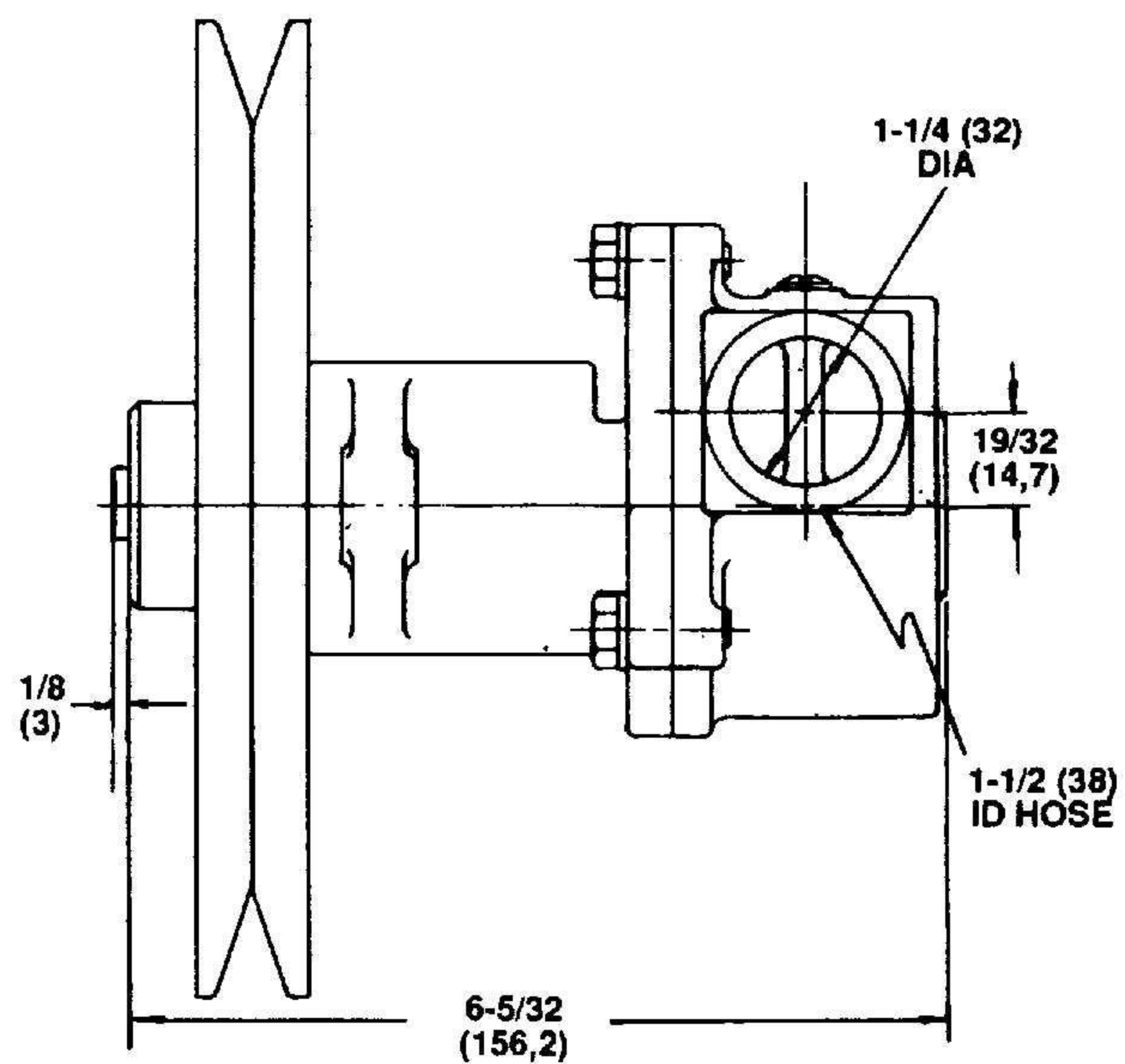
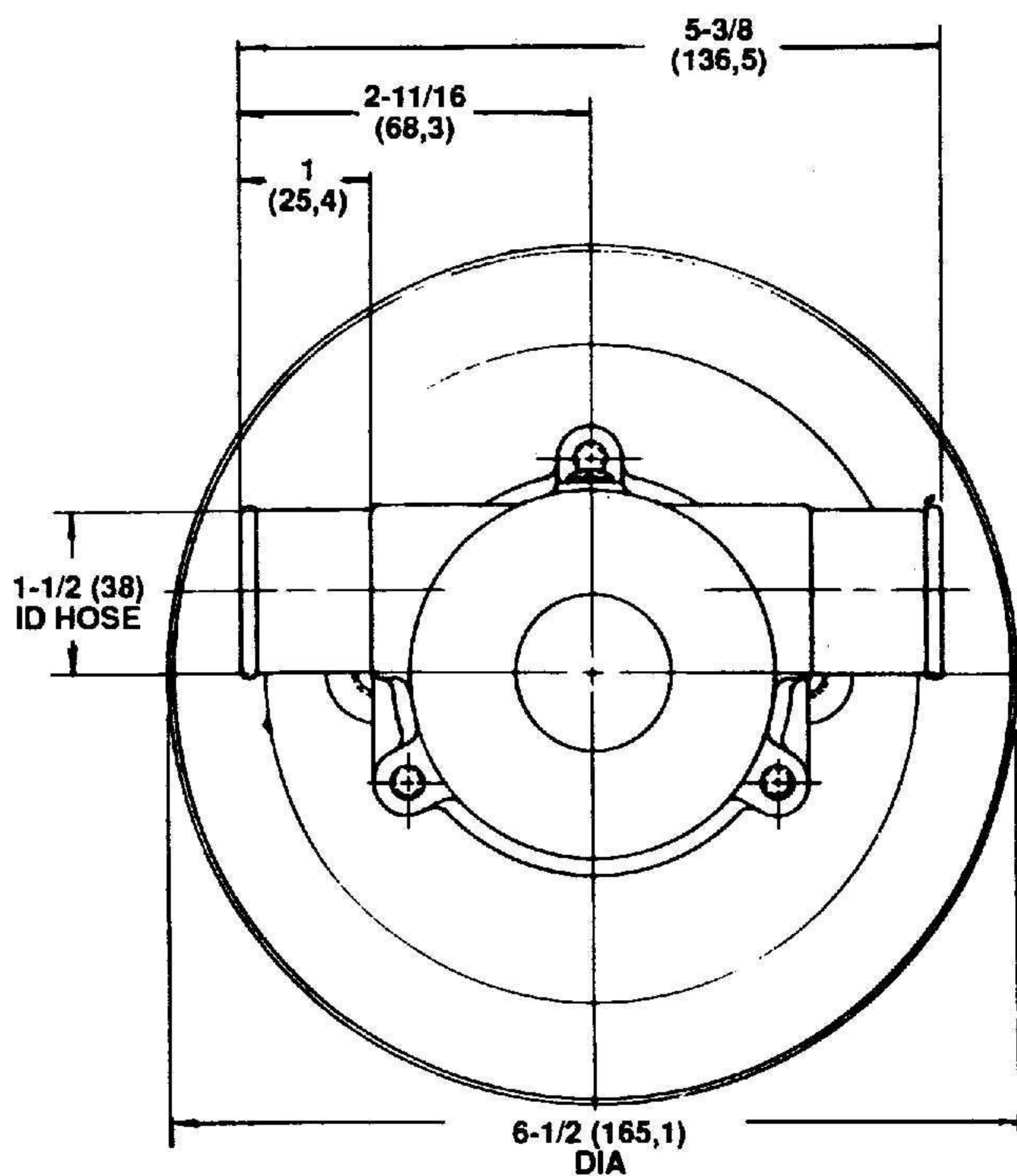
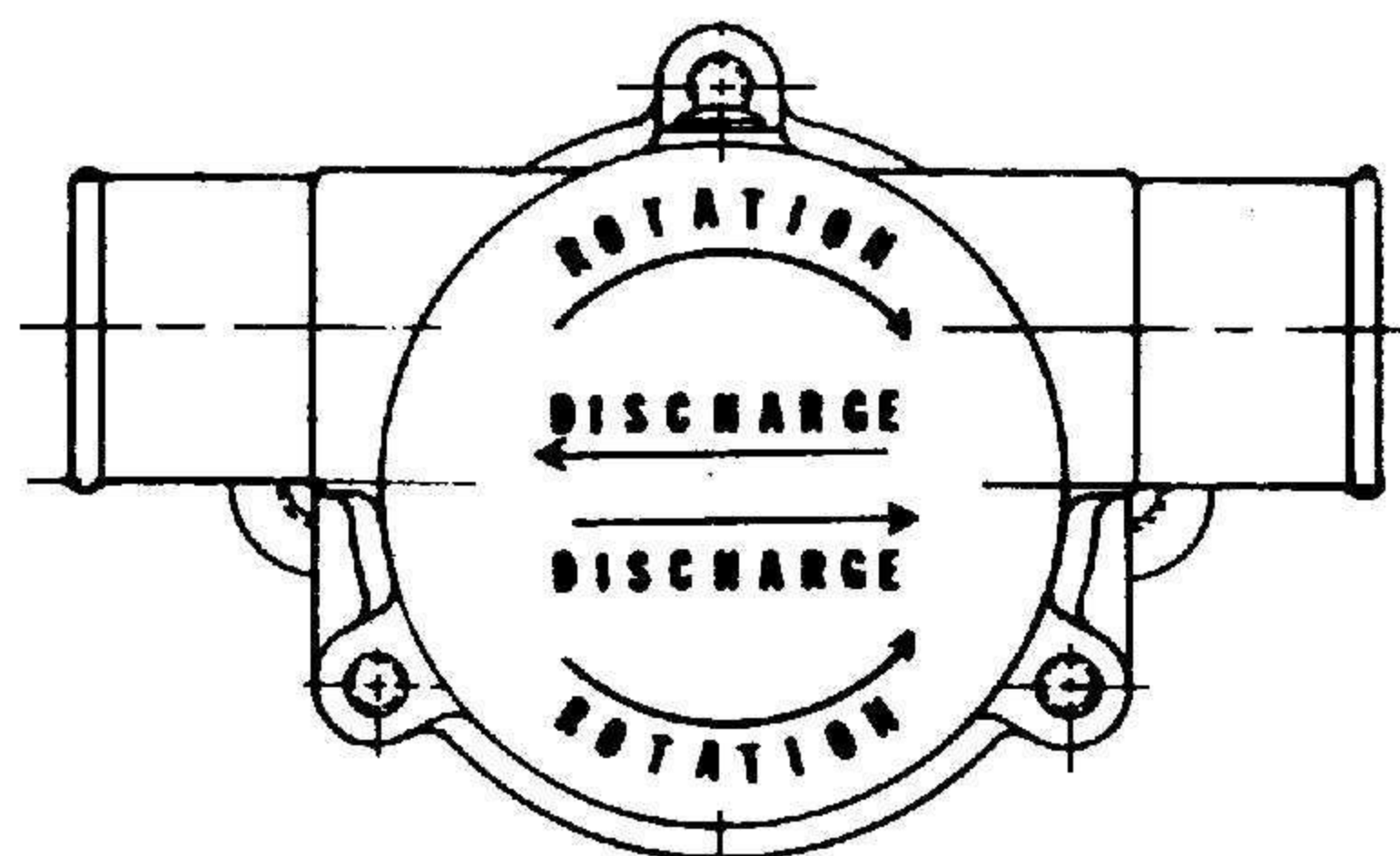
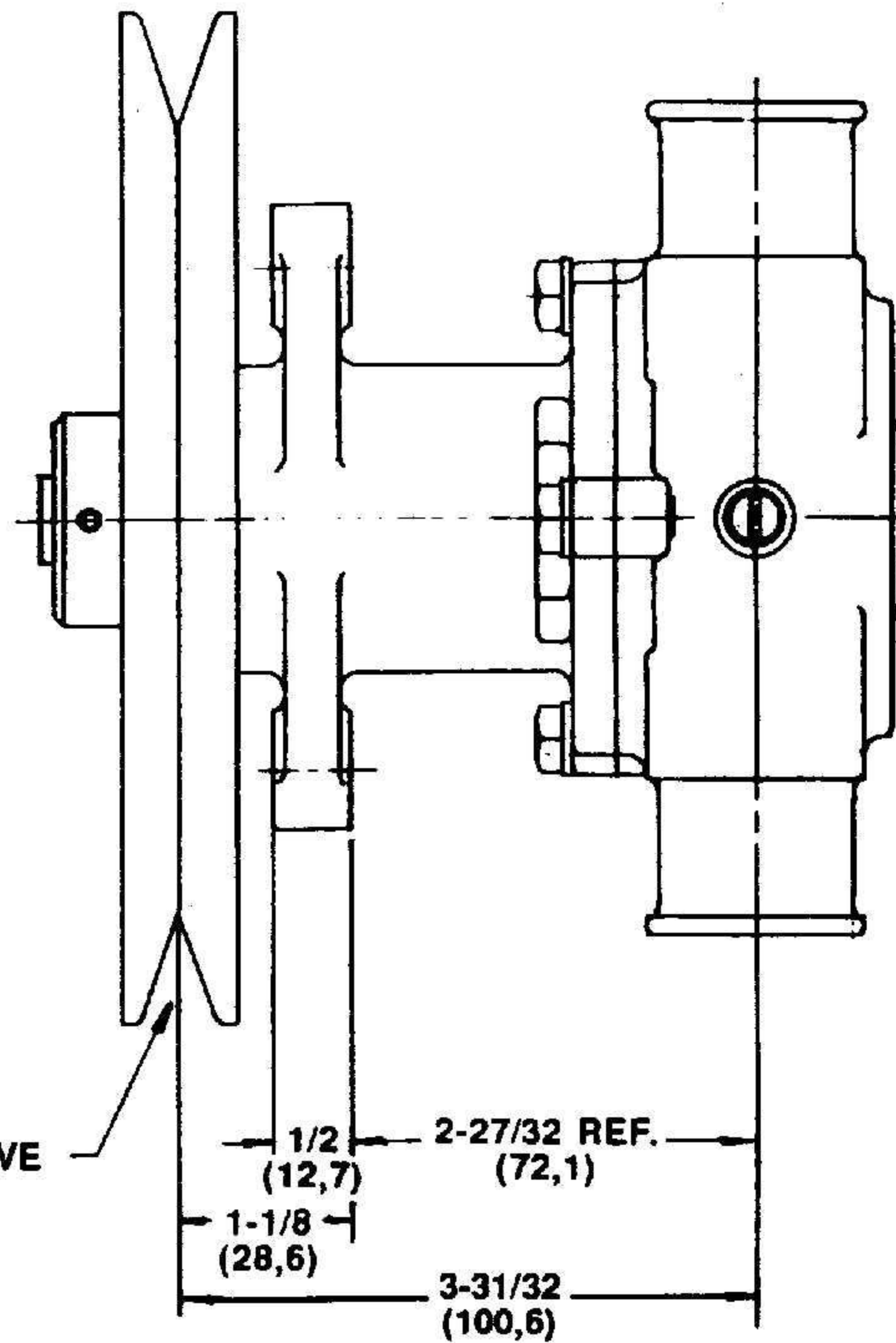

# One Year Limited Warranty

**A. LIMITED WARRANTY:** ITT warrants that at the time of shipment, the products manufactured by ITT and sold hereunder shall be in conformity with applicable written specifications and descriptions referred to or set forth herein, free from defects in material and workmanship, merchantable, and suitable for a particular purpose, provided such is implied by State law under the circumstances of this sale.

## B. WARRANTY ADJUSTMENT:

1. ITT agrees to repair or furnish a replacement for, but not to remove or install, any product or component thereof which, within one (1) year from date of purchase, shall upon test and examination by ITT prove defective within the above warranty. Receipt verifying purchase date is required to obtain adjustment.
2. Buyer shall notify ITT of any defect within this warranty no later than ninety (90) days after the defect is discovered.
3. No product will be accepted for return or replacement without the prior written authorization of ITT. Upon such authorization, and in accordance with instructions from ITT, the product will be returned to ITT, shipping charges prepaid by Buyer. Products returned to ITT will be addressed as follows:

**ITT JABSCO**  
**1485 Dale Way**  
**Costa Mesa, California 92626-3998**

Or to such alternate locations as may be designated on the product, its container, or this sheet.  
Repair or replacement made under this warranty will be shipped prepaid to Buyer.

## C. EXCLUSIONS FROM WARRANTY AND LIMITATION OF LIABILITY:

1. The foregoing warranty is limited solely as set forth herein and applies only for the period designated above.
2. ITT SHALL NOT BE LIABLE FOR ANY LOSS, DAMAGE, SPECIAL OR CONSEQUENTIAL DAMAGE OF ANY KIND, WHETHER BASED UPON WARRANTY, CONTRACT, NEGLIGENCE, OR STRICT LIABILITY ARISING IN CONNECTION WITH THE SALE, USE, OR REPAIR OF THE PRODUCT.
3. THE MAXIMUM LIABILITY OF ITT IN CONNECTION WITH THIS WARRANTY SHALL NOT IN ANY CASE EXCEED THE CONTRACT PRICE FOR THE PRODUCT CLAIMED TO BE DEFECTIVE OR UNSUITABLE.
4. This warranty does not extend to any product manufactured by ITT which has been subjected to misuse, neglect, accident, improper installation, or use in violation of instructions furnished by ITT.
5. This warranty does not extend to or apply to any unit which has been repaired or altered at any place other than ITT's factory, or by persons not expressly approved by ITT, nor to any unit the serial number, model number, or identification of which has been removed, defaced or changed.
6. Components manufactured by any supplier other than ITT shall bear only that warranty made by the manufacturer of that product.
7. This warranty applies to products defined as "consumer products" by the Consumer Product Warranties Act as from time to time amended.

**D. CONSUMER RIGHTS:** This warranty gives you specific legal rights, and you may have other rights which vary from state to state. Some states do not allow exclusion or limitation of damages.

**STANDARD WARRANTY:** If the products manufactured and sold hereunder are not Consumer Products, the warranty extended to Buyer shall be as set forth in subparagraphs (A), (B), and (C), **EXCEPT THAT ALL EXPRESS OR IMPLIED WARRANTIES OR MERCHANTABILITY OR SUITABILITY FOR ANY PARTICULAR PURPOSE ARE EXCLUDED.**

# ITT Jabsco

A Unit of ITT Fluid Technology Corporation



**U.S.A.**  
ITT Jabsco  
1485 Dale Way, P.O. Box 2158  
Costa Mesa, CA 92628-2158  
Tel: (714) 545-8251  
Fax: (714) 957-0609

**UNITED KINGDOM**  
ITT Jabsco  
Bingley Road, Hoddesdon  
Hertfordshire EN11 0BU  
Tel: +44 (0) 1992 450145  
Fax: +44 (0) 1992 467132

**CANADA**  
ITT Fluid Products  
55 Royal Road  
Guelph, Ontario N1H 1T1  
Tel: (519) 821-1900  
Fax: (519) 821-2569

**JAPAN**  
NHK Jabsco Company Ltd.  
3-21-10, Shin-Yokohama  
Kohoku-Ku, Yokohama, 222  
Tel: 045-4758906  
Fax: 045-475-8908

**GERMANY**  
MINTEC GmbH  
Oststrasse 28  
22844 Norderstedt  
Tel: +49-40-53 53 73 -0  
Fax: +49-40-53 53 73 -11