

JABSCO®

Model 18330-SERIES

Model 18330-SERIES

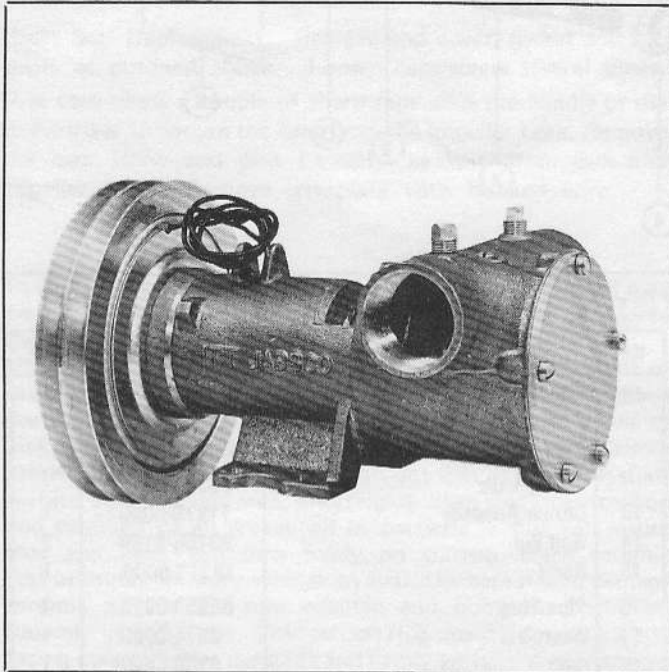

SELF-PRIMING PUMPS

Electro-Magnetic Clutch Units

FEATURES

| | |
|------------------|---------------------------|
| Body: | Bronze |
| Impeller: | Jabsco Nitrile Compound |
| Shaft: | Brass |
| Ports: | 2" NPT |
| Seal: | Carbon-Ceramic Face Type |
| Bearings: | Sealed Ball Bearings |
| Shipping Weight: | 18330 - 29 Lbs. (13,2 kg) |

STANDARD MODELS

| Model | Voltage |
|------------|---------|
| 18330-0000 | 12 Vdc |
| 18330-0001 | 24 Vdc |
| 18330-0002 | 32 Vdc |

APPLICATIONS

MARINE: Engine cooling, Pumping bilges, Washdowns, Circulating water in bait tanks, Utility dock side pump.

INDUSTRIAL: Circulating and transferring, Velocity-mixing, Return spill, Sump drainage, Chemicals, Pharmaceuticals, Soap, Liquors, Ink, Dyes, Alcohol, Tanning Liquors, Glycerine, Brine, etc.

FARMING: Pumping water for stock, Pumping water from shallow wells and cisterns.

PUBLIC UTILITIES AND MUNICIPALITIES: Under the hood mounting on service trucks for dewatering and draining meter boxes, manholes, excavations, and truck installation under hood for emergency pumping.

INSTALLATION

Pump may be mounted in any position. Intake and discharge ports are determined by the direction of shaft rotation (refer to dimensional drawing). Before installing, energize clutch and turn pump shaft in direction of shaft rotation. Drive pump with two "A" size belts. Avoid dry-running by using Vacuum Switch Model 4732-0000 for automatic shut-off.

NOTE: MODEL 18330-SERIES IS INTERCHANGEABLE WITH EARLIER PUMP MODEL 10680-SERIES: BASE MOUNTING DIMENSIONS, HEIGHT ABOVE BASE TO SHAFT, AND HEIGHT ABOVE BASE TO PORT CENTERLINE ARE THE SAME.

WARNING

EXPOSED PULLEYS AND BELTS CAN CAUSE INJURY. INSTALL SHIELD AROUND PULLEYS AND BELTS.

WIRING

Connect wires as shown for manual on-off operation. Install proper size fuse (see Electrical Specification Chart) in positive lead ahead of switch and as close to power source as possible. For remote control or automatic shutoff operation, see data sheet on Model 4732-0000 Vacuum Switch Kit (Form 43000-0024). For complete wiring instructions see diagram on page 2.

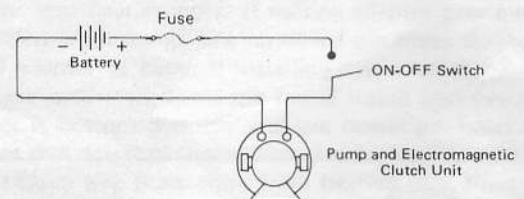

CLUTCH ELECTRICAL SPECIFICATIONS

| MODEL | VOLTAGE | AMP DRAW | FUSE SIZE |
|------------|---------|----------|-----------|
| 18330-0000 | 12 | 4 | 7 |
| 18330-0001 | 24 | 2 | 4 |
| 18330-0002 | 32 | 1.5 | 3 |

OPERATION

Pump will self-prime at low or high speeds. Make sure that all connections are airtight. 12 Volt models are equipped with mechanical clutch engagement screws in case of electrical failure. To mechanically engage clutch, loosen locking nuts, tighten allen head screws and retighten locking nuts. Reverse procedure to disengage clutch. **DO NOT RUN PUMP DRY FOR MORE THAN 30 SECONDS. LACK OF WATER FLOW MAY DAMAGE IMPELLER.** To drain pump, loosen end cover screws. See Head Capacity Table for head pressures and flow. To avoid costly shutdowns, keep a Jabsco Service Kit on hand.

EXPLODED VIEW

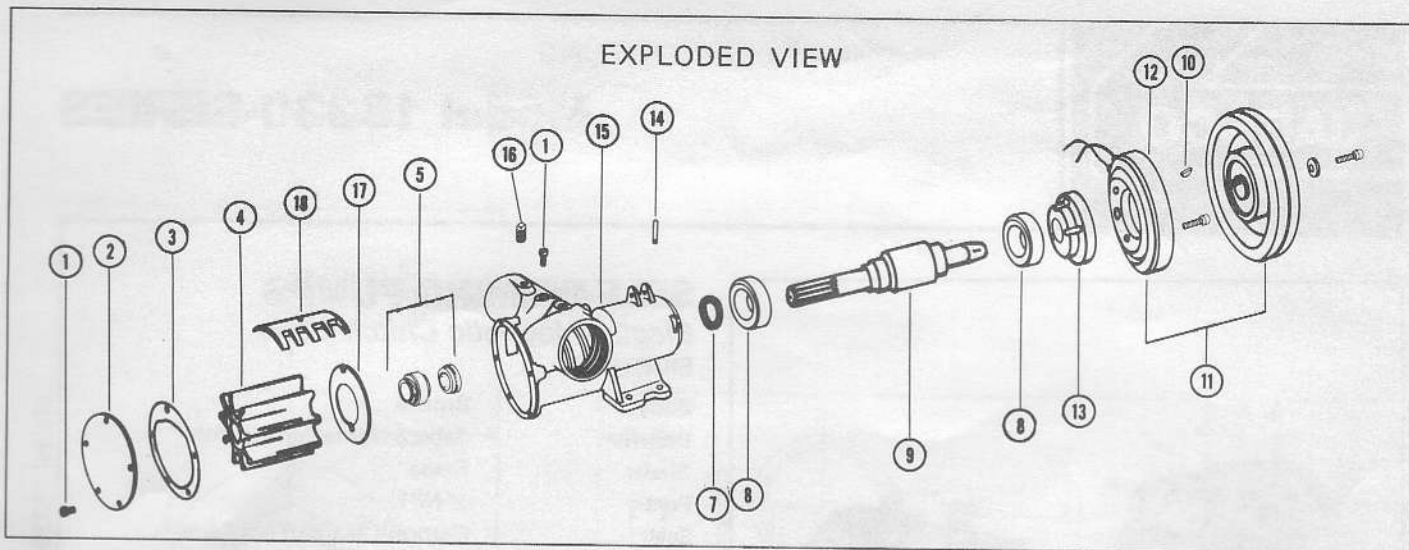

PARTS LIST

| Key | Description | Part Number | Qty. |
|-----|---------------------------|-------------|------|
| 1 | Screw (End Cover and Cam) | 91005-0040 | 6 |
| 2 | End Cover | 12062-0000 | 1 |
| 3 | *Gasket | 816-0000 | 1 |
| 4 | *Impeller | 6760-0001 | 1 |
| 5 | *Seal Assembly (Shaft) | 6408-0000 | 1 |
| 7 | Bearing Seal | 92701-0180 | 1 |
| 8 | Ball Bearing | 92600-0260 | 2 |
| 9 | Shaft | 10677-0010 | 1 |
| 10 | Drive Key | 91401-0100 | 1 |
| 11 | Clutch Assembly | | 1 |
| | 12 Vdc | 92300-0030 | |
| | 24 Vdc | 92300-0061 | |
| | 32 Vdc | 92300-0050 | |

| Key | Description | Part Number | Qty. |
|-----|----------------|-------------|------|
| 12 | Field Coil | | 1 |
| | 12 Vdc | 98022-0500 | |
| | 24 Vdc | 98022-2155 | |
| | 32 Vdc | 98022-0510 | |
| 13 | Clutch Adaptor | 11876-0000 | 1 |
| 14 | Roll Pin | 93100-0160 | 2 |
| 15 | Body | 18313-0000 | 1 |
| 16 | Pipe Plug | 92650-0070 | 2 |
| 17 | Wearplate | 2574-0000 | 1 |
| 18 | Cam | 6988-0000 | 1 |
| | Service Kit | 90254-0001 | |

* Parts contained in Service Kit

NOTES: 1. ALL REPLACEMENT PARTS, (EXCEPT BODY/BEARING HOUSING ASSEMBLY), ARE INTERCHANGEABLE WITH EARLIER PUMP MODEL 10680-SERIES

WIRING DIAGRAM

Remote Control and Automatic Engine Driven Bilge Pump

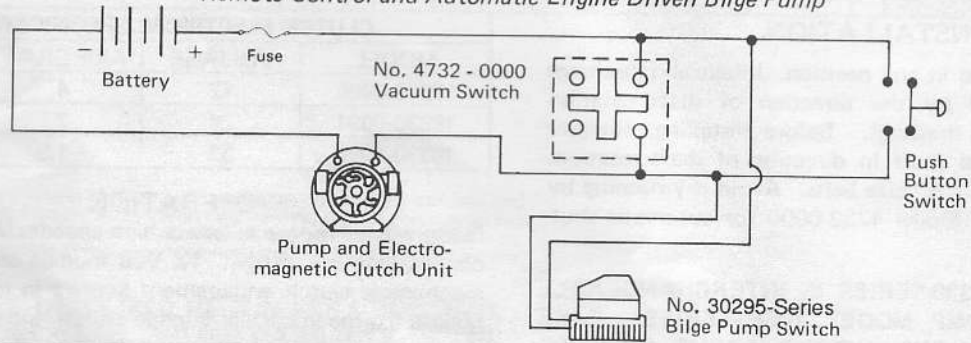

REMOTE CONTROL (When Engine Is Running): Install a pushbutton switch at one or more locations. Depress pushbutton for 2 seconds. If there is water in bilge, pump will operate until dry at which time vacuum switch will stop pump. If no water is in bilge, pump will stop when pushbutton is released.

AUTOMATIC BILGE PUMP (When Engine Is Running): Install No. 30295-Series Automatic Bilge Pump Switch where it will energize clutch at maximum high water level in bilge. When water raises switch float, pump will start. Vacuum switch will maintain closed circuit until bilge is pumped dry. Pump will automatically stop, preventing impeller damage.

SERVICE INSTRUCTIONS

Impeller Replacement: Remove end cover and gasket. Pull impeller out by grasping hub with pliers. With a rotary motion in the direction the pump will be turning, push impeller into the impeller bore. A light coating of grease in the impeller bore will protect impeller during initial dry start up. Install gasket and end cover.

Shaft Seal Replacement: Remove end cover, gasket and impeller as outlined above. Loosen cam screw several times. Give cam screw a couple of sharp raps with the handle of the screwdriver to loosen the cam from the impeller bore. Remove the cam screw and cam (clean sealant from cam and impeller bore). Remove wearplate with hooked wire.

In this pump, either a wave washer seal or coil spring seal may be used. The wave washer is used only if the carbon portion of the seal does not have a coil spring attached.

Using a hooked wire, and taking care not to scratch shaft or seal seat bore, remove all components of seal assembly. Inspect shaft and seal seat bore to be sure sealing surfaces are free of nicks or scratches. Clean shaft surface behind splines to insure proper O-ring seal on shaft. Apply light film of grease on shaft surface behind spline area. Thoroughly clean seal faces (carbon and ceramic) of all grease, oil or particles — this will insure that seal faces will turn freely on startup. Place ceramic seat assembly in body with boot first. Use care not to damage ceramic surface. Be sure ceramic and boot are bottomed squarely in body bore. Slide carbon ring assembly, with carbon facing ceramic, over the shaft and firmly up against the ceramic seat. If carbon portion of seal does not have an integral coil type tensioning spring, slide wave washer over the shaft and against the rubber boot on metal case containing O-ring and carbon. Replace wearplate, aligning notch with dowel pin in body. Apply a thin coat of sealant to top of cam and threads on cam screw and install in impeller bore (leave cam screw loose). Replace impeller, gasket, and end cover. Tighten end cover screws. Tighten cam screw.

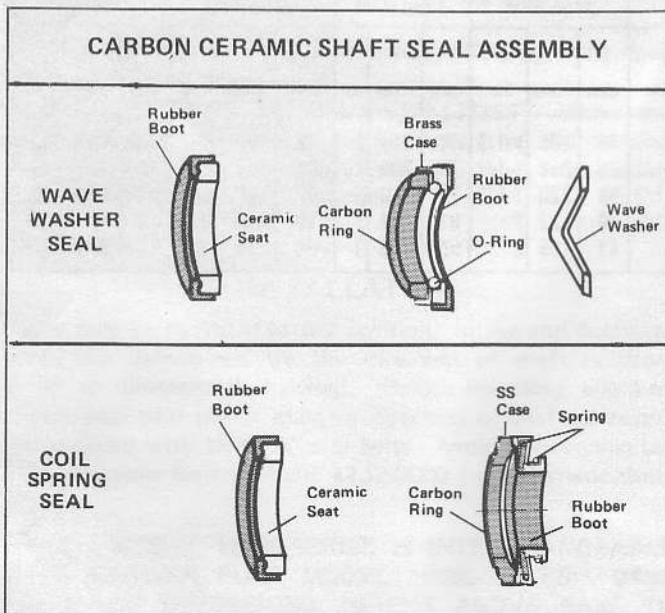

Field Coil Replacement: Remove drive belts from pulley. Disconnect wiring. Remove center bolt and washer (it may be necessary to remove end cover to hold impeller from turning while removing center bolt). Tap pulley with soft mallet to remove from shaft taper. Remove three bolts and washers holding field coil to adaptor. Remove and replace field coil, tightening the three bolts securely. With drive key in place in shaft, replace pulley assembly. Secure to shaft with center bolt and washer (again it may be necessary to hold the impeller from turning to tighten center bolt). Replace drive belts. Do not overtighten belts. A deflection of 1/2" midway between pulley is generally considered normal. Reconnect wiring.

Major Repair: Remove pump from installation.

Disassembly: Remove end cover, gasket, impeller, cam and seal assembly as outlined in "shaft seal replacement". Remove clutch pulley and field coil as outlined in "field coil replacement". Use a punch to drive roll pins (key 14) in towards shaft, approximately 3/8" (10mm). Remove clutch adaptor from body punch roll pins out of adaptor. Press on impeller end of shaft to remove shaft and bearing assembly from body bearing bore. Use screwdriver to pry inner bearing seal from body. Take care not to scratch or damage body bore. If ball bearings are worn or any slight roughness is felt when the bearing is turned, replace both bearings. Support inner race of bearing and press on impeller end of shaft to remove inner bearing. Replace all worn or damaged parts.

Assembly: Support inner race of ball bearing. Insert impeller drive end of well oiled shaft to seat inner bearing firmly against shaft shoulder. Reverse shaft and insert tapered end of shaft through bearing supported on inner race. Press on impeller end of shaft to seat second bearing firmly against shaft shoulder. Wipe shaft free of oil. Lightly grease inner bearing seal and press into body bearing bore seating firmly against shoulder in bearing seal bore with lip facing towards impeller bore. Support impeller end of body, insert impeller end of shaft through bearing seal and press on outer race of outer bearing to position shaft and bearing assembly into bearing bore, firmly against shoulder. Install clutch adaptor into bearing bore. If reusing adaptor previously disassembled from pump, line up dowel pin holes during assembly of adaptor to body. If installing new adaptor (which does not have predrilled dowel pin holes) install into bearing bore until it is bottomed firmly and use dowel pin holes in body to pilot drill dowel pin holes through adaptor, two places. 180° apart. Clean any brass chips from bearing area. Press roll pin into body to secure adaptor. Attach field coil to adaptor with three bolts and washers. Before assembling clutch pulley, turn body over and install seal assembly, wearplate cam and impeller as described in shaft seal and impeller replacement instructions. Turn body over to assemble clutch pulley as outlined in field coil replacement instructions. Complete assembly by installing gasket and end cover.

DIMENSIONAL DRAWING

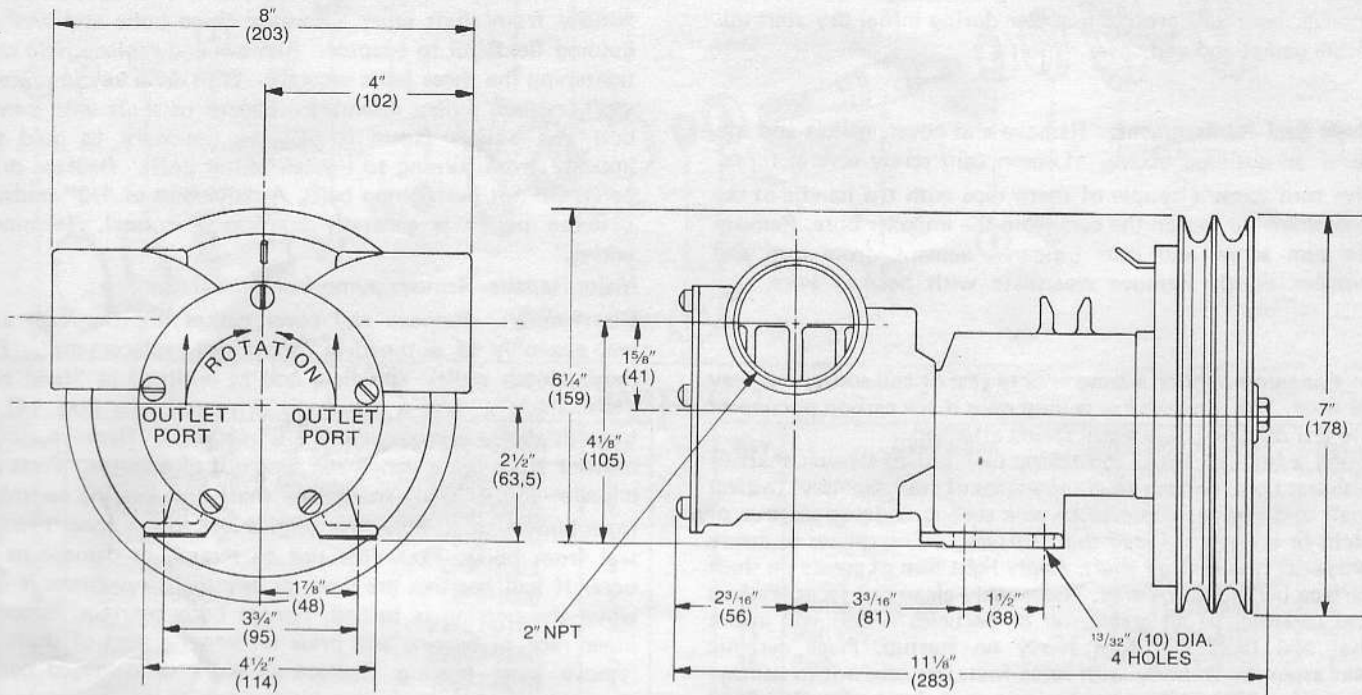

(MILLIMETRE EQUIVALENTS)

Model 18330-SERIES 2" PORTS HEAD CAPACITY TABLE

| TOTAL HEAD | | | | 500 RPM | | | 870 RPM | | | 1160 RPM | | | 1450 RPM | | | 1750 RPM | | | 2100 RPM | | | 2450 RPM | | |
|------------|--------------------|---------------|-----------------|---------|-------|-----|---------|-------|-------|----------|-------|-------|----------|-------|-------|----------|-------|----|----------|-------|----|----------|-------|----|
| PSI | kg/cm ² | Feet of Water | Metres of Water | GPM | ℓ/min | HP | GPM | ℓ/min | HP | GPM | ℓ/min | HP | GPM | ℓ/min | HP | GPM | ℓ/min | HP | GPM | ℓ/min | HP | GPM | ℓ/min | HP |
| 4.3 | 0,3 | 10 | 3,0 | 23 | 87 | 1/2 | 40 | 151 | 1 | 54 | 204 | 1 | 70 | 265 | 1-1/2 | 83 | 314 | 2 | 95 | 360 | 3 | 108 | 409 | 3 |
| 8.7 | 0,6 | 20 | 6,1 | 22 | 83 | 1/2 | 37 | 140 | 1 | 50 | 189 | 1 | 66 | 250 | 1-1/2 | 79 | 299 | 2 | 91 | 344 | 3 | 104 | 394 | 3 |
| 17.3 | 1,2 | 40 | 12,2 | 17 | 64 | 1/2 | 30 | 114 | 1 | 43 | 163 | 1-1/2 | 58 | 220 | 1-1/2 | 71 | 269 | 3 | 82 | 310 | 3 | 93 | 352 | 5 |
| 26.0 | 1,8 | 60 | 18,3 | — | — | — | 22 | 83 | 1-1/2 | 34 | 129 | 1-1/2 | 48 | 182 | 2 | 61 | 231 | 3 | 70 | 265 | 5 | 81 | 307 | 5 |
| 30.3 | 2,1 | 70 | 21,3 | — | — | — | — | — | — | — | — | — | 41 | 155 | 2 | 55 | 208 | 3 | 62 | 235 | 5 | 73 | 276 | 5 |

NOTE: Progressively longer life may be expected as operating pressures and speeds are reduced. Factory Application Engineering assistance suggested for operation in light shaded area and recommended for heavy shaded area. Table shows approximate Head-Flow for new pump in U.S. gallons per minute.

THE PRODUCTS DESCRIBED HEREIN ARE SUBJECT TO THE JABSCO ONE YEAR LIMITED WARRANTY, WHICH IS AVAILABLE FOR YOUR INSPECTION UPON REQUEST.

ITT Jabsco

ITT Fluid Technology Corporation
 1485 Dale Way, P.O. Box 2158, Costa Mesa, CA 92628-2158
 Tel: (714) 545-8251; Fax: (714) 957-0609
 Bingley Road, Hoddesdon, Hertfordshire EN11 0BU, England
 Tel: 0992-467191; Tlx: 263251 G; Fax: 0992-467132