

JABSCO® PUMPS

Self-Priming Pumps

MODEL 14540-0001

FORMERLY PE25-P4

Product Data

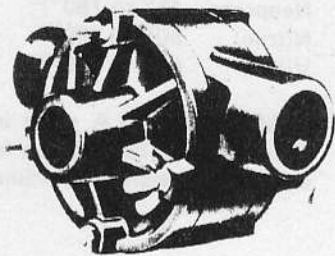

DESIGN FEATURES

Body:	Epoxy Plastic
Impeller:	Neoprene, Nitrile or Viton
Shaft Seal:	Mechanical
Ports:	1" I.P.T.
Shaft:	Type 316 Stainless Steel, Titanium or Hastelloy "B"
Shipping Weight:	8½ lbs. (3.8 kg)

MODEL: 14540-0001

APPLICATIONS

Designed for: "transfers," "circulation," "spill returns," "filtration" and "filling line" use. Easily handles pure solutions, foaming liquids, emulsions, suspended solids, gels and ferments. Because the plastic pump is resistant to corrosion and metallic contamination it is widely used for pumping photo chemicals, plating compounds, lab solutions, pharmaceuticals, cosmetics, weak acids, alkalies, liquid fertilizers, insecticides, dyes, detergents, waxes and many more.

See the JABSCO Pump "Chemical Resistance Table", which has been prepared to help you select the most suitable impeller and pump material.

HEAD CAPACITY TABLE

TOTAL HEAD		500 RPM		1160 RPM		1750 RPM	
PSI (kg/sq cm)	Ft. of Water (meter)	GPM (L/min)	H.P.	GPM (L/min)	H.P.	GPM (L/min)	H.P.
4.3 (.30)	10 (3.0)	8.0 (30.3)	1/6	16.5 (62.5)	1/3	25.5 (96.5)	3/4
8.7 (.61)	20 (6.1)	7.5 (28.4)	1/4	16.0 (60.5)	1/3	24.6 (93.1)	3/4
17.3 (1.21)	40 (12.2)	5.4 (20.4)	1/4	14.3 (54.1)	1/3	23.0 (87.1)	3/4
26.0 (1.83)	60 (18.3)			12.8 (48.4)	1/2	21.0 (79.5)	1
34.6 (2.43)	80 (24.4)					18.0 (68.1)	1

VARIATIONS AVAILABLE

MODEL	DESCRIPTION
14540-0003	Stainless Steel Shaft Nitrile Impeller
14540-0004	Stainless Steel Shaft Viton Impeller Viton "O" Rings Viton Carbon/Ceramic Seal
14540-0021	Hastelloy B Shaft Neoprene Impeller
14540-0023	Hastelloy B Shaft Nitrile Impeller
14540-0024	Hastelloy B Shaft Viton Impeller Viton "O" Rings Viton Carbon/Ceramic Seal
14540-0151	Titanium Shaft Neoprene Impeller
14540-0153	Titanium Shaft Nitrile Impeller
14540-0154	Titanium Shaft Viton Impeller Viton "O" Rings Viton Carbon/Ceramic Seal

JABSCO PRODUCTS ITT

Form 43000-0129 Rev. 10-76

OPERATING INSTRUCTIONS

- 1. INSTALLATION** — Pump may be mounted in any position. The rotation of the pump shaft determines the location of the pump's intake and discharge ports. Refer to Dimensional Drawing. Before starting, turn the pump shaft in the direction of the operating rotation.
- 2. DRIVE** — Belt or Direct with flexible coupling. **DIRECT DRIVE** — Clearance should be left between drive shaft and pump shaft when installing coupling. Always mount pump and align drive shaft before tightening the coupling set screw.
- 3. SPEEDS** — 100 RPM to the maximum shown in the performance table. For longer pump life, operate at lowest possible speeds.
- 4. SELF-PRIMING** — Primes at low or high speeds. For vertical dry suction lift of 10 feet (3.0M), a minimum of 800 RPM is required. Pump will produce suction lifts up to 22 feet (6.7M) when wetted. **BE SURE SUCTION LINES ARE AIR-TIGHT OR PUMP WILL NOT SELF-PRIME.**
- 5. RUNNING DRY** — Unit depends on liquid pumped for lubrication. **DO NOT RUN DRY FOR MORE THAN 30 SECONDS.** Lack of liquid will burn the impeller and damage the plastic components.
- 6. CAUTION** — If corrosive fluids are handled, pump life will be prolonged, if flushed with water after each use or after each work day. For further information contact factory.
- 7. PRESSURES** — For continuous operation, pressure should not exceed 30 psi (2.1 kg/sq cm).
- 8. TEMPERATURES:**
Neoprene: 45° to 180°F
Nitrile: 50° to 180°F
Viton: 60° to 180°F
- 9. SPARE PARTS** — A spare impeller & seal should be kept on hand to eliminate excessive downtime.

DISASSEMBLY AND ASSEMBLY INSTRUCTIONS

- Disassembly Steps □ Assembly Steps

TO REPLACE IMPELLER

- Step #1. ● Remove wing nuts, washers and end cover.
- Step #2. ● Remove pump head from seal housing. Remove "O" rings from body grooves.
- Step #3. ● Push impeller from body bore.
- Step #4. □ Install new impeller in lubricated body bore by grasping hub and with a rotary motion push it into the body bore. Replace "O" rings in body grooves.
- Step #5. □ Position the body over the through bolts against the seal housing.
- Step #6. □ Install end cover and secure with washers and wing nuts.

TO REPLACE SEAL ASSEMBLY

- Step #7. ● Follow steps 1●, 2●, and 3●.
- Step #8. ● Remove seal housing. Insert screw driver through seal seat bore and pry seat and grommet from seal housing.
- Step #9. ● Remove seal and seal spring from shaft.
- Step #10. □ Install seal spring on shaft against shaft washer. Lubricate seal with water and slide on shaft with carbon facing away from spring.
- Step #11. □ Install ceramic seal seat in grommet with grooved face towards grommet. Lubricate outer grommet surface with water and push seal seat assembly into seal housing with ceramic seal facing out of seal seat bore. Assemble seal housing over through bolts so seal and seat faces contact.
- Step #12. □ Assemble impeller, body, and end cover as in steps 4□, 5□, and 6□.

TO SERVICE BEARING HOUSING

- Step #13. ● Follow steps 1●, 2●, 3●, 8●, and 9●.
- Step #14. ● Use a thin screw driver blade to pry inner bearing seal from pedestal. Use retaining ring pliers to remove retaining ring.
- Step #15. ● Press on drive end of shaft to remove shaft and bearing assembly from pedestal.
- Step #16. ● Use thin screw driver blade to pry outer bearing seal from pedestal.
- Step #17. ● Support inner face of one bearing and press shaft through and out of bearing. Reverse shaft, support inner face of second bearing and press shaft through and out of bearing.
- Step #18. □ Support inner race of ball bearing, press shaft through bearing until shaft shoulder bottoms firmly against bearing inner race. Reverse shaft and repeat procedure to assemble second bearing on shaft.
- Step #19. □ Push shaft and bearing assembly into bearing housing from body end, secure with retaining ring in housing.
- Step #20. □ Press inboard bearing seal in bearing housing with lip facing impeller bore.
- Step #21. □ Press outboard bearing seal in bearing housing with lip facing outwards.
- Step #22. □ Assemble balance of pump parts following steps 10□, 11□, and 12□.

EXPLODED VIEW

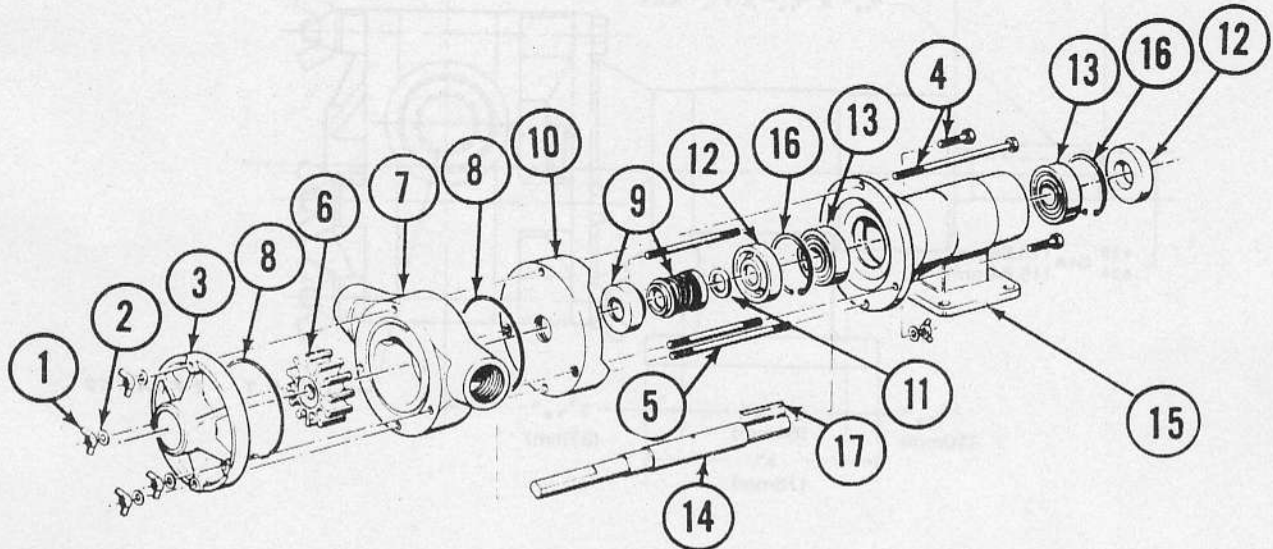

PARTS LIST

KEY	DESCRIPTION	PART NUMBER	QTY. REQ.	
1	Wing Nut	91107-0030	5	\$3.11
2	Washer	91601-0040	5	\$.80
3	End Cover	17434-0000	1	\$51.15
4	Bolt - 4 1/2" Bolt - 3/4"	91095-0140	1	\$2.75
		91095-0240	2	\$.68
5	Stud - 4 3/4" Stud - 3 3/4"	91090-0100	1	\$4.70
		91090-0110	1	\$3.45
6	Impeller Neoprene Nitrile Viton	14282-0001	1	\$50.30
		14282-0003		
		14282-0004		
7	Body	14934-0000	1	\$180.05
8	"O" Ring Standard Viton	92000-0310	2	\$10.20
		92000-0880		
9	Seal Standard Viton	96080-0040	1	\$113.80
		96080-0210		
10	Seal Housing	14533-0000	1	\$67.05
11	Washer	14536-0000	1	\$2.50
12	Bearing Seal	496-0000	2	\$12.25
13	Ball Bearing	92600-0120	2	\$11.93
14	Shaft Stainless Steel Hastelloy "B" Titanium	14538-0010	1	\$201.35
		14538-0020		
		14538-0150		
15	Bearing Housing	1269-0000	1	\$169.35
16	Retaining Ring	91700-2500	2	\$5.20
17	Key	91402-0110	1	\$7.20

*Optional as Spare Parts:
 96080-0090 Buna 'N', Carbon/Carpenter 20
 14546-0000 Carpenter 20 Seal Seat

DIMENSIONAL DRAWINGS

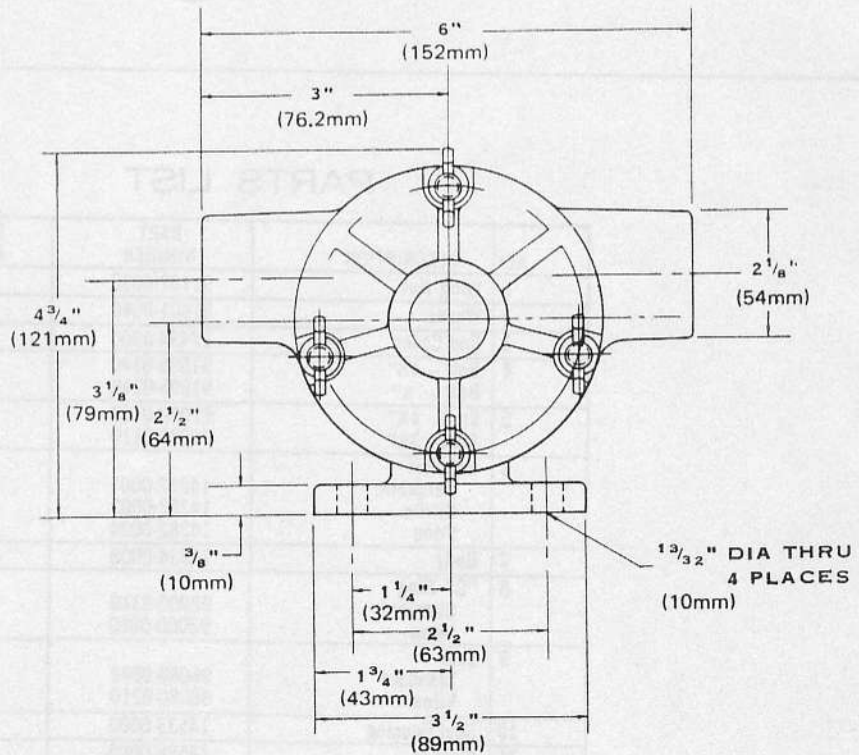
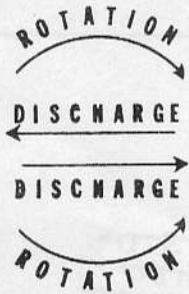
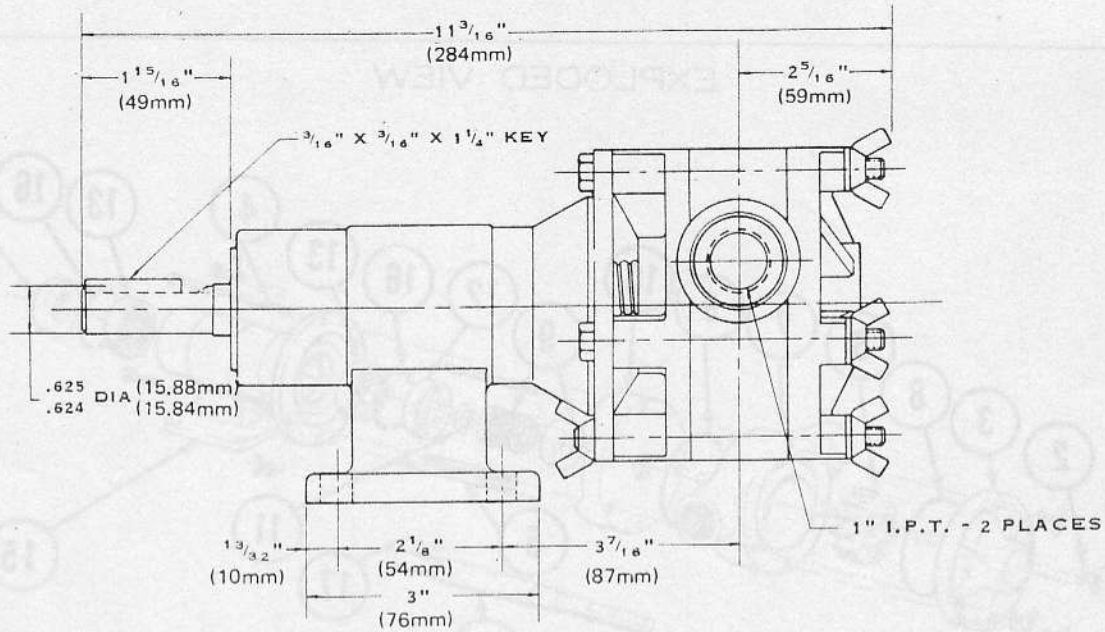

JABSCO PRODUCTS **ITT**

A Unit of International Telephone and Telegraph Corporation, 1485 Dale Way, Costa Mesa, California 92626
 Telephone: (714) 545-8251