

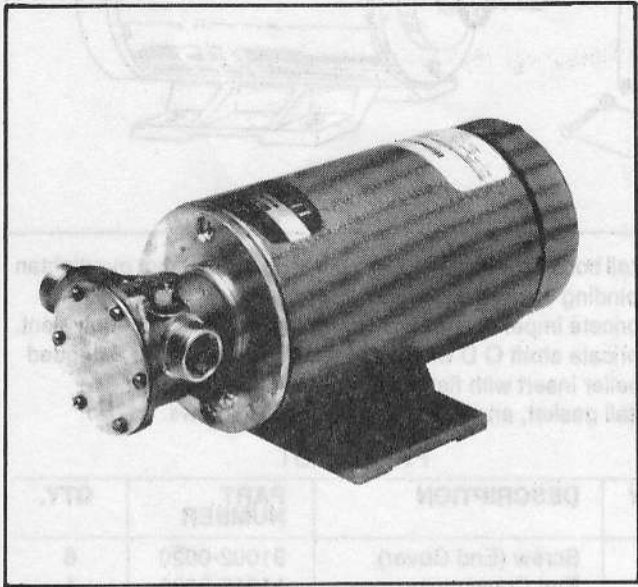

Model 11810-0121 12 volts dc 11810-0241 24 volts dc 11810-0321 32 volts dc



SELF-PRIMING PUMPS FEATURES

- Body:** Bronze Construction
- Impeller:** Jabsco Neoprene Compound
- Shaft:** Steel Motor Shaft Protected by Stainless Steel Impeller Sleeve
- Wearplate:** Replaceable
- Shaft Seal:** Lip Type
- Ports:** Both 3/4" Garden Hose External Thread and 1/2" Internal Pipe Thread
- Motor:** 1/3 hp/1800 RPM, Continuous Duty
- Weight:** 22 lbs (Approximately 10 kg)

Motor meets USCG Electrical Standards (Title 33, Chapter 1, Part 183; Subpart 1) for **IGNITION PROTECTION** on gasoline powered vessels.

APPLICATIONS

Ideal for Bilge Pumping, Bait Tank, Wash Downs, and General Marine Service.

HEAD CAPACITY TABLE

TOTAL HEAD				1800 RPM	
p.s.i.	kg per sq. cm.	ft. of water	metres of water	GPM	litres per min
4.3	0,3	10	3	11.2	42,4
8.7	0,6	20	6,1	10.5	39,7
13.0	0,9	30	9,1	9.4	35,6
17.3	1,2	40	12,2	8.1	30,7

MOTOR VOLTAGE	AMP DRAW	FUSE SIZE	WIRE SIZE		
			0'-10'	11'-20'	21'-35'
12 Vdc	28.0	30	10	8	6
24 Vdc	14.0	15	16	14	14
32 Vdc	9.5	10	16	16	16

OPERATING INSTRUCTIONS

- INSTALLATION** — Pump may be mounted in any position without loss of efficiency; however, it is suggested that the pump head be down if vertical mounting is desired. The rotation of the motor shaft determines the location of the pump's intake and discharge ports. Refer to Dimensional Drawing.
- DRIVE** — Direct.
- SELF-PRIMING** — Pump will produce a suction lift approaching 10 feet when dry and a lift up to 22 feet when primed. **BE SURE SUCTION LINES ARE AIRTIGHT** or pump will not self-prime.
- RUNNING DRY** — Unit depends on liquid pumped for lubrication. **DO NOT RUN DRY** for more than 30 seconds. Lack of liquid will burn the impeller.
- NOTICE** — Do not pump solvents, thinners, highly concentrated or organic acids. Pump damage may result. If corrosive fluids must be handled, pump life will be prolonged if pump is flushed with water after each use or after each work day.
- PRESSURES** — For continuous operation, do not exceed 40 feet total developed head.
- TEMPERATURE** — Impeller supplied in pump is recommended for liquid temperatures of 45° - 180°F (7.2° - 82.2°C). Optional Nitrile Impeller 50° - 180°F (10° - 82.2°C).
- SPARE PARTS** — To avoid costly shut downs, keep a Jabsco Service Kit on hand.

DIMENSIONAL DRAWING
INCHES (MILLIMETRES)

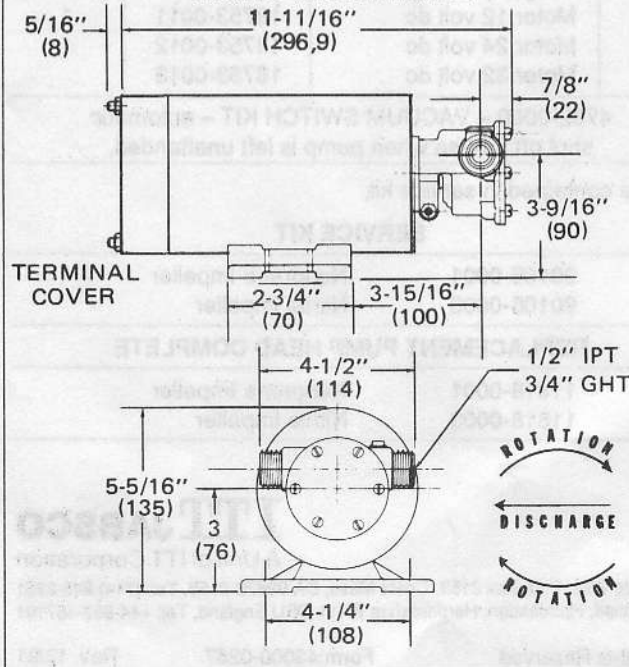

Models 11810-0121, 11810-0241, 11810-0321

EXPLODED VIEW

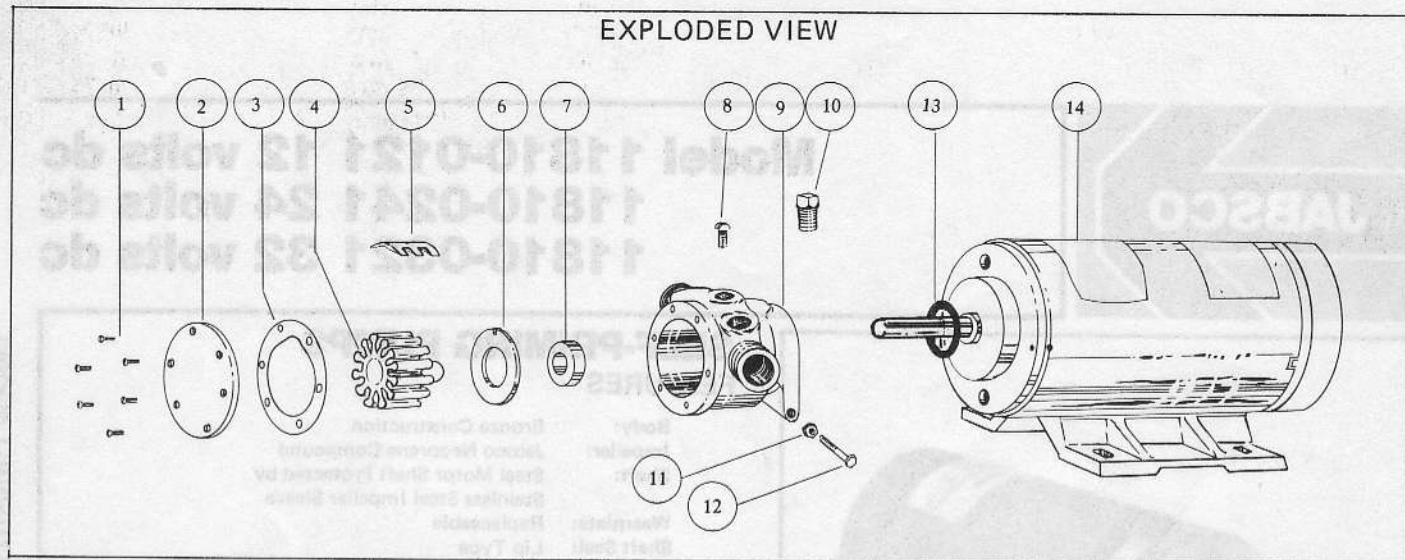

WIRING

It is recommended that a strain relief wire connector be installed in the rear end-bell protective cover to prevent electrical connections from being accidentally pulled loose. Remove the two cover retaining nuts and the protective cover. Select the type of strain relief wire connector to be used and remove the appropriate knock-out. Install the strain relief wire connector in the end-bell cover. Feed the power leads through the wire connector and secure them in place leaving adequate length on the motor side of the cover to attach the leads to the motor terminals.

For proper clock-wise motor rotation attach the positive lead to the motor terminal marked A1 and the negative lead to the terminal marked A2. Re-position the protective cover on the two mounting studs and against the motor end-bell. Secure the cover in place with the two retaining nuts.

If a switch is installed in the positive power lead to control the operation of the pump, it is essential that it has an amperage rating equal to or greater than the recommended fuse size.

SERVICE INSTRUCTIONS

DISASSEMBLY

1. Remove end cover screws, gasket and end cover.
2. Grasp impeller hub with water pump pliers and withdraw from body.
3. Loosen cam screw and remove cam. Clean off sealant.
Remove wearplate with screwdriver or hooked wire.
4. Loosen nut at body clamp. Remove body from motor shaft.
5. Press out seal from motor mounting end of body towards impeller bore.
6. Remove slinger from shaft.

NOTE: Inspect all parts for wear or damage and replace if necessary. When returning to factory for repair, return the pump head only, unless motor replacement is required.

ASSEMBLY

1. Install slinger and position 1/4" from motor boss.
2. Press seal into bore with lip facing toward the impeller bore.
Apply grease to back of seal lip.
3. Install wearplate, aligning slot with dowel pin.
4. Apply sealant to top of cam screw threads. Install cam with cam screw.

5. Install body on motor. Tighten nut at clamp. Do not overtighten or binding of shaft will result.
6. Lubricate impeller bore with water pump grease or equivalent.
7. Lubricate shaft O D with grease, align drive ding in extended impeller insert with flat on shaft and install impeller.
8. Install gasket, end cover and end cover screws.

PARTS LIST

KEY	DESCRIPTION	PART NUMBER	QTY.
1	Screw (End Cover)	91002-0020	6
2	End Cover	11815-0000	1
3*	Gasket	11816-0000	1
4*	Neoprene Impeller	5929-0001	1
	Nitrile Impeller	5929-0003	1
5	Cam	490-0000	1
6	Wearplate	2235-0000	1
7*	Seal (Shaft)	92700-0420	1
8	Screw (Cam)	91003-0010	1
9	Body	11814-0000	1
10	Plug (for vacuum switch hole)	92650-0070	1
11	Nut	91105-0030	1
12	Bolt	91095-0090	1
13	Slinger (O-Ring)	92000-0230	1
14	Motor 12 volt dc	18753-0011	1
	Motor 24 volt dc	18753-0012	
	Motor 32 volt dc	18753-0013	

4732-0000 – VACUUM SWITCH KIT – automatic shut off for use when pump is left unattended.

* Parts contained in service kit.

SERVICE KIT

90105-0001	Neoprene Impeller
90105-0003	Nitrile Impeller

REPLACEMENT PUMP HEAD COMPLETE

11818-0001	Neoprene Impeller
11818-0003	Nitrile Impeller

ITT JABSCO

A Unit of ITT Corporation

1485 Dale Way, P.O. Box 2158, Costa Mesa, CA 92628-2158, Tel: (714) 545-8251
Bingley Road, Hoddesdon, Hertfordshire EN11 0BU England, Tel: +44-992-467191