



BRONZE CLUTCH PUMPS TECHNICAL MANUAL



Jabsco



INDEX

Page 1	Pump Range/Option Guide	Page 14	Parts Service & Installation29870 Series
Page 2	Electromagnetic Clutch Pumps	Page 15	Installation Drawings 50080/50200/50220/50270 Series
Page 3	Manual Clutch Pumps	Page 16	Installation Drawings 51080/51200/51220/51270 Series
Pages 4:5	Performance Curves/Tables	Page 17	Operating/Safety Advice
Pages 6:7	Parts & Service 50080/50200 Series	Page 18	Other Markets
Pages 8:9	Parts & Service 50220/50270 Series		
Pages 10:11	Parts & Service 51080/51200 Series		
Page 12:13 ..	Parts & Service 51220/51270 Series		

FEATURES: BENEFITS

- * **Manual Clutch Pumps have a self adjusting clutch for trouble free operation.**
- * **Manual Clutch Pumps have "double-life" feature to increase clutch life.**
- * **Non-centring one-piece handle helps prevent Manual Clutch handle being partially engaged.**
- * **All clutch pumps have BSP ports - 1", 1½", 2" and 2½" - Port adaptors not required.**
- * **Models are available with Flanged ports (1½", 2" and 2½" Pumps only).**
- * **Most clutch pumps have stainless steel hexagon head metric bolts for end cover retention.**
- * **Most pumps interchangeable with previous range.**
- * **Seal/Impellers and Electric Clutches interchangeable with range replaced.**
- * **080/200 Electromagnetic clutch pumps now more compact than range replaced.**

TYPICAL APPLICATIONS

**Bilge pump out
Deck and anchor wash
Emergency fire fighting
Emergency engine cooling
Ballast transfer**

SIZE	080		200		270		500
Flow @ 1500 RPM	80 L/m		200 L/m		270 L/m		500 L/m
Impeller	Neoprene	Nitrile	Neoprene	Nitrile	Neoprene	Nitrile	Neoprene
Electromagnetic Clutch Pump	50080 - (1" BSP)		50200 - (1½" BSP)		50270 - (2" BSP)		29870 - Flange (& 2½" BSP)
12v dc 2A Section	-2001	-2003	-2011	-2003	-2011	-2013	
24v dc 2A Section	-2101	-2103	-2111	-2103	-2111	-2113	
12v dc 1B Section	-2201	-2203	-2211	-2203	-2211	-2213	
24v dc 1B Section	-2301	-2303	-2311	-2303	-2311	-2313	
12v dc 2B Section							-2001
24v dc 2B Section							-2101
			50220 - 1½" (Flanged)		50270 - 2" (Flanged)		
12v dc 2A Section			-0011	-0003	-0011	-0013	
24v dc 2A Section			-0111	-0103	-0111	-0113	
12v dc 1B Section			-0211	-0203	-0211	-0213	
24v dc 1B Section			-0311	-0303	-0311	-0313	
Optional Available (Distributor Fitted)							
Manual Clutch Pump Suitable for 'A' or 'B' Section Belts	51080 - (1" BSP)		51200 - (1½" BSP)		51270 - (2" BSP)		
	-2001	-2003	-2011	-2003	-2011	-2013	
			51220 - (1½" Flanged)		51270 - (2" Flanged)		
			-0011	-0003	-0011	-0013	
High Pressure Neoprene Impeller	5915-0001		807-1001				
1/2 Cam to reduced flow by 50% approximately	2431 Cam		2551 Cam				
	SP1004-10 Cam Screw		SP1005-05 Cam-Screw				

D.C. CLUTCHES

Inadequate supply voltage at DC terminals (not less than 20% below rated voltage at full load) due to partly discharged battery or voltage loss through long or small size electric wire may cause fuses to blow or pump starting problems. If fuse fails repeatedly, identify and solve the fault. (DO NOT under any circumstances fit a heavier fuse or bridge fuse terminals). Connect black wire to negative (-) battery terminal. Red wire should run via a suitably rated switch and fuse to a positive (+) battery terminal. The pump should be installed where it will always remain dry. Ensure battery capacity is adequate for ALL electrical equipment (pumps, radio, TV, refrigerator, navigational instruments). Observe installation instructions of instruments likely to be affected by close proximity of a magnetic field such as navigational instruments. Electrical installation must take into account the minimum wire size recommended.

12v Clutches need 5 amp fuse with 1.5mm² wiring.
24v Clutches need 2.5 amp fuse with 1.0mm² wiring.

WIRING DIAGRAM

Circuit without Vacuum Switch

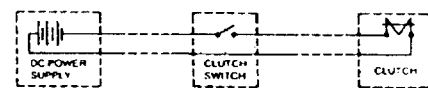

Circuit with Vacuum Switch

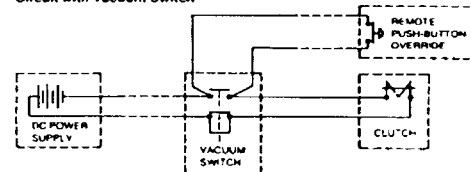

MANUAL CLUTCH PUMPS - DESIGN FEATURES



51080 SERIES

Body	Bronze
Impeller	Jabco neoprene or nitrile compound
Shaft Seal	Lip type
Bearing	Ball
Shaft	Stainless steel 316 S31 to BS970
Wearplate	Replaceable
Pulley	Anodised Aluminium
Ports	1" BSP to BS21 (DIN2999)
Weight	5 kg



51200 SERIES

Body	Bronze
Impeller	Jabco neoprene or nitrile compound
Shaft Seal	Mechanical carbon ceramic
Bearing	Ball
Shaft	Stainless steel 316 S31 to BS970
Wearplate	Replaceable
Pulley	Painted cast iron
Ports	1 1/2" BSP to BS21 (DIN2999)
Weight	8 kg



51220 SERIES

Body	Bronze
Impeller	Jabco neoprene or nitrile compound
Shaft Seal	Mechanical carbon ceramic
Bearing	Ball
Shaft	Stainless steel 316 to BS970
Wearplate	Replaceable
Pulley	Painted cast iron
Bearing Housing	Cast iron painted protective primer
Ports	1 1/2" Flanged
Weight	10 kg



51270 SERIES

Body	Bronze
Impeller	Jabco neoprene or nitrile compound
Shaft Seal	Mechanical carbon ceramic
Bearing	Ball
Shaft	Stainless steel 316 to BS970
Wearplate	Replaceable
Pulley	Painted cast iron
Bearing Housing	Cast iron painted protective primer
Ports	2" BSP to BS21 (DIN2999) Available with 2" Flange
Weight	11 kg

ELECTROMAGNETIC CLUTCH PUMPS - DESIGN FEATURES



50080 SERIES & 50200 SERIES

Body	Bronze
Impeller	Jabsco neoprene or nitrile compound
Shaft Seal	Lip type (50200 Series Mechanical Carbon/Ceramic)
Bearing	Ball
Shaft	Stainless steel 316 S31 to BS970
Wearplate	Replaceable
Pulley	Anodised Aluminium
Ports	1" BSP (50200 Series 1 1/2" BSP) to BS21 (DIN2999)
Weight	5 kg (50200 Series 9.5 kg)



50220 SERIES

Body	Bronze
Impeller	Jabsco neoprene or nitrile compound
Shaft Seal	Mechanical carbon ceramic
Bearing	Ball
Shaft	Stainless steel 316 to BS970
Wearplate	Replaceable
Pulley	Anodised Aluminium
Bearing Housing	Cast iron painted protective primer
Ports	1 1/2" Flange
Weight	11.2 kg



50270 SERIES

Body	Bronze
Impeller	Jabsco neoprene or nitrile compound
Shaft Seal	Mechanical carbon ceramic
Bearing	Ball
Shaft	Stainless steel 316 to BS970
Wearplate	Replaceable
Pulley	Painted cast iron
Bearing Housing	Cast iron painted protective primer
Ports	2" BSP to BS21 (DIN2999) Available with 2" Flange
Weight	12.2 kg



29870 SERIES

Body	Bronze
Impeller	Jabsco neoprene
Shaft Seal	Mechanical carbon ceramic
Bearing	Ball
Shaft	Stainless steel 316 to BS970
Wearplate	Replaceable
Pulley	Painted cast iron
Bearing Housing	Cast iron painted protective primer
Ports	2 1/2" BSP to BS21 (DIN2999) and Flange
Other	Can be purchased without the Clutch
Weight	18 kg

SIZE 080

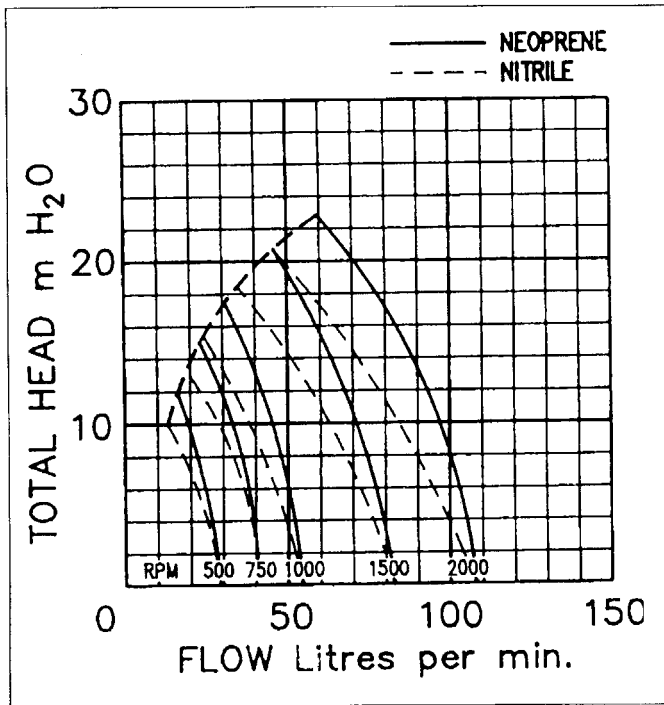

Performance Note Power (watt) figures shown are minimum recommended at pumpshaft.

Total manometric head	500 rpm	750 rpm	1000 rpm	1500 rpm	2000 rpm
	180 watt	180 watt	250 watt	550 watt	750 watt
m/H ₂ O	L/m	L/m	L/m	L/m	L/m
3	26.5	40	53	80	120.5
5	24.5	37.5	57	78	118
9	21	34.5	47.5	74	113.5
12	16.5	29	42.5	68	107
15		23	36	61	99
18			29	52.5	89.5
21				42	78
24					64.5
Suction Bore	25mm	25mm	25mm	25mm	32mm
Temp °C	Metres	Metres	Metres	Metres	Metres
20	7.2	6.9	6.2	4.1	0.5
30	7	6.7	6	3.9	0.3
40	6.6	5.3	5.6	3.5	
50	6	5.7	5	2.9	

Maximum recommended suction head in mH₂O at water temperature 20°C

SIZE 200

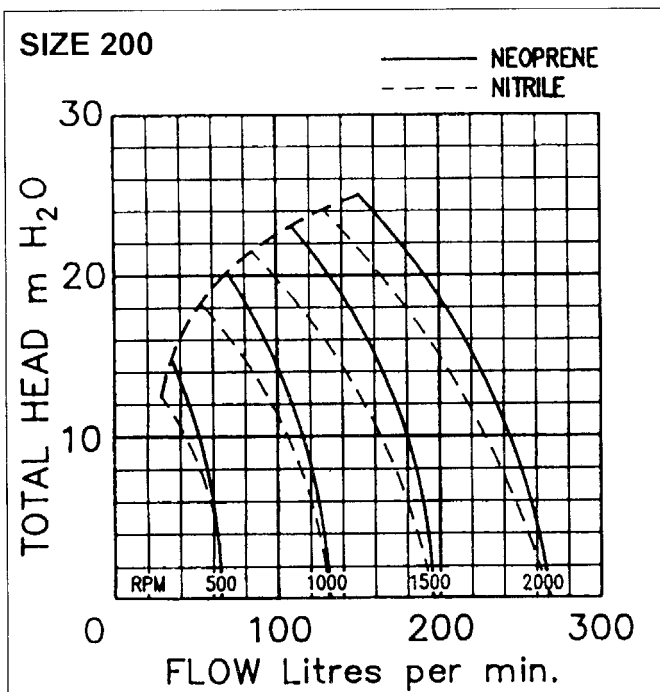

Performance Note Power (watt) figures shown are minimum recommended at pumpshaft.

Total manometric head	500 rpm	1000 rpm	1500 rpm	2000 rpm
	750 watt	1100 watt	1800 watt	
250 watt				
m/H ₂ O	L/m	L/m	L/m	L/m
3	64.5	130	195	261
5	60.5	126	191	256
9	54	118.5	183.5	248
12	45	109	173	236.5
15	33.5	96.5	159	222
18	-	81	142.5	204
21	-	63	123	183
24	-	-	100	159
Suction Bore	40mm	40mm	40mm	40mm
Temp °C	Metres	Metres	Metres	Metres
20	7	5.8	3.6	1
30	6.8	5.6	3.4	0.9
40	6.4	5.2	3	0.5
50	5.8	4.6	2.4	

Maximum recommended suction head in mH₂O at water temperature 20°C

Pump Selection Tables and Graphs show approximate performance for new pumps with neoprene impeller pumping water (specific gravity 1.00) at 20°C, but note that performance can be affected if water temperature and suction head are higher than shown in above table. In doubt consult your local Jabasco distributor or factory for application assistance.

*Minimum nominal recommended bore. Note: Suction Head = Vertical Suction Height + Pipe Losses.

SIZE 270

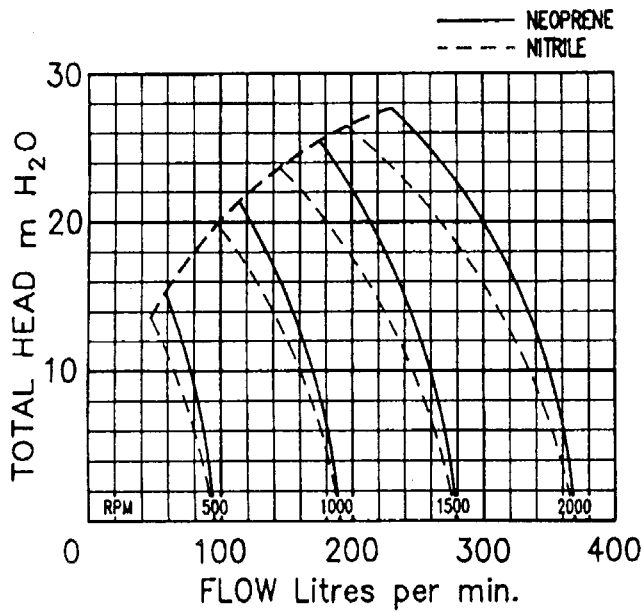

Performance Note Power (watt) figures shown are minimum recommended at pumpshaft.

Total manometric head	500 rpm	750 rpm	1000 rpm	1500 rpm	1750 rpm	2000 rpm
	550 watt	750 watt	1500 watt	1800 watt	2200 watt	3000 watt
m/H ₂ O	L/m	L/m	L/m	L/m	L/m	L/m
3	91	137	183	275	321	368
5	87	133	179	271	317	363
9	81	126	172	263	309	355
12	72	117	162	253	298	343
15	60	105	150	239	284	329
18		90	134	223	267	311
21			116	203	246	290
24				180	223	265
27					196	238
Suction Bore	51mm	51mm	51mm	51mm	51mm	63.5mm
Temp °C	Metres	Metres	Metres	Metres	Metres	Metres
20	7.4	7.4	6.9	4.8	1.9	2.3
30	7.2	7.2	6.7	4.6	1.7	2.1
40	6.8	6.8	6.3	4.2	1.3	1.7
50	6.2	6.2	5.7	3.6	0.7	1.1

Maximum recommended suction head in mH₂O at water temperature 20°C

SIZE 500

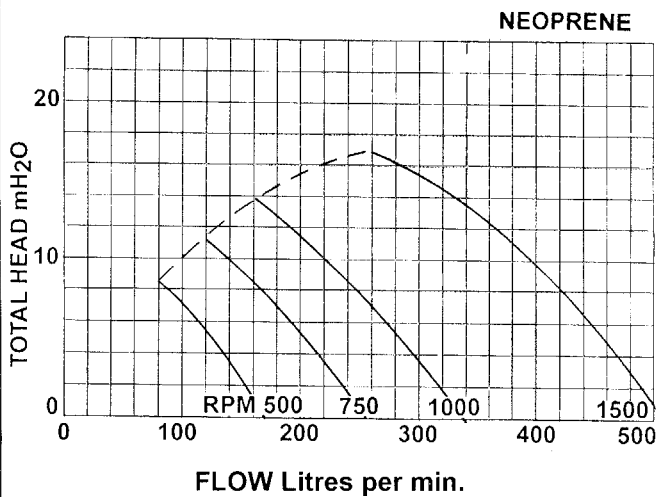

Performance Note Power (watt) figures shown are minimum recommended at pumpshaft.

Total manometric head	500 rpm	750 rpm	1000 rpm	1500 rpm
	1500 watt	2200 watt	2200 watt	4000 watt
5	132	220	303	463
9	79	165	246	402
12	40	127	210	361
15	-	60	145	308
18	-	-	-	250
20	-	-	-	194
Suction Bore	63.5mm	63.5mm	63.5mm	63.5mm
Temp	Metres	Metres	Metres	Metres
20°C	7.5	7.0	6.0	3.5
30°C	7.3	6.8	5.8	3.3
40°C	7.0	6.5	5.5	2.8
50°C	6.5	6.0	5.0	2.3

Maximum recommended suction head in mH₂O at water temperature 20°C

Pump Selection Tables and Graphs show approximate performance for new pumps with neoprene impeller pumping water (specific gravity 1.00) at 20°C, but note that performance can be affected if water temperature and suction head are higher than shown in above table. If in doubt consult your local Jabsco distributor or factory for application assistance.

* Minimum nominal recommended bore. Note: Suction Head = Vertical Suction Height + Pipe Losses.

EXPLODED VIEW

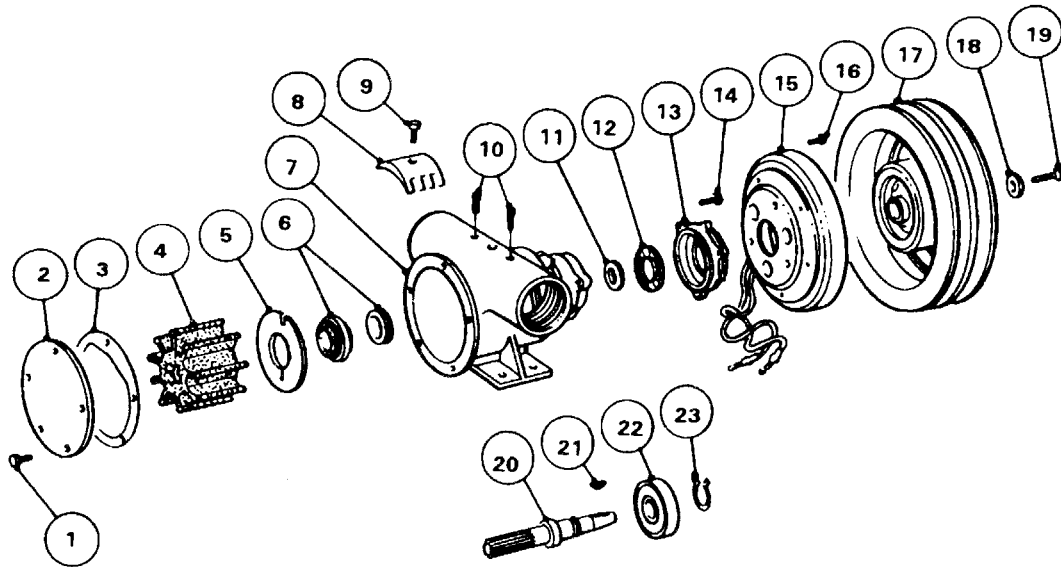

50080 SERIES

KEY	DESCRIPTION	QTY	PART No
1	Endcover Screw*	6	X3001-147F
2	Endcover	1	3993
3	Gasket*	1	890
4	Neoprene Impeller* or Nitrile Impeller**	1	17937-0001/0003
5	Wearplate	1	4156
6	Lip Seal (not shown)*	1	SP2700-1027
7	Body	1	50084-2000
8	Cam	1	934
9	Cam Screw	1	SP1004-09
10	Pipe Plug	2	SP2650-07
11	Slinger	1	3180
12	Inner Bearing Seal	1	SP2700-48
13	(Not Applicable)		
14	(Not Applicable)		
15	Field Coil (12v model)	1	SP2300-0063FC
	Field Coil (24v model)	1	SP2300-0064FC
16	Bolt	3	X3001-176F
17	Pulley (2A)	1	SP2300-0061RA
	Pulley (1B)	1	SP2300-0063RA
18	Screw	1	Supplied with
19	Washer	1	clutch
20	Shaft	1	50087-0000
21	Key	1	SP1401-10
22	Bearing	1	SP2600-06
23	Retaining Ring	1	SP1700-247

Service Kit SK406-0001 contains parts marked*
 Service Kit SK406-0003 contains parts marked* plus ** in place of 17937-0001

50200 SERIES

KEY	DESCRIPTION	QTY	PART No
1	Endcover Screw*	5	X3001-176F
2	Endcover	1	9336
3	Gasket*	1	816
4	Neoprene Impeller* or Nitrile Impeller**	1	17935-0001/836-0003
5	Wearplate	1	2574
6	Seal Assembly*	1	21849
7	Body	1	50204-2000
8	Cam	1	834
9	Cam Screw	1	SP1005-04
10	Pipe Plug	2	SP2650-07
11	Slinger	1	3181
12	Inner Bearing Seal	1	SP2700-50
13	Clutch Adaptor	1	52201-1000
14	Bolts	3	X3001-180F
15	Field Coil (12v model)	1	SP2300-0063FC
	Field Coil (24v model)	1	SP2300-0064FC
16	Bolt	3	X3001-174F
17	Pulley (2A)	1	SP2300-0061RA
	Pulley (1B)	1	SP2300-0063RA
18	Screw	1	Supplied with
19	Washer	1	clutch
20	Shaft	1	50207-0000
21	Key	1	SP1401-10
22	Bearing	1	SP2600-04
23	Retaining ring	1	SP1700-245

Service Kit SK407-0011 contains parts marked*
 Service Kit SK407-0003 contains parts marked* plus ** in place of 17935-0001

Refer to Operating Instructions on page 17.

Inspect all parts for wear or damage and replace if necessary.

50080 SERIES**DIS-ASSEMBLY**

1. Remove end cover screws, end cover and gasket.
2. Remove impeller.
3. Loosen cam screw and remove cam.
4. Remove wearplate.
5. Remove lip seal from body.
6. Remove bolt from end of shaft. Screw 5/8 UNC bolt into the hub of the pulley assembly in order to draw the pulley from the pump shaft.
7. Remove the 3 screws holding the field coil onto the housing adaptor.
8. Remove field coil.
9. Remove fixing bolts and rear housing adaptor from body.
10. Press shaft on impeller drive end to remove shaft and bearing from pump.
11. Remove bearing retaining ring from shaft.
12. Press shaft out of bearing supporting bearing inner race.
13. Remove inner bearing seal if it needs replacing.

ASSEMBLY

1. Press new seal into bearing end of body with lip facing away from bearing bore.
2. Press shaft into bearing supporting inner race of bearing. Fit bearing retaining ring onto shaft.
3. Position slinger in body drain area. Grease seal area of shaft. Push bearing and shaft into body by pressing on outer race of bearing.
4. Fit housing adaptor to pump with 3 bolts.
5. Fit field coil to adaptor using 3 screws. Check that centre bore of field coil fits over boss on the adaptor.
6. Wipe pump shaft to remove any particles and check location of key.
7. Slide pulley assembly onto shaft, lining up with key and secure with retaining bolt.
8. Fit lip seal into body with lip facing into impeller bore.
9. Fit wearplate.
10. Coat cam screw thread, top side and back of cam, with non setting jointing compound and fit into body, securing with the cam screw.
11. Lightly grease impeller bore and fit impeller.
12. Fit end cover and gasket and secure with screws.

50200 SERIES**DIS-ASSEMBLY**

1. Remove end cover screws, end cover and gasket.
2. Remove impeller.
3. Loosen cam screw and remove cam.
4. Remove wearplate.
5. Remove seal assembly from shaft and from body.
6. Remove bolt from end of shaft. Screw 5/8 UNC bolt into the hub of the pulley assembly in order to draw the pulley from the pump shaft.
7. Remove the 3 screws holding the field coil onto the housing adaptor.
8. Remove field coil.
9. Remove fixing bolts and rear housing adaptor from body.
10. Press shaft on impeller drive end to remove shaft and bearing from pump.
11. Remove bearing retaining ring from shaft.
12. Press shaft out of bearing supporting bearing inner race.
13. Remove inner bearing seal if it needs replacing.

ASSEMBLY

1. Press new seal into bearing end of body with lip facing away from bearing bore.
2. Press shaft into bearing supporting inner race of bearing. Fit bearing retaining ring onto shaft.
3. Position slinger in body drain area. Grease seal area of shaft. Push bearing and shaft into body by pressing on outer race of bearing.
4. Fit housing adaptor to pump with 3 bolts.
5. Fit field coil to adaptor using 3 screws. Check that centre bore of field coil fits over boss on the adaptor.
6. Wipe pump shaft to remove any particles and check location of key.
7. Slide pulley assembly onto shaft, lining up with key and secure with retaining bolt.
8. Take new seal seat (cup rubber and seal seat), lightly grease the outside edge of cup rubber and press into cavity in pump body with ceramic facing towards impeller bore. Slide mechanical seal sub assembly over shaft until it engages against ceramic face of stationary seal.
9. Fit wearplate.
10. Coat cam screw threads, top side and back of cam, with non setting jointing compound and fit into body securing with the cam screw.
11. Lightly grease impeller bore and fit impeller.
12. Fit end over and gasket and secure with screws.

Refer to Operating Instructions on page 17.

EXPLODED VIEW

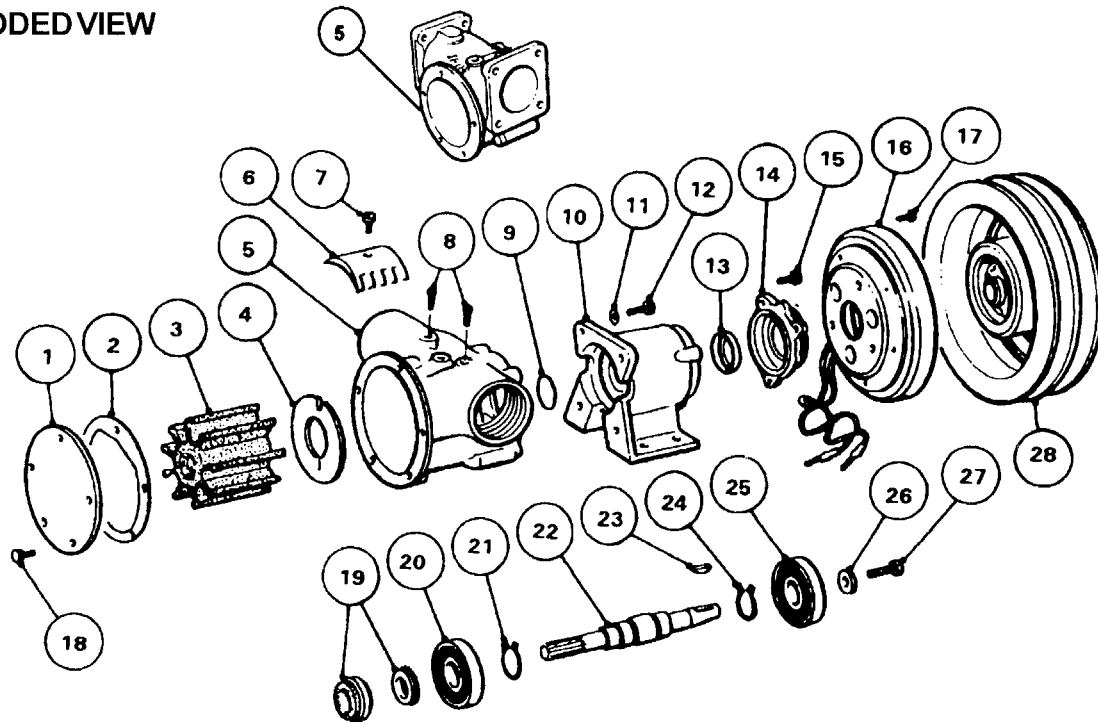

PARTSLIST

KEY	DESCRIPTION	QTY	50220 - SERIES	50270 -0 SERIES	50270-2 SERIES
1	Endcover	1	9336	9336	9336
2	Gasket*	1	816	816	816
3	Neoprene Impeller*	1	17935-0001	21676-0001 or 17936-0001	21676-0001 or 17936-0001
	Nitrile Impeller **	1	836-0003	21676-0003 or 6760-0003	21676-0003 or 6760-0003
4	Wear plate	1	2574	2574	2574
5	Body	1	10634-02 (Flange)	10494-01 (Flange)	50274-2000 (BSP)
6	Cam	1	834	6988	6988
7	Cam Screw	1	SP1005-04	SP1005-04	SP1005-04
8	Pipe Plug	1	SP2650-07	SP2650-07	SP2650-07
9	Slinger	1	X4020-324A	X4020-324A	X4020-324A
10	Bearing Housing	1	50273-0000	50273-0000	50273-0000
11	Washer	4	SP1602-13	SP1602-13	X3081-101C
12	Bolt	4	SP1095-28	SP1095-28	X3001-209C
13	Inner Bearing Seal	1	SP2701-54	SP2701-54	SP2701-54
14	Clutch Adaptor	1	52201-1000	52201-1000	52201-1000
15	Bolt	3	X3001-180F	X3001-180F	X3001-180F
16	Field Coil (12v)	1	SP2300-0063FC	SP2300-0063FC	SP2300-0063FC
	Field Coil (24v)	1	SP2300-0064FC	SP2300-0064FC	SP2300-0064FC
17	Screw***	3	X3001-176F	X3001-176F	X3001-176F
18	Endcover Screws *	5	SP1095-0640	SP1095-0640	X3001-176F
19	Seal Assembly *	1	21849	21849	21849
20	Bearing	1	SP2601-0458	SP2601-0458	SP2601-0458
21	Retaining Ring	1	Y5026-08	Y5026-08	Y5026-08
22	Shaft	1	50227-0000	50277-0000	50277-0000
23	Key	1	SP1401-10	SP1401-10	SP1401-10
24	Retaining Ring	1	Y5026-08	Y5026-08	Y5026-08
25	Bearing	1	SP2601-0458	SP2601-0458	SP2601-0458
26	Washer***	1	Supplied with Clutch	Supplied with Clutch	Supplied with Clutch
27	Screw***	1	Supplied with Clutch	Supplied with Clutch	Supplied with Clutch
28	Pulley (2A)	1	SP2300-0061RA	SP2300-0061RA	SP2300-0061RA
	Pulley (1B)	1	SP2300-0063RA	SP2300-0063RA	SP2300-0063RA

*** Supplied with Key 28

50220 - SERIES

Service Kit SK407-0011
Service Kit SK407-0003

50270 - SERIES

Service Kit SK408-0011
Service Kit SK408-0013

All Service Kits contain parts marked*, plus ** in place of Neoprene Impeller.

Port Adaptors (Optional Extra)

Series	Kit No.	Description
50220	K1-01	2" I/D Hose
	K1-200	1-1/2" BSP
	K1	1-1/2" NPT

Port Adaptors (Optional Extra)

Series	Kit No.	Description
50270-0	K2-01	2-1/2" I/D Hose
	K2-200	2" BSP
	K2	2" NPT

Refer to Operating Instructions on page 17.

Inspect all parts for wear or damage and replace if necessary.

50270 SERIES

DIS-ASSEMBLY

1. Remove end cover screws, end cover and gasket.
2. Remove impeller.
3. Loosen cam screw and remove cam.
4. Remove wearplate.
5. Remove bolt from end of shaft. Screw $\frac{5}{8}$ UNC screw into the hub of the pulley assembly in order to draw the pulley from the pump shaft.
6. Remove 3 bolts holding the field coil onto the housing adaptor.
7. Remove field coil.
8. Remove 3 fixing bolts and rear adaptor housing from bearing housing.
9. Remove bolts from bearing housing to body and remove body from bearing housing.
10. Remove seal assembly from body.
11. Press shaft on impeller drive end to remove shaft and bearings from bearing housing.
12. Press shaft out of bearings supporting inner race of bearing. Remove retaining rings from shaft if necessary.
13. Remove inner bearing seal if it needs replacing.

ASSEMBLY

1. Press new seal into bearing housing with lip facing away from bearing bore.
2. Fit retaining rings onto shaft and press on bearings.
3. Grease seal area of shaft, push bearings and shaft into bearing housing by pressing on outer race of bearings.
4. Fit adaptor housing to bearing housing, secure with 3 bolts.
5. Fit field coil to adaptor using 3 bolts. Check that centre bore of field coil fits over boss on adaptor.
6. Wipe pump shaft to remove any particles and check location of key. Slide pulley assembly onto shaft, lining with key and secure with retaining bolt.
7. Place slinger on shaft.
8. Fit pump body to bearing housing securing with 4 bolts.
9. Take new seal seat (cup rubber and seal seat), lightly grease the outside edge of cup rubber and press into cavity in pump body with ceramic facing towards impeller bore.
10. Slide mechanical seal sub assembly over shaft until it engages against ceramic face of stationary seal.
11. Fit wearplate.
12. Coat cam screw threads, top side and back of cam, with non setting jointing compound and fit into body, securing with the cam screws.
13. Lightly grease impeller bore and fit impeller.
14. Fit end cover and gasket, and secure with screws.

EXPLODED VIEW

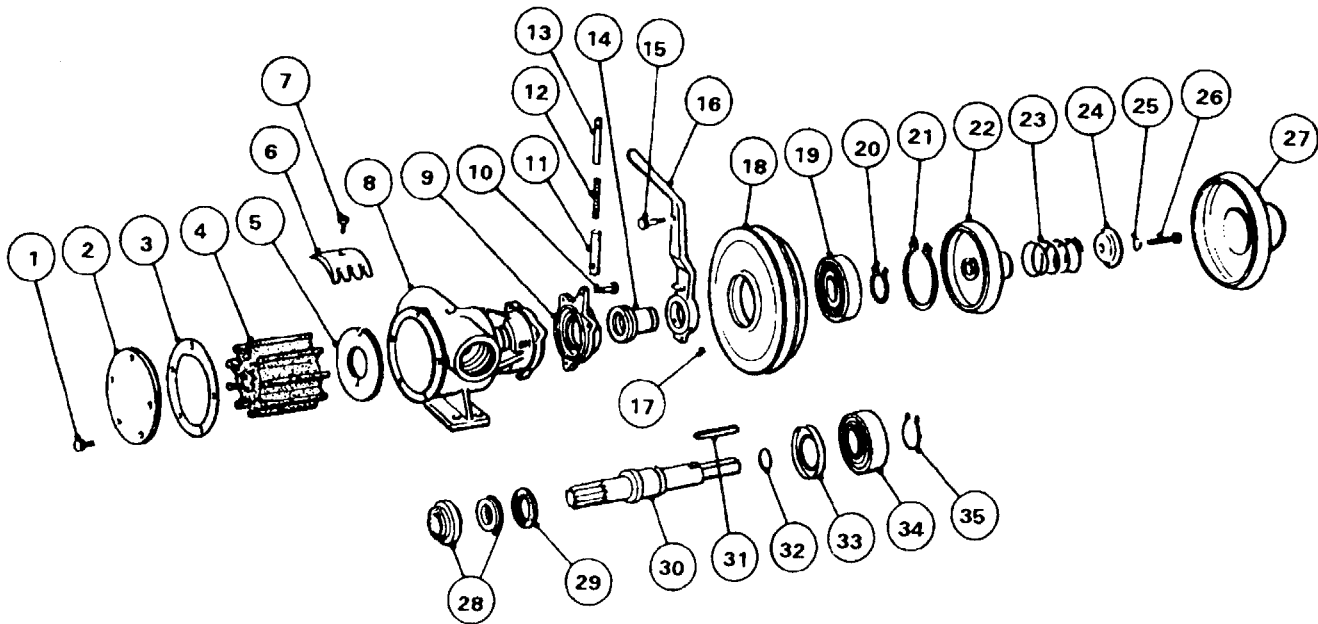

51080 SERIES

KEY	DESCRIPTION	QTY	PARTNUMBER
1	Endcover Screws*	6	X3001-147F
2	Endcover	1	3993
3	Gasket*	1	890
4	Neoprene Impeller* or Nitrile Impeller**	1	17937-0001 17937-0003
5	Wearplate	1	4156
6	Cam	1	934
7	Cam Screw	1	SP1004-09
8	Body	1	50084-2100
9	Engaging Mech/Housing	1	51081-0000
10	Bolt	3	X3001-178F
11	Guide Tube Outer	1	51089-0000
12	Spring	1	51093-0000
13	Guide Tube Inner	1	51088-0000
14	Engaging Mech/Sleeve	1	51082-0000
15	Retaining Bolt	1	51094-0000
16	Handle	1	51083-0000
17	Grub Screw	2	X3009-145F
18	Pulley	1	51084-0000
19	Bearing	1	SP2600-11
20	Retaining Ring	1	SP1700-137
21	Retaining Ring	1	SP1700-245
22	Clutch Cone	1	51085-0000
23	Spring	1	X5250-001
24	Spring Retainer	1	51086-0000
25	Spring Washer	1	X3081-101C
26	Screw	1	X3001-211F
27	Cover	1	51092-0000
28	Lip Seal (not illustrated)	1	SP2700-1027
29	Slinger	1	3180
30	Shaft	1	51087-0000
31	Key	1	X4000-209A
32	Shim	1	51091-0000
33	Inner Bearing Seal	1	SP2700-48
34	Bearing	1	SP2600-06
35	Retaining Ring	1	SP1700-247

Service Kit SK406-0001 contains parts marked*
Service Kit SK406-0003 contains parts marked* plus ** in place of Neoprene Impeller.

51200 SERIES

KEY	DESCRIPTION	QTY	PARTNUMBER
1	Endcover Screws*	5	X3001-176F
2	Endcover	1	9336
3	Gasket*	1	816
4	Neoprene Impeller* Nitrile Impeller**	1	17935-0001 836-0003
5	Wearplate	1	2574
6	Cam	1	834
7	Cam Screw	1	SP1005-04
8	Body	1	50204-2100
9	Engaging Mech/Housing	1	51201-0000
10	Bolt	3	X3001-180F
11	Guide Tube Outer	1	51089-0000
12	Spring	1	51213-0000
13	Guide Tube Inner	1	51088-0000
14	Engaging Mech/Sleeve	1	51202-0000
15	Retaining Bolt	1	51094-0000
16	Handle	1	51203-0000
17	Grub Screw	2	X3009-172F
18	Pulley	1	51204-0000
19	Bearing	1	SP2600-09
20	Retaining Ring	1	SP1700-137
21	Retaining Ring	1	SP1700-245
22	Clutch Cone	1	51205-0000
23	Spring	1	X5250-002
24	Spring Retainer	1	51206-0000
25	Spring Washer	1	X3081-101C
26	Screw	1	X3001-213F
27	Cover	1	51212-0000
28	Seal Assembly*	1	21849
29	Slinger	1	3181
30	Shaft	1	51207-0000
31	Key	1	X4000-270A
32	Shim	1	51211-0000
33	Inner Bearing Seal	1	SP2700-50
34	Bearing	1	SP2600-04
35	Retaining Ring	1	SP1700-245

Service Kit SK407-0011 contains parts marked*
Service Kit SK407-0003 contains parts marked* plus ** in place of Neoprene Impeller.

Refer to Operating Instructions on page 17.

Inspect all parts for wear or damage and replace if necessary.

DIS-ASSEMBLY-CLUTCH

1. Remove snap-on cover.
2. Unscrew spring retaining bolt at end of shaft. Remove retainer, spring and clutch cone.
Note: Bolt is assembled with Loctite.
3. Remove one retaining bolt from guide tube assembly.
4. Unscrew bolts holding engaging mechanism housing to body. Remove complete clutch assembly including pulley and engaging mechanism from pump.
5. Remove key and shim from shaft.
6. To break down handle, pulley and engaging mechanism remove small retaining ring at bearing, support pulley press engaging mechanism sleeve through bearing in handle and remove handle from engaging mechanism.
7. If pulley bearing requires renewing, remove retaining from pulley and push out bearing.

DIS-ASSEMBLY - PUMP

1. Remove end cover screws, end cover and gasket.
2. Remove impeller.
3. Loosen cam screw and remove cam.
4. Remove wearplate.
5. Remove seal assembly, (Lip seal - 51080).
6. Press shaft on impeller drive end to remove shaft and from pump.
7. Remove bearing retaining ring from shaft.
8. Press shaft out of bearing supporting bearing inner.
9. Remove inner bearing seal if it needs replacing.

ASSEMBLY PUMP

1. Press new seal into bearing end of body with lip facing away from bearing bore.
2. Press shaft into bearing supporting inner race of bearing. Fit bearing retaining ring onto shaft.
3. Position slinger in body drain area. Grease seal area of shaft. Push bearing and shaft into body by pressing on outer race of bearing.
4. MODEL 51080.
Fit lip seal into body with lip facing into impeller bore.
MODEL 51200
Take new seal seat (cup rubber and seal seat), lightly grease the outside edge of cup rubber and press into cavity in pump body with ceramic facing towards impeller bore. Slide mechanical seal sub assembly over shaft until it engages against ceramic face of stationary seal.
5. Fit wearplate.
6. Coat cam screw thread, top side and back of cam, with non setting jointing compound and fit into body, securing with the cam screw.
7. Lightly grease impeller bore and fit impeller.
8. Fit end cover and gasket and secure with screws.

ASSEMBLY-CLUTCH

1. Screw engaging mech/sleeve into housing approximately 1 turn. Fit handle over sleeve and set 0.25mm clearance between housing and handle, when in the dis-engaged position, by screwing sleeve in or out as required. Lock handle on sleeve with grub screws.
Note: Lubricate thread with ANTI-SCUFFING PASTE.
2. Re-fit bearing and retaining ring into pulley. While supporting clutch mech/sleeve press pulley bearing assembly onto sleeve hard up against handle.
3. Fit pulley/handle/engaging mech. assembly to pump with 3 bolts.
4. Fit guide tube mechanism to handle and to engaging mech housing.
5. Fit shim and key onto shaft.
6. Fit clutch cone, spring and spring retainer and secure with bolt. Tighten bolt until retainer is clamped against shaft.
Notes: Lubricate between shaft and clutch cone with ANTI-SCUFFING PASTE. Assemble screw with Loctite (nut lock).
7. Re-fit snap-on cover.

ADJUSTMENT-CLUTCH

When new, the clutch will begin to engage approx. half way between the 'OFF' and 'ON' position i.e. when handle is near to the vertical position. As wear takes place the engaging position will move towards the 'ON' position. When there is little movement left between the engaging point and the 'ON' stop the clutch can be adjusted as follows:

1. When handle in the 'OFF' position remove snap on cover.
2. Unscrew spring retaining bolt at end of shaft. Remove retainer spring, clutch cone and key.
Note: Bolt is assembled with Loctite Nut Lock.
3. Remove shim and re-assemble key, clutch cone, spring, retainer, screw and cover.
Note: Removal of shim will restore engaging point to its original position. Once shim has been removed no further adjustment is possible and clutch cone, and possibly pulley will need to be replaced.

Refer to Operating Instructions on page 17.

EXPLODED VIEW

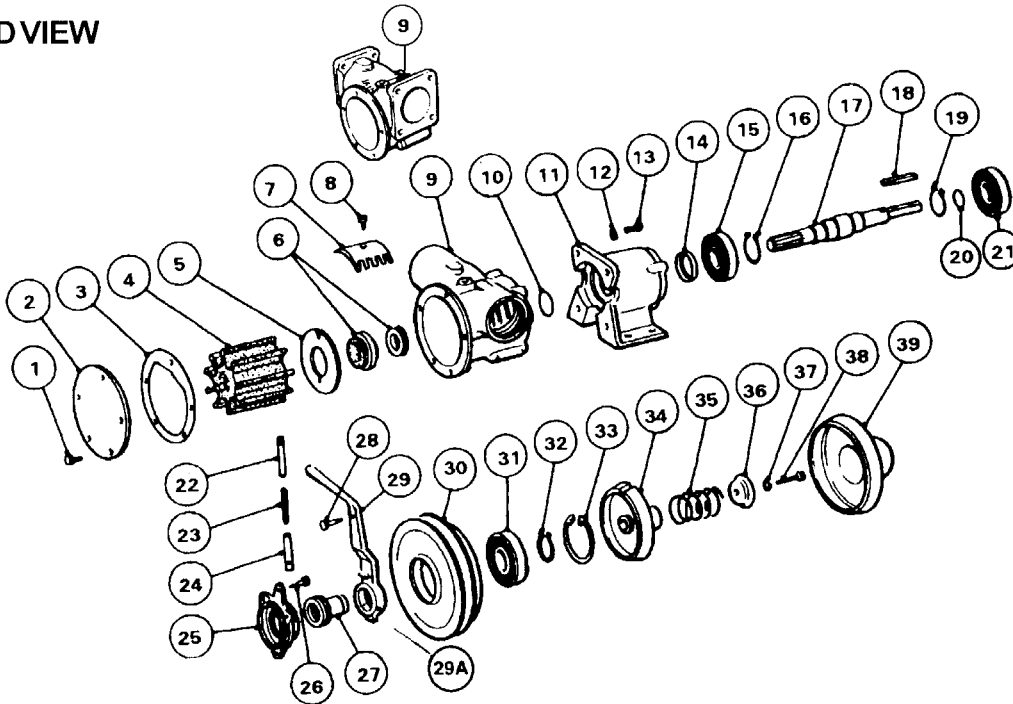

PARTS LIST

KEY	DESCRIPTION	QTY	Model 51220- Part No.	Model 51270-0 Part No.	Model 51270-2 Part No.
1	Endcover Screws*	5	SP1095-0640	SP1095-0640	X3001-176F
2	Endcover	1	9336	9336	9336
3	Gasket *	1	816	816	816
4	Neoprene Impeller *	1	17935-0001	21676-0001 or 17936-0001	21676-0001 or 17936-0001
	Nitrile Impeller **	1	836-0003	21676-0003 or 6760-0003	21676-0003 or 6760-0003
5	Wearplate	1	2574	2574	2574
6	Seal Assembly *	1	21849	21849	21849
7	Cam	1	834	6988	6988
8	Cam Screw	1	SP1005-04	SP1005-04	SP1005-04
9	Body	1	10634 (Flange)	10494 (Flange)	50274-0000 (BSP)
10	Slinger	1	X4020-324A	X4020-324A	X4020-324A
11	Bearing Housing	1	50273-0000	50273-0000	50273-0000
12	Washer	4	SP1602-13	SP1602-13	X3081-101C
13	Bolt	4	SP1095-28	SP1095-28	X3001-209C
14	Inner Bearing Seal	1	SP2701-54	SP2701-54	SP2701-54
15	Bearing	1	SP2601-0458	SP2601-0458	SP2601-0458
16	Retaining Ring	1	Y5026-06	Y5026-06	Y5026-06
17	Shaft	1	51227-0000	51277-0000	51277-0000
18	Key	1	X4000-270A	X4000-270A	X4000-270A
19	Retaining Ring	1	Y5026-06	Y5026-06	Y5026-06
20	Shim	1	51211-0000	51211-0000	51211-0000
21	Bearing	1	SP2601-0458	SP2601-0458	SP2601-0458
22	Guide Tube Outer	1	51089-0000	51089-0000	51089-0000
23	Spring	1	51213-0000	51213-0000	51213-0000
24	Guide Tube Inner	1	51088-0000	51088-0000	51088-0000
25	Engaging Mech / Housing	1	51201-0000	51201-0000	51201-0000
26	Screw	3	X3001-180F	X3001-180F	X3001-180F
27	Engaging Mech/Sleeve	1	51202-0000	51202-0000	51202-0000
28	Retaining Bolt	1	51094-0000	51094-0000	51094-0000
29	Handle	1	51203-0000	51203-0000	51203-0000
29A	Grub Screw (not shown)	2	X3009-172F	X3009-172F	X3009-172F
30	Pulley	1	51204-0000	51204-0000	51204-0000
31	Bearing	1	SP2600-09	SP2600-09	SP2600-09
32	Retaining Ring	1	SP1700-137	SP1700-137	SP1700-137
33	Retaining Ring	1	SP1700-283	SP1700-283	SP1700-283
34	Clutch Cone	1	51205-0000	51205-0000	51205-0000
35	Spring	1	X5250-002	X5250-002	X5250-002
36	Spring Retainer	1	51206-0000	51206-0000	51206-0000
37	Spring Washer	1	X3081-101C	X3081-101C	X3081-101C
38	Screw	1	X3001-213F	X3001-213F	X3001-213F
39	Cover	1	51212-0000	51212-0000	51212-0000

51220 - SERIES

Service Kit SK407-0011
Service Kit SK407-0003

51270 - SERIES

Service Kit SK408-0011
Service Kit SK408-0013

All Service Kits contain
parts marked*, plus **
in place of Neoprene Impeller.

Port Adaptors (Optional Extra)

Series	Kit No.	Description
51220	K1-01	2" I/D Hose
	K1-200	1-1/2" BSP
	K1	1-1/2" NPT

Port Adaptors (Optional Extra)

Series	Kit No.	Description
51270	K2-01	2-1/2" I/D Hose
	K2-200	2" BSP
	K2	2" NPT

Refer to Operating Instructions on page 17.

Inspect all parts for wear or damage and replace if necessary.

DIS-ASSEMBLY-CLUTCH

1. Remove snap-on cover.
2. Unscrew spring retaining bolt at end of shaft. Remove retainer, spring and clutch cone.
Note: Bolt is assembled with Loctite.
3. Remove one retaining bolt from guide tube assembly.
4. Unscrew bolts holding engaging mechanism housing to body. Remove complete clutch assembly handle, pulley and engaging mechanism from pump.
5. Remove key and shim from shaft.
6. To break down handle, pulley and engaging mechanism assembly remove small retaining ring at bearing, support pulley and press engaging sleeve through bearing. Loosen screws in handle and remove handle from engaging mechanism.
7. If pulley bearing requires renewing, remove retaining ring from pulley and push out bearing.

DIS-ASSEMBLY - PUMP

1. Remove end cover screw, end cover and gasket.
2. Remove impeller.
3. Loosen cam screw and remove cam.
4. Remove wearplate.
5. Remove bolts from bearing housing to body. Remove pump from bearing housing.
6. Remove seal assembly from body.
7. Press shaft on impeller drive end to remove shaft and bearing from pump.
8. Press shaft out of bearing supporting bearing inner race.
9. Remove inner bearing seal if it needs replacing.

ASSEMBLY - PUMP

1. Press new seal into bearing housing with lip facing away from bearing bore.
2. Fit retaining rings onto shaft and press on bearings.
3. Grease seal area of shaft, push bearings and shaft into bearing housing by pressing on outer race of bearing.
4. Place slinger on shaft.
5. Fit pump body to bearing housing securing with 4 bolts.
6. Take new seal (cup rubber and seal seat), lightly grease the outside edge of cup rubber and press into cavity in pump body with ceramic facing towards impeller bore. Slide mechanical seal sub assembly over shaft until it engages against ceramic face of stationary seal.
7. Fit wearplate.
8. Coat cam screw thread, top side and back of cam, with non setting jointing compound and fit into body, securing with the cam screw.
9. Lightly grease impeller bore and fit impeller.
10. Fit end cover and gasket and secure with screws.

ASSEMBLY - CLUTCH

1. Screw engaging mech/sleeve into housing approximately 1 turn. Fit handle over sleeve and set 0.5mm clearance between housing and handle, when in the dis-engaged position, by screwing sleeve in or out as required. Lock handle on sleeve with grub screws.
Note: Lubricate threads with ANTI-SCUFFING PASTE.
2. Re-fit bearing and retaining ring into pulley. While supporting clutch mech/sleeve press pulley bearing assembly onto sleeve hard up against handle.
3. Fit pulley/handle/engaging mech assembly to pump with 3 bolts.
4. Fit guide tube mechanism to handle and to engaging mech housing.
5. Fit shim and key onto shaft.
6. Fit clutch cone, spring and spring retainer and secure with bolt. Tighten bolt until retainer is clamped against shaft. Notes: Lubricate between shaft and clutch cone with ANTI-SCUFFING PASTE. Assemble screw with Loctite (nut lock).
7. Re-fit snap on cover.

ADJUSTMENT-CLUTCH

When new, the clutch will begin to engage approx. half way between the 'OFF' and 'ON' position i.e. when handle is near to the vertical position. As wear takes place the engaging position will move towards the 'ON' position. When there is little movement left between the engaging point and the 'ON' stop, the clutch can be adjusted as follows:

1. With handle in the 'OFF' position remove snap on cover.
2. Unscrew spring retaining bolt at end of shaft. Remove retainer, spring, clutch cone and key.
Note: Bolt is assembled with Loctite (nut lock).
3. Remove shim and re-assemble key, clutch cone, spring, retainer, screw and cover.
Note: Removal of shim will restore engaging point to its original position. Once shim has been removed no further adjustment is possible, and clutch cone, and possibly pulley will need to be replaced.

Refer to Operating Instructions on page 17.

EXPLODED VIEW

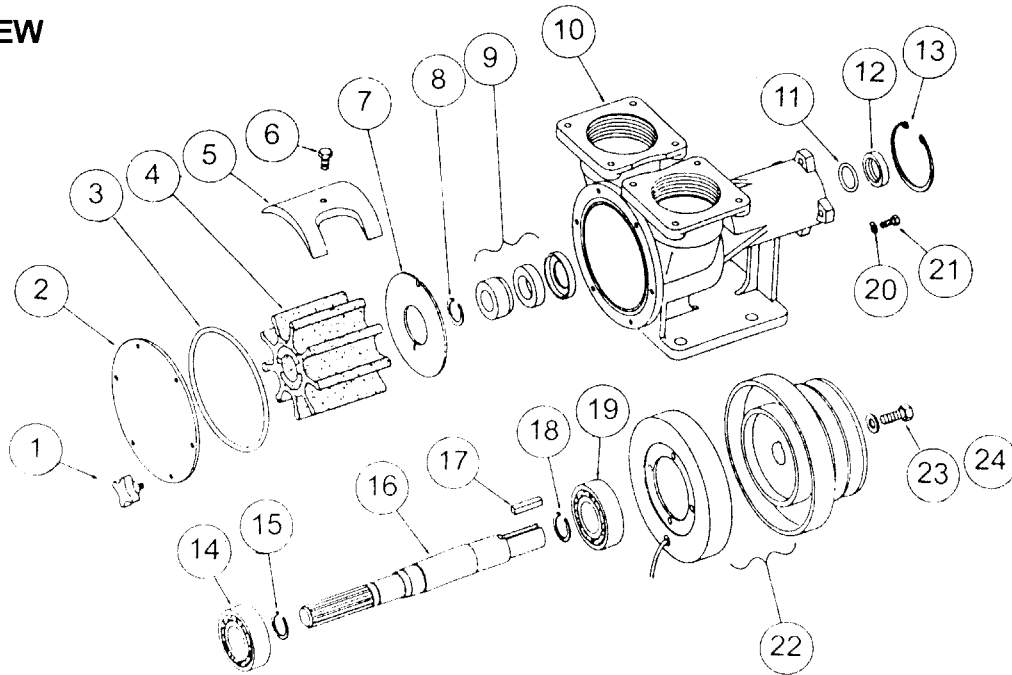

PARTS LIST

KEY	DESCRIPTION	QTY	Part No.
1	End Cover Screws	4	X5255-002
2	End Cover	1	29865-0000
3	O'-Ring*	1	X4020-424A
4	Neoprene Impeller*	1	17240-0001B
5	Cam	1	29863-0100
6	Cam Screw	1	X3001-207F
7	Wearplate	1	29866-0000
8	Retaining Ring	1	SP1700-3015
9	Seal Assembly*	1	21849
10	Body	1	29864-2000
11	Slinger	1	X4020-324A
12	Outer Bearing Seal	1	SP2701-54
13	Retaining Ring	1	SP1701-244
14	Bearing	1	SP2601-0458
15	Retaining Ring	1	SP1700-3014
16	Shaft	1	29867-0000
17	Key	1	X5271-002
18	Retaining Ring	1	SP1700-3014
19	Bearing	1	SP2601-0458
20	Washer	4	X3081-091F
21	Bolt	4	X3001-180F
22	Clutch Assembly 12V	1	X5274-001
22	Clutch Assembly 24V	1	X5274-002
23	Spring Washer	1	X3081-111F
24	Screw	1	X3001-242F
Service Kit contains items marked *			SK412-0001

Inspect all parts for wear or damage and replace if necessary.

DIS-ASSEMBLY

1. Remove end cover screws, end cover and O-ring.
2. Remove impeller.
3. Loosen cam screw and remove cam.
4. Remove wearplate.
5. Remove screw from end of shaft. Screw $\frac{5}{8}$ UNC screw into the hub of the pulley assembly in order to draw the pulley from the pump shaft.
6. Remove 4 bolts and washers holding the field coil onto the housing adaptor.
7. Remove field coil.
8. Remove seal retaining ring from shaft.
9. Remove seal assembly from body and slinger.
10. Remove retaining ring from body.
11. Press shaft on impeller drive end to remove shaft and bearings from bearing housing.
12. Press shaft out of bearings supporting inner race of bearing. Remove retaining rings from shaft if necessary.
13. Remove pump inner bearing seal if it needs replacing.

ASSEMBLY

1. If removed press inner bearing seal into bearing housing with lip facing away from bearing bore.
2. Fit retaining rings onto shaft and press on bearings.
3. Grease seal area of shaft, push bearings and shaft into bearing housing by pressing on outer race of bearings.
4. Fit retaining ring.
5. Fit field coil to adaptor using 4 bolts and washers.
6. Wipe pump shaft to remove any particles and check location of key. Slide pulley assembly onto shaft, lining with key and secure with retaining bolt.
7. Place slinger on shaft.
8. Take new seal seat (cup rubber and seal seat), lightly grease the outside edge of cup rubber and press into cavity in pump body with ceramic facing towards impeller bore.
9. Slide mechanical seal sub assembly over shaft until it engages against ceramic face of stationary seal.
10. Fit retaining ring.
11. Fit wearplate.
12. Coat cam screw threads, top side and back of cam, with non setting jointing compound and fit into body, securing with cam screw.
13. Lightly grease impeller bore and fit impeller.
14. Fit O-ring and end cover and secure with screws.

INSTALLATION DIAGRAM

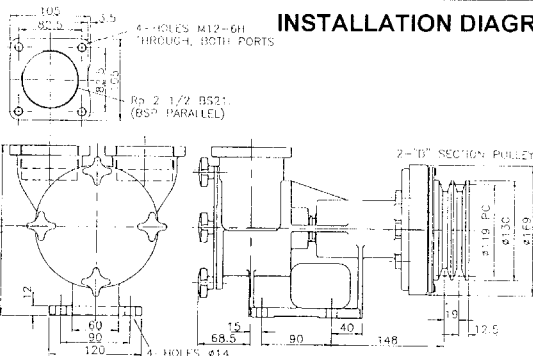

Refer to Operating Instructions on page 17.

50200 SERIES

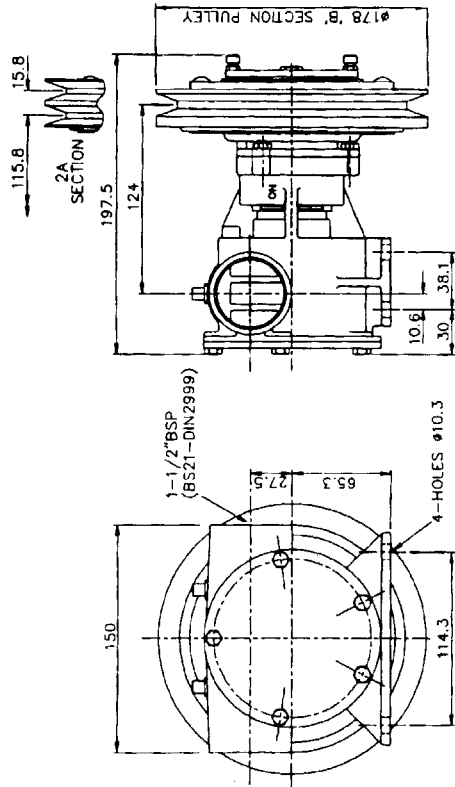

50080 SERIES

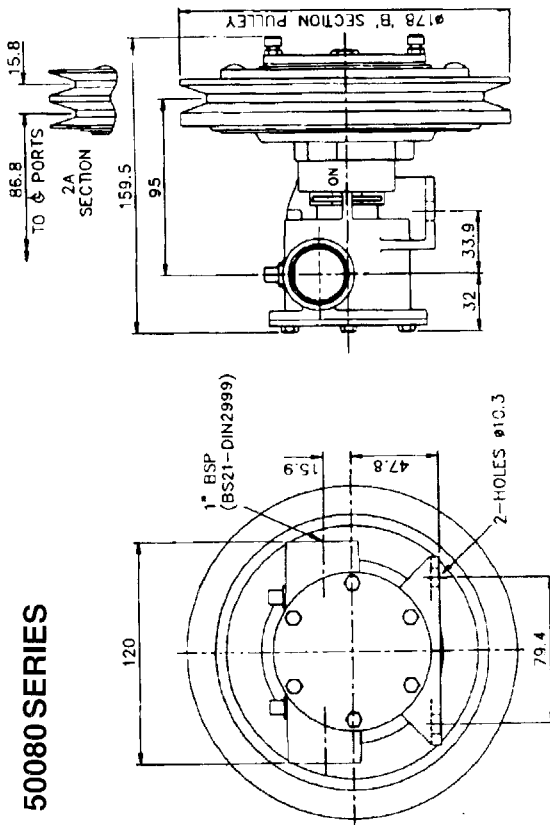

50270 SERIES

PORT TAPPING (TYP)
4-HOLES 3/8"-16 UNC 2B
EQUALLY SPACED ON
Ø90.47 ±0.2 PC.

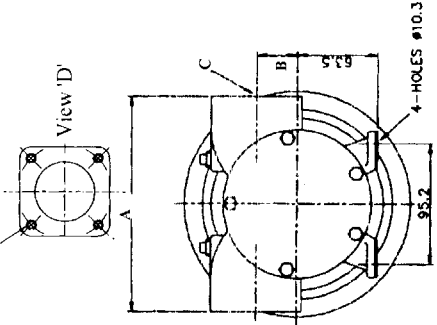

	A	B	C
50270 - 'O' Series	152.4	41.3	See View 'D'
50270 - '2' Series	170	32	2" BSP (BS21 - DIN2999)

50220 SERIES (Flanged Ports)

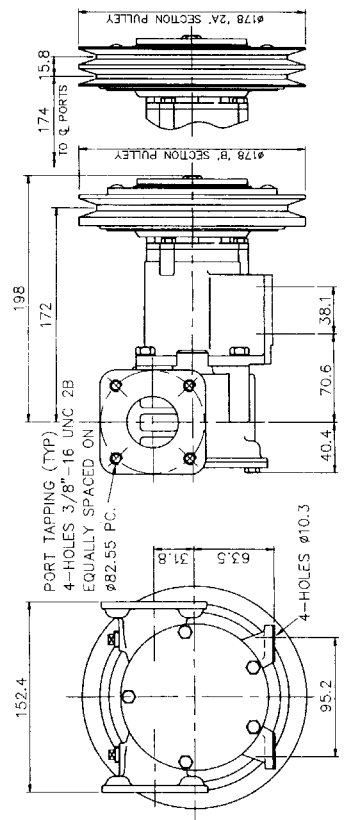

51200 SERIES

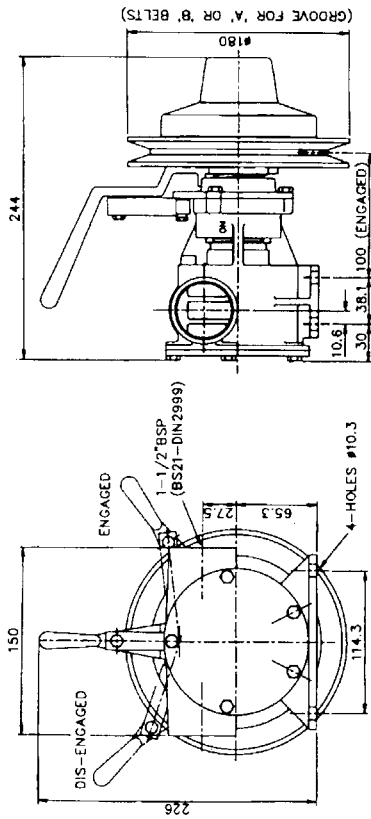

51080 SERIES

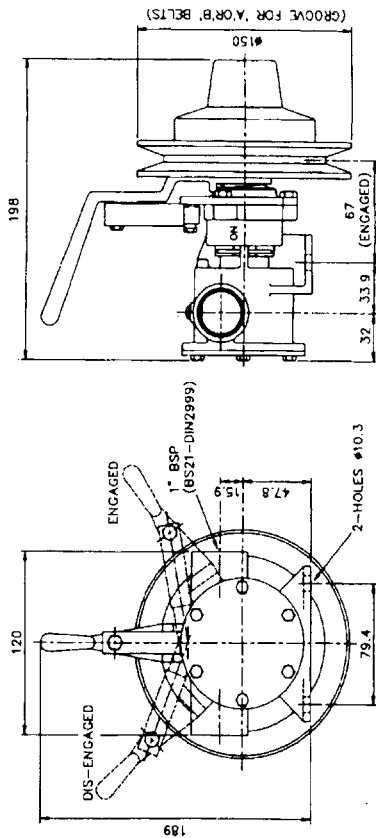

51270 SERIES

PORT TAPPING (TYP)
4 HOLES 3/8" - 16 UNC 2B
EQUALLY SPACED ON
Ø90.47 ±0.2 PC.

	A	B	C
51270 - 'O' Series	152.4	41.3	See View 'D'
51270 - '2' Series	170	32	2" BSP (BS21 - DIN2999)

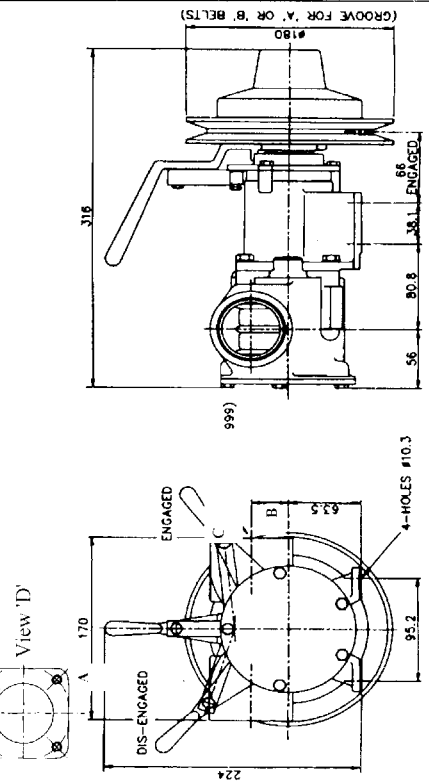

51220 SERIES (Flanged Ports)

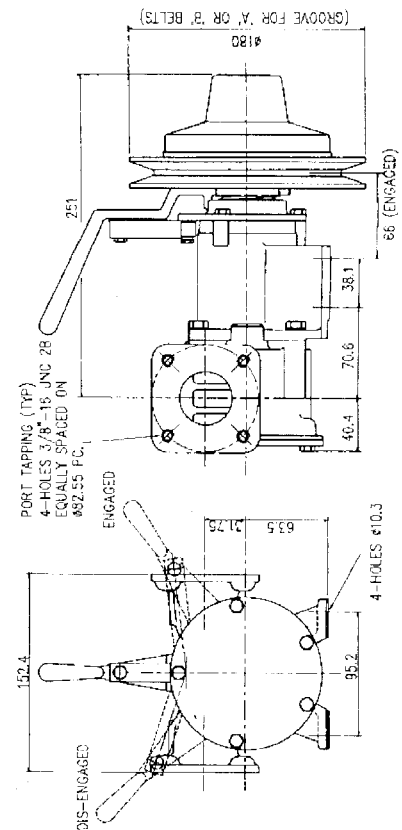

PUMP MAY BE MOUNTED in any position. When installed vertically motor must be above the pump.

THE ROTATION OF THE PUMP SHAFT determines the location of the pump inlet/outlet ports; refer to installation drawing.

BEFORE INSTALLING rotate pump shaft and impeller in the direction of the required operation.

ALL PUMP PIPEWORK must be adequately supported to avoid stress on pump and pump components and consequential leakage.

BELT DRIVEN PUMPS excessive drive belt tension will cause rapid belt wear and may result in premature bearing failure. It should be possible to deflect a correctly tensioned belt between pulleys about 16mm per metre of span by applying finger pressure. Ideally, the contact area should be about 120° but not less than 90°.

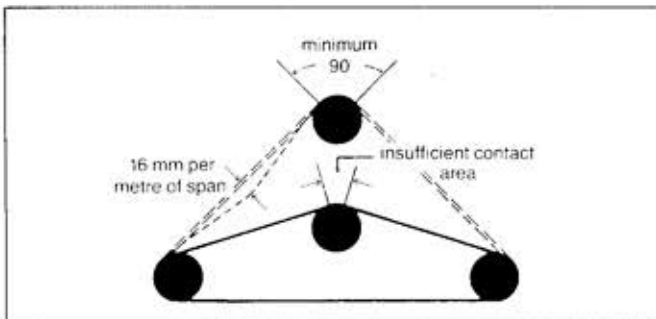

OPERATION

Pump should not be operated above its published performance without referring to distributor.

D.C. CLUTCHES

Inadequate supply voltage at DC terminals (not less than 20% below rated voltage at full load) due to partly discharged battery or voltage loss through long or small size electric wire may cause fuses to blow or pump starting problems. If fuse fails repeatedly, identify and solve the fault. (DO NOT under any circumstances fit a heavier fuse or bridge fuse terminals). Connect black wire or negative (-) battery terminal.

Red wire should run via a suitably rated switch and fuse to a positive (+) battery terminal. The pump should be installed where it will always remain dry. Ensure battery capacity is adequate for ALL electrical equipment (pumps, radio, TV, refrigerator, navigational instruments). Observe installation instructions of instruments likely to be affected by close proximity of a magnetic field such as navigational instruments.

WIRING DIAGRAM

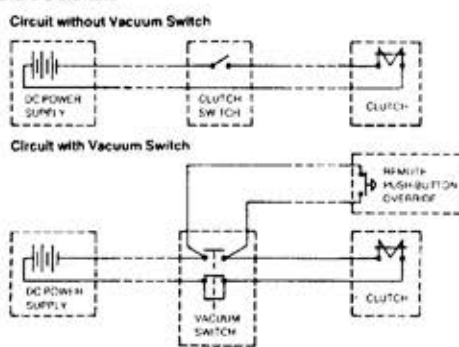

Electrical installation must take into account the minimum wire size recommended.

12v Clutches need 5 amp fuse with 1.5mm² wiring.
24v Clutches need 2.5 amp fuse with 1.0mm² wiring.

TEMPERATURE: Operating range

Neoprene Impellers	4-80°C
Oil Resistant Impellers	10-90°C

PUMPS: are dry self-priming i.e. do not require to be filled with liquid start up.

RUNNING DRY: Unit depends on liquid pumped for lubrication. A dry running period of up to 30 seconds is generally a safe length of time. If pump has not been primed after 30 seconds, stop and check for air leaks in pipework, and impeller, seal or gasket damage.

SAFETY ADVICE

Ensure that all moving parts are adequately guarded to prevent accidental contact. Leakage from mechanical seal or gland could cause hazard. If liquids being pumped are toxic or corrosive, use of a drip tray is recommended.

DO NOT USE for Petrol, Toluene, Benzene or light fraction petroleum products such as solvent, thinners or other liquids with flashpoint below 37°C.

FREEZING Temperatures - do not permit liquid to freeze in pump body. Drain pump by loosening end cover.

IT IS A REQUIREMENT OF COSHH(1988) REGULATIONS THAT THE MANUFACTURER'S INSTRUCTIONS IN THE HANDLING OF HAZARDOUS SUBSTANCES MUST BE OBSERVED AT ALL TIMES.

To conform with the Health and Safety and COSHH Regulations, Jabsco will require that any pump or part of a pump that is returned to this company for repair or examination, or for any reason whatsoever, will be accompanied by a letter stating what the pump/part has been pumping.

If the liquid or product is hazardous or in any way dangerous, this must be stated and the chemical make-up of it must be stated in detail.

Unless this procedure is observed then the unit will not be accepted on our company premises. The only exception to this rule is if the pump returned is new and unused.

Jabsco

USA

Jabsco
20 Icon
Foothill Ranch
CA 92610

Tel : +1 949 859 4945
Fax : +1 949 859 1153

UK

Jabsco
Bingley Road
Hoddesdon
Hertfordshire, EN11 0BU

Tel : +44 (0) 1992 450 145
Fax : +44 (0) 1992 467 132

GERMANY

Jabsco GmbH
Oststraße 28
22844 Norderstedt

Tel : +49 (0) 40 53 53 73 0
Fax : +49 (0) 40 53 53 73 11