



Model 4560-Series 4590-Series 4620-Series

SELF-PRIMING PUMPS

FEATURES

Body:	Bronze Construction
Impeller:	Neoprene or Nitrile
Shaft:	Stainless Steel
Shaft Seal:	Packing Type
Bearings:	Plain
Ports:	Model 4560-Series 1/2" NPT Model 4590-Series 3/4" NPT Model 4620-Series 1" NPT
Weight:	Model 4560-Series 3-3/4 lb (1.7 kg) Model 4590-Series 5 lb (2.3 kg) Model 4620-Series 5-1/4 lb (2.4 kg)



Model 4560-Series,
4590-Series, 4620-Series

Other JABSCO models are also available in bronze, plastic and stainless steel. JABSCO Pureflo® pumps are also available for sanitary applications.

VARIATIONS AVAILABLE

Model	Variation Incorporated
4560-0001	Neoprene Impeller
-0003	Nitrile Impeller
4590-0001	Neoprene Impeller
-0003	Nitrile Impeller
4620-0001	Neoprene Impeller
-0003	Nitrile Impeller

APPLICATIONS

MARINE: Pumping bilges, washdowns, circulating water in bait tanks, utility dockside pump, engine cooling.

INDUSTRIAL: Circulating and transferring, velocity-mixing, pumping machine tool coolants, return spill, sump drainage, chemicals, pharmaceuticals, soap, liquors, ink, dyes, alcohol, various acids, tanning liquors, glycerine, brine, etc.

FARMING: Pumping water for stock, pumping water from shallow wells and cisterns, pumping liquid ballast into tractor tires.

PLUMBING & HOME EMERGENCY USE: Pumping out flooded basements, cesspools, sumps, water heaters and water closets, drains and sinks, draining fishponds and pools.

OPERATING INSTRUCTIONS

1. **INSTALLATION** – Pump may be mounted in any position. Intake and discharge ports are determined by the direction of shaft rotation (refer to Dimensional Drawing). Before installing, turn the pump shaft in the direction of the operating rotation.

2. **DRIVE** – Belt or Direct with flexible coupling.

Belt Drive: Overtight belt load will reduce pump bearing life. Direct Drive is recommended for operating speeds above 1750 RPM.

Direct Drive: Clearance should be left between drive shaft and pump shaft when installing coupling. Always mount and align pump and drive shaft before tightening the coupling set screw.

NOTICE: If the drive pulley or coupling must be pressed on the shaft, remove the end cover and impeller and support the shaft from the impeller end during the press operation. Do not hammer a pulley or coupling on the shaft. Failure to follow the above instructions can damage the pump.

3. **SPEEDS** – 100 RPM to the maximum shown in the performance table. Consult the factory for operation at speeds above those shown. For longer pump life, operate at lowest possible speeds.

4. **SELF-PRIMING** – Primes at low or high speeds. For vertical dry suction lift of 10 feet, a minimum of 800 RPM is required. Pump will produce suction lift up to 22 feet when wetted. **BE SURE SUCTION LINES ARE AIRTIGHT OR PUMP WILL NOT SELF-PRIME.**

5. **RUNNING DRY** – Unit depends on liquid pumped for lubrication. **DO NOT RUN DRY** for more than 30 seconds. Lack of liquid will damage the impeller.
6. **NOTICE** – If pumping light fraction petroleum derivatives, solvents, thinners, highly concentrated or organic acids, consult Jabsco Chemical Resistance Table (which is available upon request from ITT Jabsco) for proper body materials and impeller compounds. If corrosive fluids are handled, pump life will be prolonged if pump is flushed with water after each use or after each work day.
7. **PRESSURES** – Consult Head Capacity Table for recommended maximum for continuous operation. If pressures exceed those shown, consult the factory.
8. **TEMPERATURE** – Neoprene 45°–180°F (7°–82°C) Nitrile 50°–180°F (10°–82°C).
9. **FREEZING WEATHER** – Drain unit by loosening end cover. The following anti-freeze compounds can be used without any adverse effects to the neoprene impeller: Atlas “Permaguard”, DuPont “Zerex” and “Telar”, Dow Chemical “Dowguard” and Olin Mathison “Pyro Permanent”. Most Methyl alcohol (methanol) based antifreeze can be used.

DO NOT USE PETROLEUM BASED ANTI-FREEZE COMPOUNDS OR RUST INHIBITORS.
10. **GASKET** – Use a standard pump part. A thicker gasket will reduce priming ability. A thinner gasket will cause the impeller to bind. Std. gasket 0.010” thick.
11. **GREASE CUPS** – Fill grease cups with water pump grease. Grease cup cap should be firmly tightened about every 50 hours of pump service while pump is operating. Leakage may occur through grease cups at pressures above 20 p.s.i. If this occurs, replace grease cups with ball check grease cups.
12. **SPARE PARTS** – To avoid costly shut downs, keep a Jabsco Service Kit on hand.

SERVICE INSTRUCTIONS

DISASSEMBLY

1. Remove end cover screws, end cover and gasket.
2. Remove drive coupling or pulley and loosen packing nut.
3. Remove shaft and impeller assembly from body.
4. Slide impeller off shaft towards pump drive end.
5. Remove cam screw and cam, clean off Permatex.
6. Remove packing nut and gland.
7. Remove packing with pick or screwdriver.
8. Remove grease cup caps and clean grease cups. Use a small wire to ensure grease passage is open to shaft bore.
9. Inspect all parts for wear or damage and replace if necessary.

ASSEMBLY

1. Dip new packing in SAE 10 or 20 weight oil and install packing, packing gland and packing nut.
2. Apply sealant to cam screw threads and top and back end of cam and install in body with cam screw.
3. Install impeller key in shaft (dress if necessary) and slide the impeller on the shaft **from the pump drive end**.

Impeller can be installed in only one direction; pinned end of keyway toward drive end of pump.
4. Install shaft and impeller assembly in body. (Dip shaft in SAE 10 or 20 weight oil and lube impeller bore with water pump grease prior to assembly.)
5. Install gasket and end cover with end cover screws.
6. Fill grease cups full and grease cup caps 3/4 full with water pump grease. Install grease cup caps and tighten firmly.
7. Hand tighten packing nut. During operation, tighten packing nut until pump stops dripping; set locking nut. **NOTE:** Packing and shaft life will be improved if pump is allowed to drip about 3 drops per minute. After a few minutes of operation, re-tighten grease cup caps.

EXPLODED VIEW

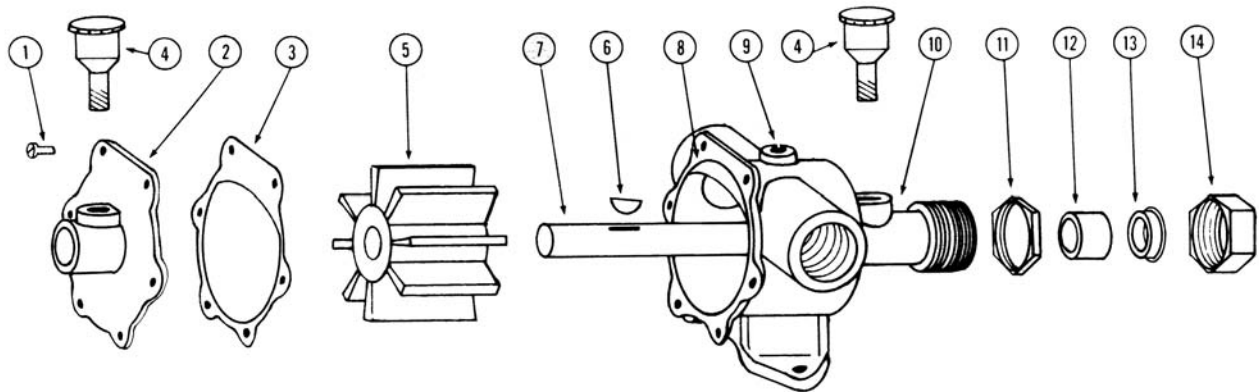

PARTS LIST

Key	Description	Qty.	Model 4560 Series	Model 4590 Series	Model 4620 Series
1	Screw (End Cover)	6	91002-0020	91003-0010	91003-0010
2	End Cover	1	4565-0000	4595-0000	4595-0000
3	Gasket*	1	7083-0000	706-0010	706-0010
4	Grease Cup	2	91501-0010	91501-0010	91501-0010
5	Impeller*	1			
	Neoprene		4568-0001	4598-0001	4598-0001
	Nitrile		4568-0003	4598-0003	4598-0003
6	Key (Impeller Drive)*	1	91402-0010	91402-0010	91402-0010
7	Shaft	1	4567-0000	4597-0000	4597-0000
8	Cam	1	490-0001	17612-0000	17612-0000
9	Screw (Cam)	1	91003-0070	91004-0010	91004-0010
10	Body	1	4564-0000	4594-0000	4624-0000
11	Lock Nut	1	4517-0000	4517-0000	4517-0000
12	Packing (Ring)*	1	3791-0000	3791-0000	3791-0000
13	Packing (Gland)	1	4518-0000	4518-0000	4518-0000
14	Packing Nut	1	4583-0000	4583-0000	4583-0000
	Key Pump Drive (not shown)	1	9215-0000	9215-0000	9215-0000
	Service Kit (not shown)				
	w/ Neoprene Impeller		90003-0001	90004-0001	90004-0001
	w/ Nitrile Impeller		90003-0003	90004-0003	90004-0003

* Parts supplied in Service Kit

DIMENSIONAL DRAWING

Inches (Millimetres)

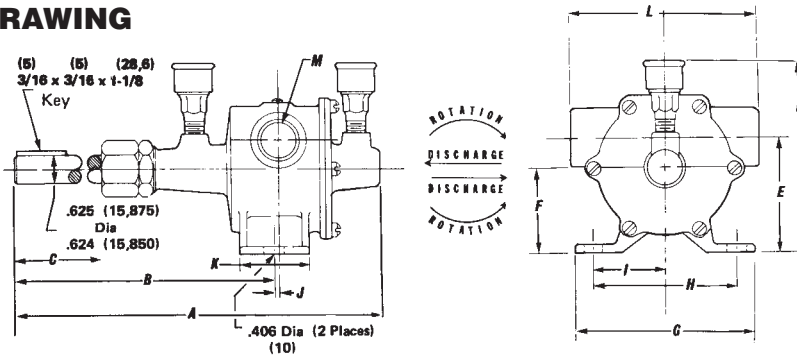

TABULATIONS FROM ABOVE DRAWING

Model	A	B	C	D	E	F	G	H	I	J	K	L	M
4560-Series	7-1/8" (181)	5-1/8" (130,2)	1-7/8" Min. (47,6)	4" (101,6)	2-1/2" (63,5)	1-15/16" (49,2)	3-3/4" (95,3)	3" (76,2)	1-1/2" (38,1)	3/16" (4,8)	1-3/16" (30,2)	4-1/8" (104,8)	1/2" NPT Int. (2 Places)
4590-Series	7-7/8" (200)	5-9/16" (141,3)	1-3/4" Min. (44,5)	4-3/16" (106,4)	2-1/2" (63,5)	1-7/8" (47,6)	3-15/16" (100)	3-1/8" (79,4)	1-9/16" (39,7)	3/32" (2,4)	1-1/2" (38,1)	4-1/8" (104,8)	3/4" NPT Int. (2 Places)
4620-Series	7-7/8" (200)	5-5/8" (142,9)	1-3/4" Min. (44,5)	4-3/16" (106,4)	2-1/2" (63,5)	1-7/8" (47,6)	3-15/16" (100)	3-1/8" (79,4)	1-9/16" (39,7)	1/8" (3,2)	1-1/2" (38,1)	4-3/4" (120,7)	1" NPT Int. (2 Places)

HEAD CAPACITY TABLE

Model 4560-0001

Total Head		500 RPM		1160 RPM		1750 RPM		2100 RPM		2450 RPM		3000 RPM		3600 RPM	
p.s.i. (kg/sq cm)	ft. of water (metres)	GPM (L/min)	hp	GPM (L/min)	hp	GPM (L/min)	hp	GPM (L/min)	hp	GPM (L/min)	hp	GPM (L/min)	hp	GPM (L/min)	hp
4.3 (0,3)	10 (3,0)	3.0 (11,3)	1/6	7.6 (28,8)	1/4	11.0 (41,6)	1/2	13.0 (49,2)	1/2	15.2 (57,5)	1/2	18.0 (68,1)	3/4	19.6 (74,2)	3/4
8.7 (0,6)	20 (6,1)	1.8 (6,8)	1/6	6.4 (24,2)	1/4	10.0 (37,9)	1/2	11.5 (43,5)	1/2	13.7 (51,9)	1/2	17.0 (64,3)	3/4	18.8 (71,2)	3/4
13 (0,9)	30 (9,1)	—	—	4.8 (18,2)	1/3	8.5 (32,2)	1/2	10.0 (37,9)	1/2	12.0 (45,4)	1/2	15.3 (57,9)	3/4	17.5 (66,2)	3/4
21.6 (1,5)	50 (15,2)	—	—	—	—	5.0 (18,9)	1/2	6.7 (25,4)	3/4	8.5 (32,2)	3/4	11.8 (44,7)	3/4	14.5 (54,9)	1

HEAD CAPACITY TABLE

Models 4590-0001, 4620-0001

Total Head		500 RPM		1160 RPM		1750 RPM		2100 RPM		2450 RPM		3000 RPM	
p.s.i. (kg/sq cm)	ft. of water (metres)	GPM (L/min)	hp	GPM (L/min)	hp	GPM (L/min)	hp	GPM (L/min)	hp	GPM (L/min)	hp	GPM (L/min)	hp
4.3 (0,3)	10 (3,0)	7.0 (26,5)	1/4	16.5 (62,5)	1/3	25.0 (94,6)	3/4	29.0 (109,8)	3/4	31.0 (117,3)	1	33.0 (124,9)	1-1/2
8.7 (0,6)	20 (6,1)	6.5 (24,6)	1/4	16.0 (60,6)	1/3	24.5 (92,7)	3/4	28.5 (107,9)	3/4	30.5 (115,4)	1	32.5 (123,0)	1-1/2
13 (0,9)	30 (9,1)	6.0 (22,7)	1/4	15.0 (56,8)	1/3	23.0 (87,1)	3/4	27.0 (102,2)	1	29.0 (109,8)	1	32.0 (121,1)	1-1/2
21.6 (1,5)	50 (15,2)	—	—	11.5 (43,5)	1/2	19.0 (71,9)	3/4	22.5 (85,2)	1	25.0 (94,6)	1-1/2	30.5 (115,4)	2

NOTE: Progressively longer life may be expected as operating pressures and speeds are reduced. Factory Application Engineering assistance suggested for operation in light shaded areas and recommended for heavy shaded areas. Capacitor type motor required. Table shows approximate Head-Flow for new pump in U.S. gallons per minute and litres per minute, for neoprene compound impeller.

Jabsco



ITT Industries

Engineered for life

THE PRODUCTS DESCRIBED HEREIN ARE SUBJECT TO THE JABSCO ONE YEAR LIMITED WARRANTY, WHICH IS AVAILABLE FOR YOUR INSPECTION UPON REQUEST.

U.S.A.
 Jabsco
 1485 Dale Way, P.O. Box 2158
 Costa Mesa, CA 92628-2158
 Tel: 714.545.8251
 Fax: 714.957.0609

UNITED KINGDOM
 Jabsco
 Bingley Road, Hoddesdon
 Hertfordshire EN11 0BU
 Tel: +44 (0) 1992 450145
 Fax: +44 (0) 1992 467132

CANADA
 Fluid Products Canada
 55 Royal Road
 Guelph, Ontario N1H 1T1
 Tel: (519) 821.1900
 Fax: (519) 821.2569

JAPAN
 NHK Jabsco Company Ltd.
 3-21-10, Shin-Yokohama
 Kohoku-Ku, Yokohama, 222
 Tel: 045.475.8906
 Fax: 045.475.8908

GERMANY
 Jabsco GmbH
 Oststrasse 28
 22840 Norderstedt
 Tel: +49-40-53 43 73 -0
 Fax: +49-40-53 53 73 -11