



Models 38110-Series
38120-Series
38140-Series

HOLDING TANK – WASTE MANAGEMENT SYSTEM TYPE III MSD

FEATURES

Rugged Polyethylene Holding Tank

- Evacuation pick-up for included waste pump
- Includes Dock-side pump-out pick-up
- Convenient mounting points
- 1-1/2" (38mm) x 90° Barbed Inlet Port
- 3/4" (19mm) x 90° Barbed Vent Port
- 3" (76mm) Clean-out Access Cover

Heavy Duty Macerator Evacuation Pump

- 12 GPM flow rate
- Integral Run-Dry Protection Device
- Self-priming

Waste Management Control Panel

- 1/4, 1/2, 3/4 and Full Level Indicators
- At the 3/4 level the Full indicator blinks continuously to warn of nearing full, and glows solid when full
- "One Touch" Macerator Activation
- Automatic Macerator Shut-off when empty
- Easy Plug-in Electrical Connections

VARIATIONS AVAILABLE

MODEL NO.	DESCRIPTION
38110-0092	10 (38 litres) Gallon, 12 Volt
38110-0094	10 (38 litres) Gallon, 24 Volt
38120-0092	20 (76 litres) Gallon, 12 Volt
38120-0094	20 (76 litres) Gallon, 24 Volt
38140-0092	40 (150 litres) Gallon, 12 Volt
38140-0094	40 (150 litres) Gallon, 24 Volt



Model 38110 / 38120 / 38140-Series

SYSTEM OPERATION

The Jabsco Holding Tank/Waste System consists of a rugged Polyethylene Holding Tank, Macerator Waste Evacuation Pump and a Waste Management Control Panel that indicates tank level and activates the Macerator Pump when desired. The Control Panel includes tank level LEDs to indicate 1/4, 1/2, 3/4 and Full tank levels. Depressing a momentary rocker switch illuminates the 1/4, 1/2 & 3/4 level LEDs. When the tank is 3/4 full, the full indicator blinks continuously to draw attention to the fact that the tank is nearing the full level. When the tank is full, the full indicator glows constant red.

When ready to empty the Holding Tank, if the vessel is in a location where it is legal to discharge directly overboard (beyond the three mile limit), simply depress the momentary rocker switch to activate the system's Macerator Pump. The Macerator will continue to run until the tank is empty, at which time the tank monitoring system will automatically turn off the Macerator. If the Macerator needs to be turned off prior to the tank being completely emptied, simply depress the Macerator activation switch a second time to stop the pump.

INSTALLATION

The Holding Tank and Pump Assembly should be located as close as practical to the toilet and the discharge thru-hull. Generally, the discharge thru-hull is positioned in the side of the hull, in or near the boot stripe, so it is just above the waterline. If the discharge thru-hull is positioned below the water line, it must include a proper seacock. If the discharge thru-hull and the Holding Tank

are both below the waterline, to prevent water from siphoning back into the Holding Tank, the discharge hose must include a Vented Loop Fitting positioned at least 8" above the water line at all angles of heel and trim. If unfamiliar with the proper installation of a vented loop fitting, consult a qualified marine plumber.

The location for the Holding Tank must provide a flat mounting surface, for it to rest on, that is both level and sturdy enough to support the weight of a full holding tank. The approximate weights of full Holding Tanks are as follows:

MODEL NO.	DESCRIPTION	WEIGHT
38110-Series	Holding Tank & Macerator 10 Gal.	90 lb.
38120-Series	Holding Tank & Macerator 20 Gal.	180 lb.
38140-Series	Holding Tank & Macerator 40 Gal.	360 lb.

All Holding Tanks may be secured to the platform with four machine or lag screws through the four slots in the mounting point alcoves with either machine or lag screws and flat washers. The 20 and 40 gallon Holding Tanks may also be secured by strapping material secured over the top of the tanks and positioned in the strap grooves. The strapping material should be heavy-duty fabric (such as nylon) or alternatively metal strapping placed over padding to avoid abrasion.

PLUMBING

Each tank is fitted with a waste evacuation pick-up tube with 1-1/2" (38mm) hose barb for connection to a dock-side pump-out deck plate. Additionally, the top of the tank includes a 1-1/2" hose barb to accept the toilet discharge plumbing. It also has a 3/4" (19mm) hose barb to accept the attachment of a tank vent. Holding Tank vent fittings are generally installed high on a vessel's hull near the gunwale. The macerator discharge is a 1" (25mm) hose barb and 1" (25mm) hose should be used to connect to the overboard discharge thru-hull. It is a good practice to clamp waste hoses using two stainless steel band clamps at each connection.

ELECTRICAL

The electrical circuit must be independent of all other accessories and made with marine grade stranded copper wire. Determine the proper wire size for the electrical circuit from the Electrical Specifications Chart based on the total length of the circuit (both positive and negative conductors). The positive conductor should be connected to, and pick-up its power from, an overload protected electrical distribution panel with the correct size circuit breaker or fuse as determined from the Electrical Specifications Chart. Connect both the positive and negative conductors to the Holding Tank's electrical buss on top of the tank.

Determine an appropriate location for the Waste Management Control Panel that will allow easy connection of the panel with the Holding Tank using the system's ten foot wiring harness. Cover the mounting surface with tape to protect it from damage when drilling and sawing

the panel clearance hole. Using the Control Panel Mounting Template, mark the location of the holes to be drilled with a 3/8 (10mm) drill and the material to be removed with a saber saw plus the location of the four corner mounting screws. Drill four 3/8 (10mm) diameter corner holes and use a saber saw to remove material from the mounting surface to provide clearance for the panel's electrical circuit board. Plug one end of the wiring harness into the mating receptacle on the Holding Tank and secure to the tank with the strain relief clips. Feed the other end of the harness through the hole in the panel's mounting surface and plug it into the receptacle on the rear of the Control Panel. Secure the Control Panel to its mounting surface with four screws. It is recommended that the wiring harness be secured with wire ties to a solid mounting surface about every 18" (45cm) along its length to prevent movement and abrasion.

ELECTRICAL SPECIFICATIONS

VOLTAGE	AMP DRAW	FUSE SIZE	WIRE SIZE PER FEET OF RUN*				
			0'-10'	10'-15'	15'-25'	25'-40'	40'-60'
12 Vdc	16	20	#12 (4)	#10 (6)	#10 (6)	#8 (10)	#6 (16)
24 Vdc	8	15	#16 (1.5)	#14 (2.5)	#12 (4)	#10 (6)	#10 (6)

* Length of run is total length of the circuit from the power source to product and back to ground. Wire sizes listed are SAE gauge and metric millimetres².

MAINTENANCE

The Jabsco Waste Management System does not require periodic or routine maintenance. However, it is considered a good practice to occasionally flush the system with a generous amount of clean water to flush out any build-up of sludge or debris. To do this, simply fill the tank to approximately 1/4 full with clean water either by flushing a toilet or by adding water through the 3" inspection port. Allow the water to slosh in the tank (from normal boat motion while underway) for about five minutes. Then, if operating in an area where it is legal to discharge overboard (beyond the three mile limit in open ocean waters and not in a designated "no discharge zone") pump the flush water from the tank or alternatively, remove the flush water at a dockside pump-out facility. The frequency of flushing depends on the vessels' total usage, but for most privately owned pleasure boats, once a season is adequate cleaning. It may be convenient to perform such flushing while preparing the vessel for an off season lay up.

WINTERIZING

If the vessel is located in an area that experiences freezing temperatures, the holding tank should be "winterized" during cold weather periods. This can be accomplished by removing all water possible from the tank, either by the unit's⁰ Macerator evacuation pump (where legal to do so) or at a dockside pump out facility. Then add an amount of either alcohol or glycol based antifreeze equal to about 5% of the tank's total capacity to the small amount of residual water that remains in the tank.

EXPLODED VIEW

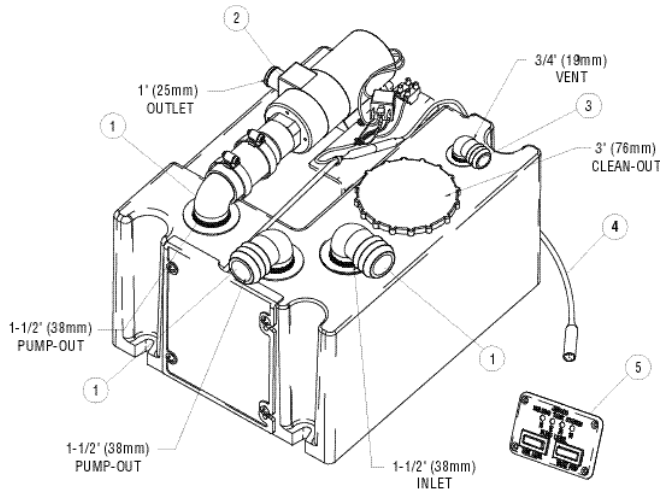

PARTS LIST

Key	Description	Qty.	Part Number
1	1-1/2" Barbed Elbow Pick-up Tube	2	38112-6000
2	Macerator Motor - 12Volt CE	1	18590-1090
	Macerator Motor - 24Volt CE	1	18590-1001
3	10 Foot Control Cable	1	47010-6000
	15 Foot Control Cable	1	47015-6000
	20 Foot Control Cable	1	47020-6000
	30 Foot Control Cable	1	47030-6000
4	Control Panel - 12Volt	1	38111-6012
	Control Panel - 24Volt	1	38111-6024

LEVEL SENSOR CONNECTIONS

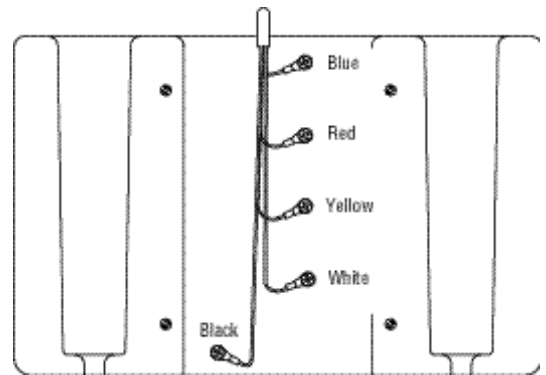

RELAY SWITCH

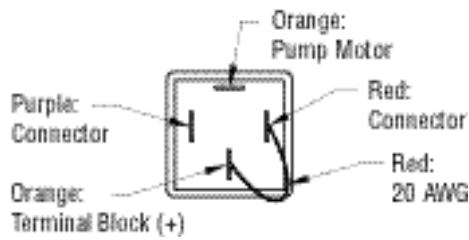

TEMPLATE

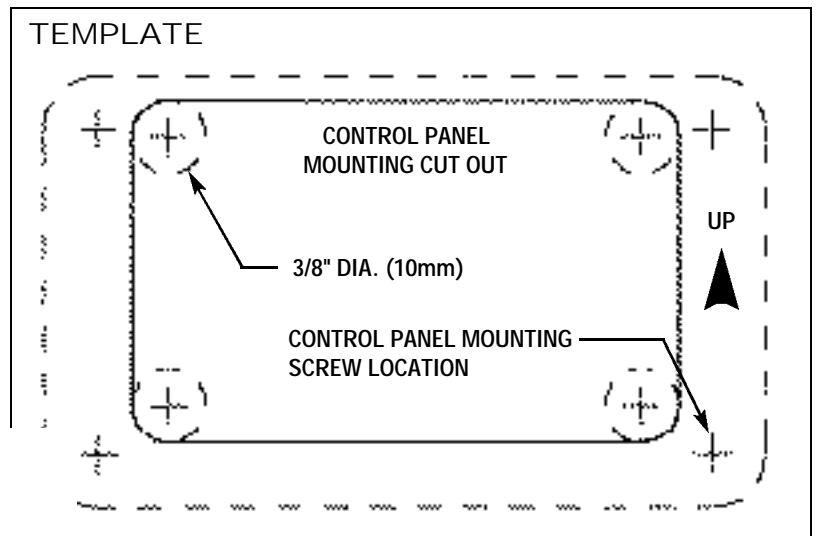

TERMINAL BLOCK WIRE CODE

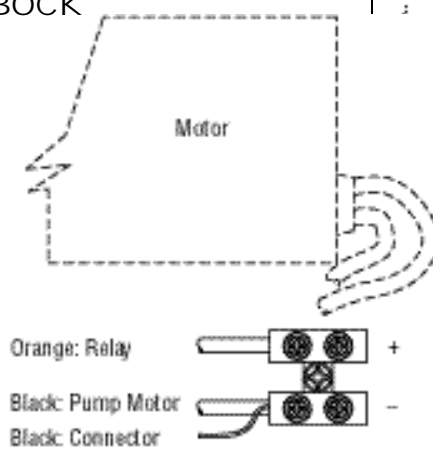

DIMENSIONAL DRAWING
Inches (Centimetres)

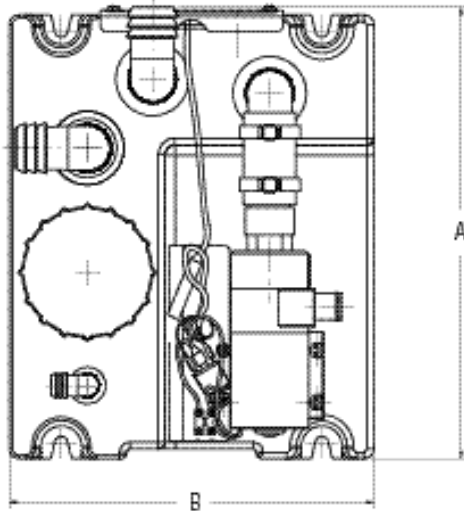

Key	TANK SIZE		
	10 Gal. (38 Litre)	20 Gal. (76 Litre)	40 Gal. (150 Litre)
A	17-3/8 (43.9)	21 (53.3)	25-1/2 (64.8)
B	14 (35.6)	24 (61.0)	38-1/2 (97.8)

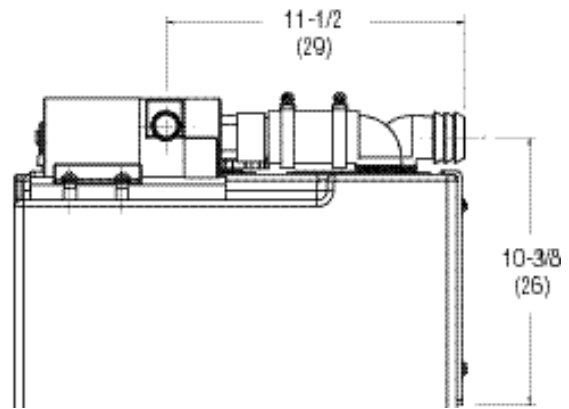
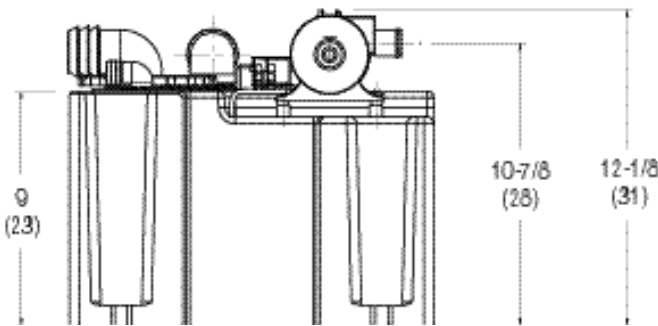

Jabsco



ITT Industries
Engineered for life

THE PRODUCTS DESCRIBED HEREIN ARE SUBJECT TO THE JABSCO ONE YEAR LIMITED WARRANTY, WHICH IS AVAILABLE FOR YOUR INSPECTION UPON REQUEST.

U.S.A.
Jabsco
20 Icon
Foothill Ranch, CA 92610-3000
Tel: 949.609.5106
Fax: 949.859.1254

UNITED KINGDOM
Jabsco
Bingley Road, Hoddesdon
Hertfordshire EN11 OBU
Tel: +44 (0) 1992 450145
Fax: +44 (0) 1992 467132

CANADA
Fluid Products Canada
55 Royal Road
Guelph, Ontario N1H 1T1
Tel: (519) 821.1900
Fax: (519) 821.2569

JAPAN
NHK Jabsco Company Ltd.
3-21-10, Shin-Yokohama
Kohoku-Ku, Yokohama, 222
Tel: 045.475.8906
Fax: 045.475.8908

GERMANY
Jabsco GmbH
Oststrasse 28
22840 Norderstedt
Tel: +49-40-53 53 73 -0
Fax: +49-40-53 53 73 -11