

ITEM	PART NO	DESCRIPTION	QTY				
			-0001	-0011	-0021	-0051	-0151-3000
1	2564-8000	BODY - CASTING	1	1	1	1	1
1	2564-0000	BODY - MACHINING	REF	REF	REF	REF	REF
1	2564-0010	BODY - MACHINING	REF	REF	REF	REF	REF
2	2566-0020	ADAPTOR	1	1	1	1	1
3	2567-6001	SHAFT	1	1	1	1	1
4	15397-0000	END COVER	1	1	1	1	1
5	834-6001	CAM	1	1	1	1	1
5	2551-6000	CAM				1	1
6	17935-0111	IMPELLER	1	1	1	1	1
7	2574-6000	WEAR PLATE	1	1	1	1	1
8	96080-0374	SEAL, SUB-ASSY	1	1	1	1	1
9	10162-0000	SEAL, CUP	1	1	1	1	1
10	10163-0000	SEAL, SEAT	1	1	1	1	1
11	817-6000	SEAL, LIP	1	1	1	1	1
12	4346-0001	SEAL, SPLINE	1	1	1	1	1
13	3181-6000	SLINGER	1	1	1	1	1
14	816-6000	GASKET	1	1	1	1	1
14	2553-0000	GASKET				1	1
15	92600-6040	BEARING, BALL	1	1	1	1	1
16	91402-0050	KEY, WOODRUFF	1	1	1	1	1
17	91700-2460	RING, RETAINING	1	1	1	1	1
18	91700-2450	RING, RETAINING	1	1	1	1	1
19	92000-1372	O-RING	1	1	1	1	1
20	2581-6000	GEAR, DRIVE	1	1	1	1	1
21	91095-1272	SCREW, HEX HD 3/8-16 x 1.00, CRES	6	6	6	6	6
22	91095-0060	SCREW, HEX HD, 1/4-20 x 1/2, CRES	5	5	5	5	5
23	91005-6040	SCREW, FILL HD, 1/4-20 x 1/2, BRASS	1	1	1	1	1
23	91005-0050	SCREW, FILL HD, 1/4-20 x 1/2, BRASS				1	1
24	2575-6000	PIN, DOWEL	1	1	1	1	1
25	91608-0010	WASHER, LOCK	1	1	1	1	1
26	91602-0090	WASHER, LOCK	6	6	6	6	6
27	91605-0070	WASHER	6	6	6	6	6
28	91085-0100	NUT, JAM	1	1	1	1	1

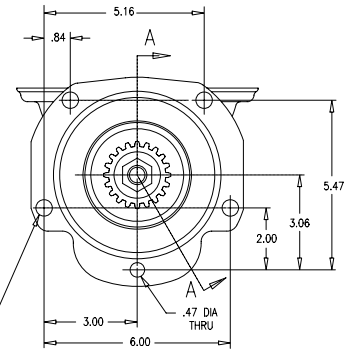
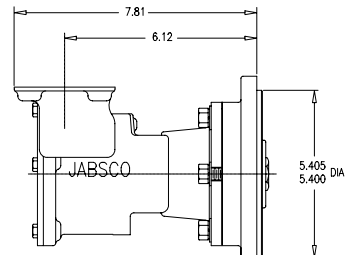
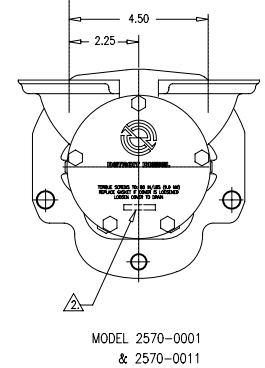
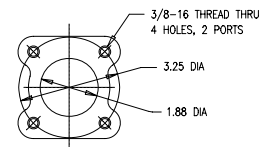
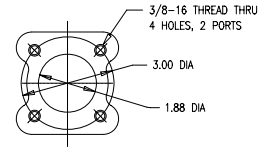
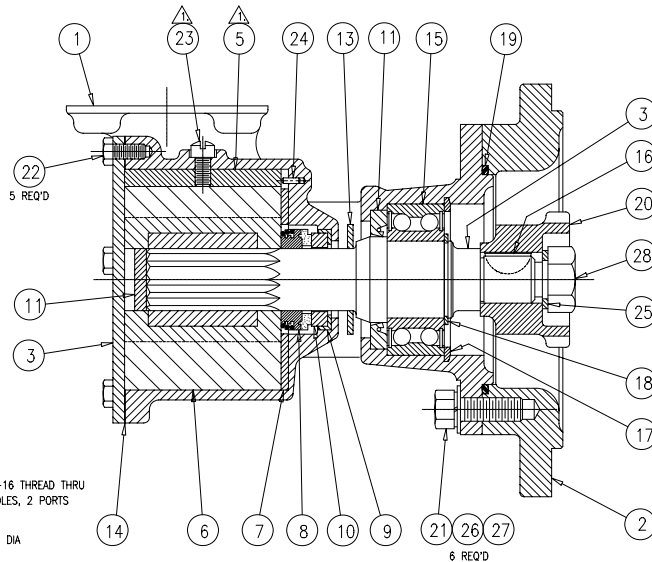

NOTES: UNLESS OTHERWISE SPECIFIED  
 ⚠️ COAT O.D. OF CAM, ITEM 5 AND THREADS OF CAM SCREW, ITEM 21, WITH PERMATEX FORM-A-GASKET RESIN SOLUTION.  
 ⚠️ MARK END COVER, ITEM 4 WITH DDC PART NO. DO NOT MARK WITH JABSCO MODEL NO.

JABSCO MODEL NO.	DDC PART NO.
2570-0001	5186250
2570-0011	5115396
2570-0021	5107480
2570-0051	23501083
2570-0151	23513002
2570-3000	23507971

TORQUE REQUIREMENTS

ITEM	REQUIRED TORQUE
21	13 - 15 FT/LBS
22	75 - 80 IN/LBS
23	42 - 46 IN/LBS
28	35 - 40 FT/LBS

REV	DESCRIPTION	ECO NO	BY	DATE	CHK	DATE	APVD	DATE
P1	REVISED & REWORK (COMBINED INSTALL, ASSY & BILL OF MATL)	1033	HY	3-18-80	JN	4-18-80	NS	4-28-80
P2	REVISED DOW PER DOPS	"	"	"	"	"	"	"
R1	ASSED 2564-8010, BODY - CASTING TO ITEM 1	1820	HY	1-17-82	VM	1-29-82	VM	1-29-82
S	SEE UK ECH	12391	LAB	10/20/83				
T	SEE UK ECH	15460	J N R	22/11/84				
U	SEE UK ECH	13963	J N R	14/12/85				

UNLESS OTHERWISE SPECIFIED ALL DIMENSIONS ARE IN INCHES ALL DIMENSIONS AND TOLERANCING PER ASME Y14.5M-1994	TOLERANCES ARE: FRACTIONS: +1/32 DECIMALS: .XX-± XXX-± ANGULAR: ±	MATL SPEC: _____ APPROVALS: _____ DATE: _____ DRAWN BY: H. YU 3/10/00 CHECKED BY: J. NEMSHOK 4/18/00 APP'D BY: N. SANTOS 4/20/00 DO NOT SCALE DRAWING	IT Industries JABSCO COSTA MESA, CA FLOJET Foothill Ranch, CA
"THIS DOCUMENT CONTAINS PROPRIETARY INFORMATION OF IT INDUSTRIES. THIS DOCUMENT IS ISSUED IN STRICT CONFIDENCE AND SHALL NOT BE DISCLOSED TO A THIRD PARTY OR USED FOR MANUFACTURE, PRODUCTION OR PROCUREMENT WITHOUT THE EXPRESS WRITTEN PERMISSION OF IT INDUSTRIES."		TITLE: DETROIT DIESEL PUMP DWG NO: 2570-XXXX SCALE: 1:2 & NOTED	

D

C

B

A

D

C

B

A