

ITEM	PART NO	DESCRIPTION	QTY					
			-0001	-0011	-0021	-0051	-0151-3000	
1	2564-8000	BODY - CASTING	1	1	1	1	1	1
1	2564-0000	BODY - MACHINING	REF	REF	REF	REF	REF	REF
1	2564-0010	BODY - MACHINING	REF	REF	REF	REF	REF	REF
2	2566-0020	ADAPTOR	1	1	1	1	1	1
3	2567-6001	SHAFT	1	1	1	1	1	1
4	15397-0000	END COVER	1	1	1	1	1	1
5	834-6001	CAM	1	1	1	1	1	1
5	2551-6000	CAM				1	1	
6	17935-0111	IMPELLER	1	1	1	1	1	1
7	2574-6000	WEAR PLATE	1	1	1	1	1	1
8	96080-0374	SEAL, SUB-ASSY	1	1	1	1	1	1
9	10162-0000	SEAL, CUP	1	1	1	1	1	1
10	10163-0000	SEAL, SEAT	1	1	1	1	1	1
11	817-6000	SEAL, LIP	1	1	1	1	1	1
12	4346-0001	SEAL, SPLINE	1	1	1	1	1	1
13	3181-6000	SLINGER	1	1	1	1	1	1
14	816-6000	GASKET	1	1	1	1	1	1
14	2553-0000	GASKET				1	1	
15	92600-6040	BEARING, BALL	1	1	1	1	1	1
16	91402-0050	KEY, WOODRUFF	1	1	1	1	1	1
17	91700-2460	RING, RETAINING	1	1	1	1	1	1
18	91700-2450	RING, RETAINING	1	1	1	1	1	1
19	92000-1372	O-RING	1	1	1	1	1	1
20	2581-6000	GEAR, DRIVE	1	1	1	1	1	1
21	91095-1272	SCREW, HEX HD 3/8-16 x 1.00, CRES	6	6	6	6	6	6
22	91095-0060	SCREW, HEX HD, 1/4-20 x 1/2, CRES	5	5	5	5	5	5
23	91005-6040	SCREW, FILL HD, 1/4-20 x 1/2, BRASS	1	1	1	1	1	1
23	91005-0050	SCREW, FILL HD, 1/4-20 x 1/2, BRASS				1	1	
24	2575-6000	PIN, DOWEL	1	1	1	1	1	1
25	91608-0010	WASHER, LOCK	1	1	1	1	1	1
26	91602-0090	WASHER, LOCK	6	6	6	6	6	6
27	91605-0070	WASHER	6	6	6	6	6	6
28	91085-0100	NUT, JAM	1	1	1	1	1	1

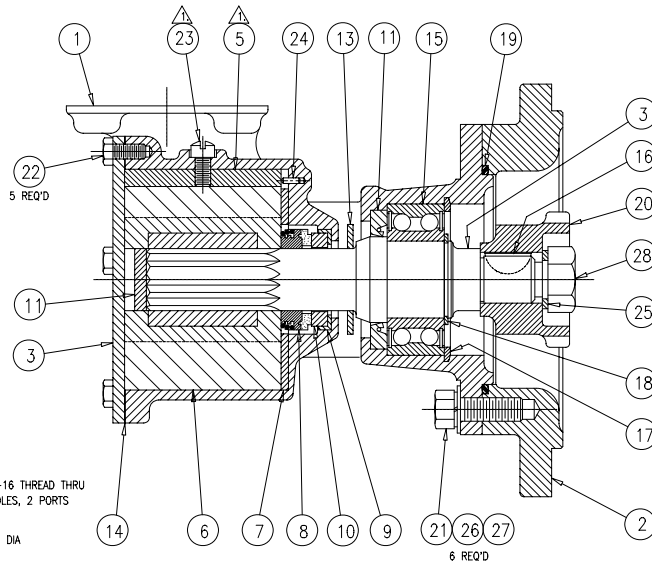

SECTION A-A
SCALE: 1/1

MODEL 2570-0001 ONLY

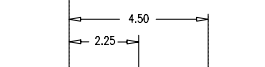
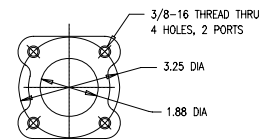

MODEL 2570-0001
& 2570-0011

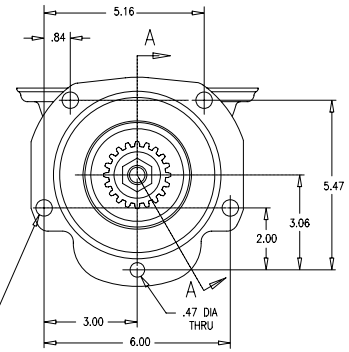
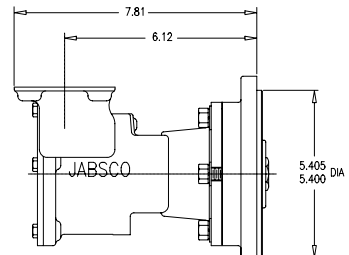

NOTES: UNLESS OTHERWISE SPECIFIED
 ⚠ COAT O.D. OF CAM, ITEM 5 AND THREADS OF CAM SCREW, ITEM 21, WITH PERMATEX FORM-A-GASKET RESIN SOLUTION.
 ⚠ MARK END COVER, ITEM 4 WITH DDC PART NO. DO NOT MARK WITH JABSCO MODEL NO.
 JABSCO MODEL NO. DDC PART NO.
 2570-0001 5186250
 2570-0011 5115396
 2570-0021 5107480
 2570-0051 23501083
 2570-0151 23513002
 2570-3000 23507971

TORQUE REQUIREMENTS

ITEM	REQUIRED TORQUE
21	13 - 15 FT/LBS
22	75 - 80 IN/LBS
23	42 - 46 IN/LBS
28	35 - 40 FT/LBS

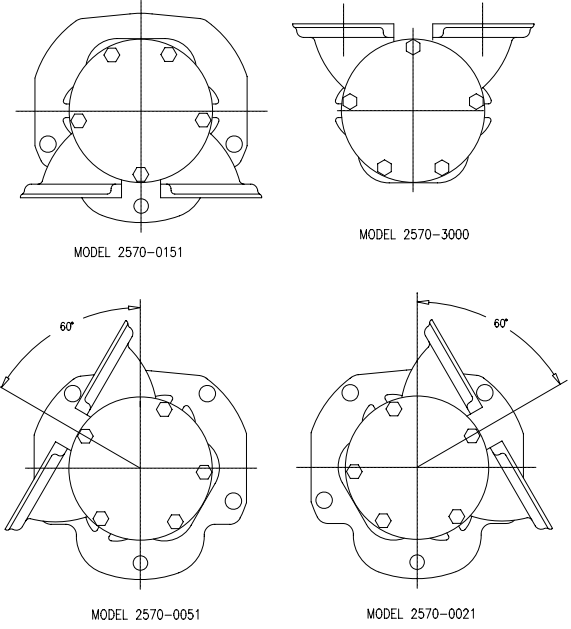

MODEL 2570-0051

MODEL 2570-0021

REV	DESCRIPTION	ECO NO	BY	DATE	CHK	DATE	APVD	DATE
P1	REVISED & REWORK (COMBINED INSTALL, ASSY & BILL OF MATL)	1033	HY	3-18-80	JN	4-18-80	NS	4-28-80
P2	REVISED DRAW PER ROPS							
R1	ASSED 2564-8010, BODY - CASTING TO ITEM 1	1820	HY	1-17-82	VM	1-29-82	VM	1-29-82
S	SEE UK ECH	12391	LAB	10/20/83				
T	SEE UK ECH	15460	J N R	22/11/84				
U	SEE UK ECH	13963	J N R	14/12/85				

UNLESS OTHERWISE SPECIFIED ALL DIMENSIONS ARE IN INCHES ALL DIMENSIONS AND TOLERANCING PER ASME Y14.5M-1994	TOLERANCES ARE: FRACTIONS: +1/32 DECIMALS: .XX-± XXX-±	MATL SPEC	IT Industries JABSCO COSTA MESA, CA FLOUJET Foothill Ranch, CA
	APPROVALS	DATE	
"THIS DOCUMENT CONTAINS PROPRIETARY INFORMATION OF IT INDUSTRIES. THIS DOCUMENT IS ISSUED IN STRICT CONFIDENCE AND SHALL NOT BE DISCLOSED TO A THIRD PARTY OR USED FOR MANUFACTURE, PRODUCTION OR PROCUREMENT WITHOUT THE EXPRESS WRITTEN PERMISSION OF IT INDUSTRIES."		DRAWN BY: H. YU 3/10/00 CHECKED BY: J. NEMSHOK 4/19/00 APVD BY: N. SANTOS 4/20/00 DO NOT SCALE DRAWING	TITLE: DETROIT DIESEL PUMP SIZE: D COMPUTER FILE NO: 2570-XXXX DWG NO: 2570-XXXX SHEET 1 OF 1