

# Models

# P470 / P490

---

Triplex Ceramic  
Plunger Pump  
Operating Instructions/  
Repair and Service Manual

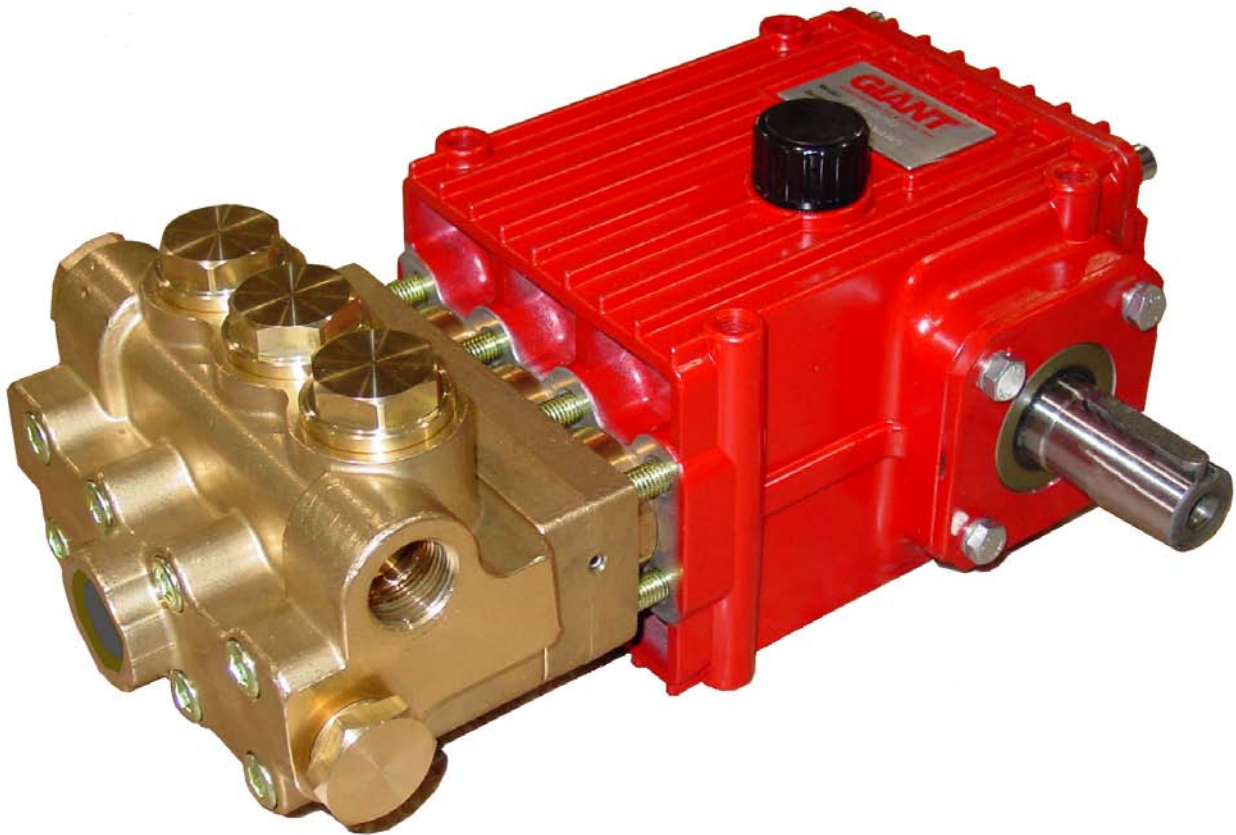

Updated 01/12

---

## Contents:

Installation Instructions:	page 2
Recommended Spare Parts List:	page 3
Pump Mounting Selection Guide:	page 3
Torque Specifications:	page 3
Pump Specifications-P470:	page 4
Pump Specifications-P490:	page 5
Exploded View:	page 6
Parts List / Kits:	page 7
Repair Instructions:	pages 8-10
Dimensions:	page 11
Warranty Information:	back page

# INSTALLATION INSTRUCTIONS

**Installation of the Giant Industries, Inc., pump is not a complicated procedure, but there are some basic steps common to all pumps. The following information is to be considered as a general outline for installation. If you have unique requirements, please contact Giant Industries, Inc. or your local distributor for assistance.**

1. The pump should be installed flat on a base to a maximum of a 15 degree angle of inclination to ensure optimum lubrication.
2. The inlet to the pump should be sized for the flow rate of the pump with no unnecessary restrictions that can cause cavitation. Teflon tape should be used to seal all joints. If pumps are to be operated at temperatures in excess of 158° F, it is important to insure a positive head to the pump to prevent cavitation.
3. The discharge plumbing from the pump should be properly sized to the flow rate to prevent line pressure loss to the work area. It is essential to provide a safety bypass valve between the pump and the work area to protect the pump from pressure spikes in the event of a blockage or the use of a shut-off gun.

4. Use of a dampener is necessary to minimize pulsation at drive elements, plumbing, connections, and other system areas. The use of a dampener with Giant Industries, Inc. pumps is optional, although recommended by Giant Industries, Inc. to further reduce system pulsation. Dampeners can also reduce the severity of pressure spikes that occur in systems using a shut-off gun. A dampener must be positioned downstream from the unloader.

5. Crankshaft rotation on Giant Industries, Inc. pumps should be made in the direction designated by the arrows on the pump crankcase. Reverse rotation may be safely achieved by following a few guidelines available upon request from Giant Industries, Inc. Required horsepower for system operation can be obtained from the chart on page 3.

6. Before beginning operation of your pumping system, remember: Check that the crankcase and seal areas have been properly lubricated per recommended schedules. Do not run the pump dry for extended periods of time. Cavitation will result in severe damage. Always remember to check that all plumbing valves are open and that pumped media can flow freely to the inlet of the pump.

Finally, remember that high pressure operation in a pump system has many advantages. But, if it is used carelessly and without regard to its potential hazard, it can cause serious injury.

## IMPORTANT OPERATING CONDITIONS

**Failure to comply with any of these conditions invalidates the warranty.**

1. Prior to initial operation, add oil to the crankcase so that oil level is between the two lines on the oil dipstick. **DO NOT OVERFILL.**

**Use Giant Oil # 01154 or the equivalent SAE 80W - 90 Industrial Gear Oil**

Crankcase oil should be changed after the first 50 hours of operation, then at regular intervals of 200 hours or less depending on operating conditions.

2. Pump operation must not exceed rated pressure, volume, or RPM. A pressure relief device must be installed in the discharge of the system.

3. Acids, alkalines, or abrasive fluids cannot be pumped unless approval in writing is obtained before operation from Giant Industries, Inc.

4. Run the pump dry approximately 10 seconds to drain the water before exposure to freezing temperatures.

**NOTE: Contact Giant Industries for Service School Information. Phone: (419)-531-4600**

<b>Preventative Maintenance Check List &amp; Recommended Spare Parts List</b>						
<b>Check</b>	<b>Daily</b>	<b>Weekly</b>	<b>50 Hrs.</b>	<b>Every 500 Hours</b>	<b>Every 1500 Hours</b>	<b>Every 3000 Hours</b>
Oil Level/Quality	X					
Oil Leaks	X					
Water Leaks	X					
Belts, Pulley		X				
Plumbing		X				
<b>Recommended Spare Parts</b>						
Oil Change p/n 01153			X	X		
Plunger Seal Kit (1 kit/pump)*					X	
Oil Seal Kit (1 kit/pump)*					X	
Valve Repair Kit (1 kit/pump)*						X

\*See page 5 for kit list

### Pump Mounting Selection Guide

<p><b>Bushings</b> 07175 - 28mm Tapered H Bushing</p>	<p><b>Rails</b> 07358 - Plated Steel Channel Rails (L=9.18" x W=1.88" x H=3.00")</p>
<p><b>Pulley &amp; Sheaves</b> 01055 - 9.75" Cast Iron - 2 gr. AB 01062 - 7.75" Cast Iron - 2 gr. AB</p>	

### P470 / P490 TORQUE SPECIFICATIONS

<u>Item</u>	<u>Part #</u>	<u>Description</u>	<u>Torque Amount</u>
15A	07311	Screw with Washer	216 in.-lbs.
32	06493	Plug	110 ft.-lbs.
34	06494	Cap Screw	36 ft.-lbs.

# Specifications Model P470

	<b>U.S.</b>	<b>METRIC</b>
Volume .....	Up to 18.4 GPM .....	69.7 L/min .....
Discharge Pressure.....	Up to 2030 PSI.....	140 Bar .....
Max. Inlet Pressure .....	145 PSI .....	10 bar .....
Maximum Crankshaft Rotation Speed .....	Up to 1450 RPM	
Stroke.....	0.94" .....	24mm .....
Crankcase Oil Capacity.....	30 fl.oz.....	0.9 Liters .....
Temperature of Pumped Fluids .....	Up to 158 °F .....	70°C .....
Plunger Diameter .....	1.18" .....	30mm .....
Inlet Ports .....	(1) x 1" BSPP* & (2) x 3/4" BSPP	
Discharge Ports.....	(2) 3/4" BSPP	
Pulley Mounting.....	Either Side	
Shaft Rotation .....	Top of pulley towards fluid end	
Weight .....	39.7 lbs.....	18 kg .....

\* Recommended for inlet connection.

Consult the factory for special requirements that must be met if the pump is to operate beyond one or more of the limits specified above.

### PULLEY INFORMATION

Pulley selection and pump speed are based on a 1725 RPM motor and "B" section belts. When selecting desired GPM, allow for a ±5% tolerance on pumps output due to variations in pulleys, belts and motors among manufacturers.

1. Select GPM required, then select appropriate motor and pump pulley from the same line.
2. The desired pressure is achieved by selecting the correct nozzle size that corresponds with the pump GPM.

### HORSEPOWER INFORMATION

Horsepower ratings shown are the power requirements for the pump. Gas engine power outputs must be approximately twice the pump power requirements shown above.

We recommend that a 1.15 service factor be specified when selecting an electric motor as the power source. To compute specific pump horsepower requirements, use the following formula:

$$(GPM \times PSI) / 1450 = HP$$

<b>P470 HORSEPOWER REQUIREMENTS</b>						
<b>RPM</b>	<b>GPM</b>	<b>500 PSI</b>	<b>750 PSI</b>	<b>1000 PSI</b>	<b>1500 PSI</b>	<b>2030 PSI</b>
1000	12.7	4.4	6.6	8.8	13.1	17.8
1100	14.0	4.8	7.2	9.7	14.5	19.6
1200	15.2	5.2	7.9	10.5	15.7	21.3
1300	16.5	5.7	8.5	11.4	17.1	23.1
1450	18.4	6.3	9.5	12.7	19.0	25.8

**SPECIAL NOTE:**  
 The theoretical gallons per revolution (gal/rev) is 0.01269  
 To find specific outputs at various RPM, use the formula: GPM = 0.010743 x RPM

**NOTES:** In order to drive the pump from the side opposite the present shaft extension, simply remove the valve casing from the crankcase and rotate the pumps 180 degrees to the desired position. Be certain to rotate the seal case (item #20) as well, so that the weep holes are down at the six o'clock position. Exchange the oil fill and the oil drain plugs, also. Refer to the repair instructions as necessary for the proper assembly sequence.

# Specifications Model P490

## Continuous Ratings

	<b>U.S.</b>	<b>METRIC</b>
Volume .....	15.7 GPM .....	59.5 L/min
Discharge Pressure.....	2030 PSI.....	140 Bar
Crankshaft Speed .....		1450 RPM

## Intermittent Ratings

Volume .....	18.9 GPM .....	71.7 L/min
Discharge Pressure.....	1000 PSI.....	69 bar
Crankshaft Speed .....		1750 RPM
Max. Inlet Pressure .....	145 PSI.....	10 bar
Maximum Crankshaft Rotation Speed .....		1450 RPM
Stroke.....	0.79" .....	20mm
Crankcase Oil Capacity.....	30 fl.oz.....	0.9 Liters
Temperature of Pumped Fluids.....	Up to 158 °F .....	70°C
Plunger Diameter .....	1.18" .....	30mm
Inlet Ports .....	(1) x 1" BSPP* & (2) x 3/4" BSPP	
Discharge Ports.....	(2) 3/4" BSPP	
Pulley Mounting.....	Either Side	
Shaft Rotation .....	Top of pulley towards fluid end	
Weight .....	39.7lbs.....	18 kg

\* Recommend using this for inlet connection.

Consult the factory for special requirements that must be met if the pump is to operate beyond one or more of the limits specified above.

### PULLEY INFORMATION

Pulley selection and pump speed are based on a 1725 RPM motor and "B" section belts. When selecting desired GPM, allow for a ±5% tolerance on pumps output due to variations in pulleys, belts and motors among manufacturers.

1. Select GPM required, then select appropriate motor and pump pulley from the same line.
2. The desired pressure is achieved by selecting the correct nozzle size that corresponds with the pump GPM.

### HORSEPOWER INFORMATION

Horsepower ratings shown are the power requirements for the pump. Gas engine power outputs must be approximately twice the pump power requirements shown above.

We recommend that a 1.15 service factor be specified when selecting an electric motor as the power source. To compute specific pump horsepower requirements, use the following formula:

$$(GPM \times PSI) / 1450 = HP$$

<b>P490 HORSEPOWER REQUIREMENTS</b>						
<b>RPM</b>	<b>GPM</b>	<b>500 PSI</b>	<b>750 PSI</b>	<b>1000 PSI</b>	<b>1500 PSI</b>	<b>2030 PSI</b>
1000	10.8	3.7	5.6	7.4	11.2	15.1
1200	13.0	4.5	6.7	9.0	13.4	18.2
1300	14.0	4.8	7.2	9.7	14.5	19.6
1450	15.7	5.4	8.1	10.8	16.2	22.0
1750	18.9	6.5	9.8	13.0	19.6	26.5

**NOTES:** In order to drive the pump from the side opposite the present shaft extension, simply remove the valve casing from the crankcase and rotate the pumps 180 degrees to the desired position. Be certain to rotate the seal case (item #20) as well, so that the weep holes are down at the six o'clock position. Exchange the oil fill and the oil drain plugs, also. Refer to the repair instructions as necessary for the proper assembly sequence.

**SPECIAL NOTE:**  
The theoretical gallons per revolution (gal/rev) is 0.010743  
To find specific outputs at various RPM, use the formula:  
GPM = 0.010743 x RPM





## P470 / P490 PARTS LIST

<u>ITEM</u>	<u>PART</u>	<u>DESCRIPTION</u>	<u>QTY.</u>	<u>ITEM</u>	<u>PART</u>	<u>DESCRIPTION</u>	<u>QTY.</u>
1	08377	Crankcase	1	16D	08399	Tension Screw	3
2	08378	Oil Fill Plug with Gasket	1	16E	07023	O-Ring	3
3	06479	Crankcase Cover	1	16F	07203	Support Ring	3
3A	07186	Oil Sight Glass w/Gasket	1	16G	07258	Copper Gasket	3
4	08380	O-Ring	1	17	06790	Crosshead Pin	3
5	07109	Oil Drain Plug	1	19	08366	Oil Seal	3
5A	07182	Gasket for Oil Drain Plug	1	20	06928	Seal Adapter	3
5B	08092	Plug with Gasket	1	20A	08059	O-Ring	3
6	01010	Screw	4	21	06929	Seal Case	3
6A	01011-0400	Spring Washer	4	21A	07150	O-Ring	6
7	05290	Bearing Cover	1	22	06930	Valve Holder	3
8	05291	Bearing Cover	1	23	06931	Grooved Seal	6
8A	05292	Shim	1-3	24	06932	Support Ring	3
8B	05293	Shim	1	25	06933	Intermediate Casing	1
9	06925	O-Ring	2	25A	05934	Thread Plug	2
10	07114	Screw with Washer	8	25B	02009	O-Ring	2
11	07459	Radial Shaft Seal	1	26	06935	Valve Casing	1
12	085352	Bearing	2	27	06937	Valve Seat	6
13	08475	Crankshaft (P470)	1	27A	06936	Valve Assembly	6
13	08482	Crankshaft (P490)	1	28	06938	Valve Plate	6
14	08091	Fitting Key	1	29	06377-0100	Valve Spring	6
15	08390	Connecting Rod Assy.	3	30	06939	Valve Spring Retainer	6
16	05933	Plunger Assy.	3	31	07212	O-Ring	6
16A	05352	Plunger	3	32	08373	Plug	3
16B	06927	Plunger Pipe	3	33	07214	O-Ring	3
15B	05249	Connecting Red Screw	3	34	06494	Cap Screw	8
15C	05348	Adapter Sleeve	3	36	07703	Plug, 3/8" BSP	3

## P470 / P490 REPAIR KITS

### Plunger Packing Kit, #09565

<u>Item</u>	<u>Part #</u>	<u>Description</u>	<u>Qty.</u>
20A	08059	O-Ring	3
21A	07150	O-Ring	6
23	06931	Grooved Seal	6
24	06932	Support Ring	3
25B	02009	O-Ring	2

### Valve Assembly Kit, #09566

<u>Item</u>	<u>Part #</u>	<u>Description</u>	<u>Qty.</u>
27A	06936	Valve Assembly	6
31	07212	O-Ring	6
33	07214	O-Ring	3

### Oil Seal Kit, #09306

<u>Item</u>	<u>Part #</u>	<u>Description</u>	<u>Qty.</u>
19	08366	Oil Seal	3

# REPAIR INSTRUCTIONS - P470 / P490 PUMPS

## To Check Valves

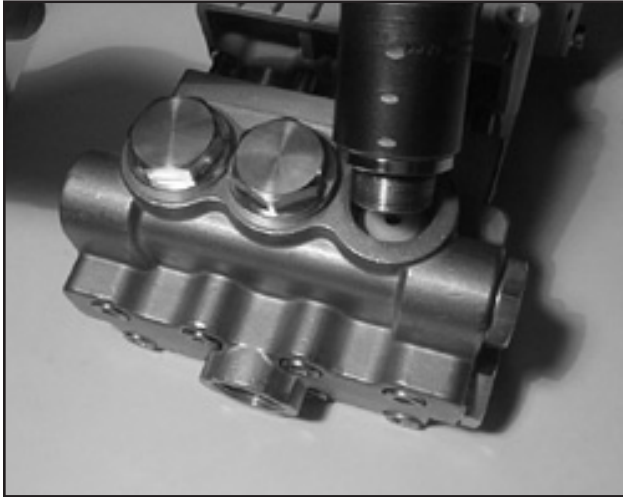

1. Remove plugs (32) with socket wrench.

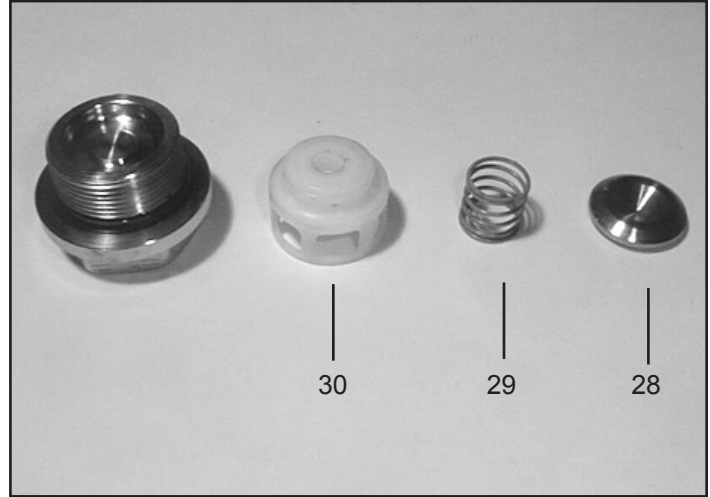

2. Remove the exposed spring tension cap (30) from valve seat by pushing it sideways with a screwdriver. Remove spring tension cap (30), valve spring (29), and valve plate (28).

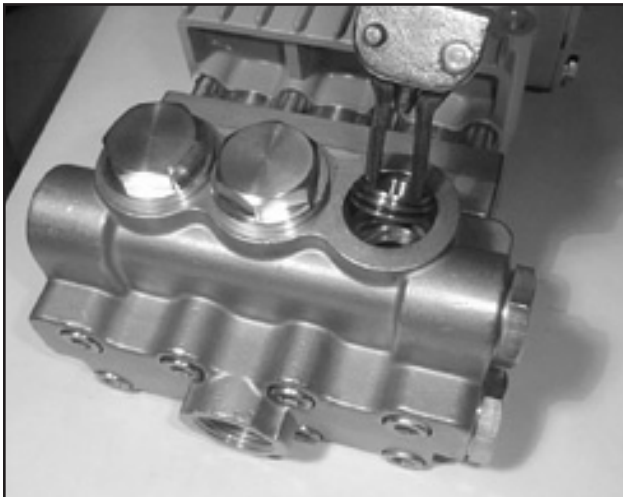

3. Pull out valve seat (27) and O-ring (31) with a valve puller. Check O-ring for wear.

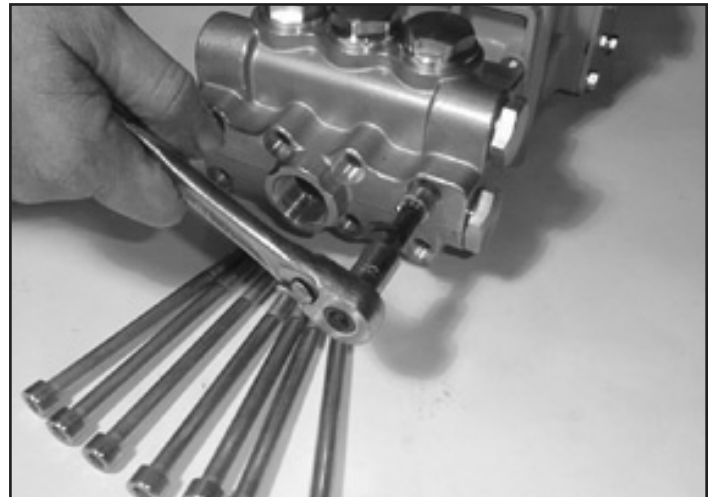

4. Remove hexagon socket screws (34) and remove valve casing (26) by pulling them front-wise over the plungers (16).



# REPAIR INSTRUCTIONS - P470 / P490 PUMPS

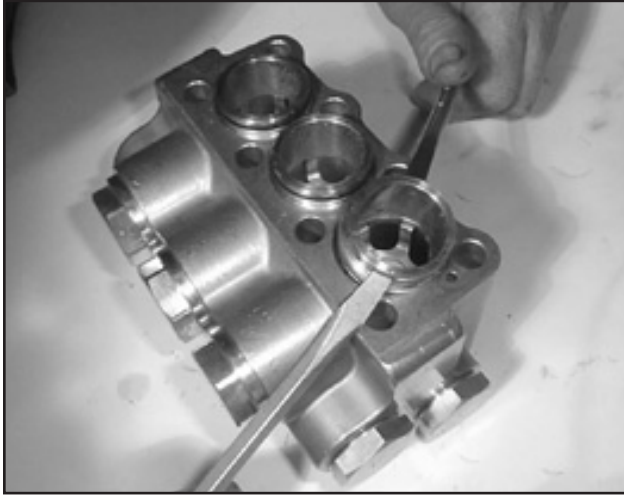

5. Using two screwdrivers, remove seal case (21) out of the valve casing (26) or intermediate casing (25).

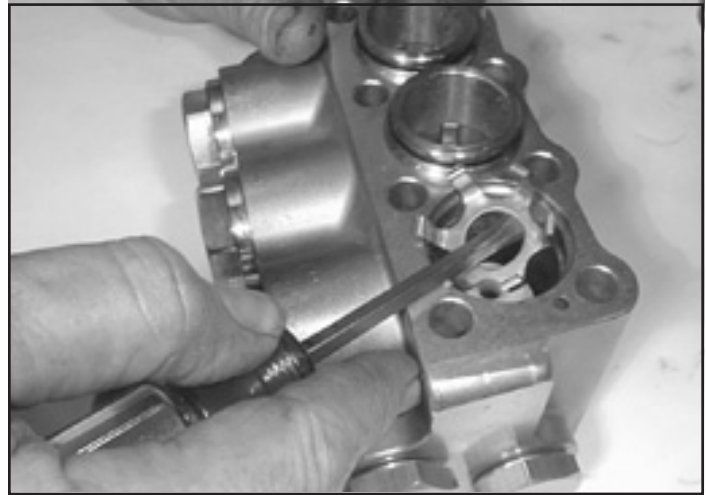

6. The exposed suction valve parts are to be removed the same way as the discharge valves as described above. Check valve components for wear and damage. Check O-rings (21A, 31, 33). Replace worn parts. Reassemble in same order. Coat new o-rings with oil before installation. Coat O-rings (25B) with silicon grease and place them in their recesses. Insert seal cases (21) into valve casing (26) before mounting the whole unit. Slide valve casing (26) over plungers. Tighten hexagon socket screws (34) crosswise and evenly at 36 ft-lbs. Tighten plugs (32) at 107 ft-lbs.

**Important:** When extracting the valve holders (22), make sure not to scratch the outer bore diameter as this is a sealing.

## To Check To Check Seals and Plunger Pipe

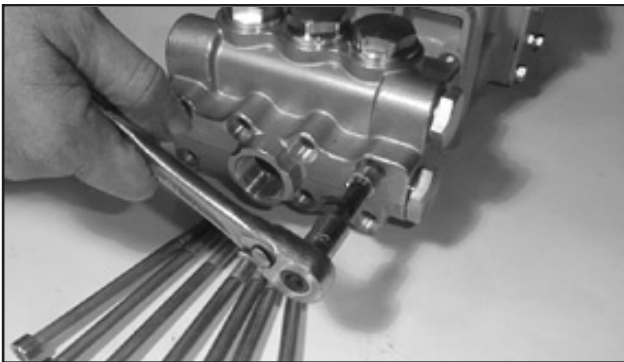

7. Remove hexagon socket screws (34) and remove valve casing (26) by pulling them frontwise over the plungers (16).



8. Using two screwdrivers, gently pry seal cases (21) out of the valve casing (26) or intermediate casing (25). Press grooved rings (23) and support rings (24) out of intermediate casing (25) using a screwdriver. Check O-rings (21A/25B). Examine seals (23). Replace worn seals.

# REPAIR INSTRUCTIONS - P470 / P490 PUMPS

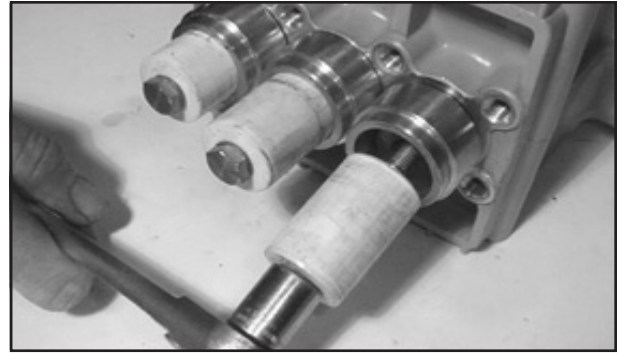
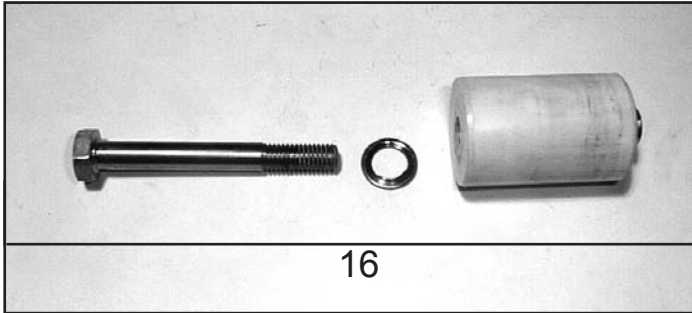

9. Check plunger surfaces (16). Damaged surfaces lead to accelerated seal wear. Deposits of all kinds must be removed from the plungers.

**Important:** Plunger surfaces are not to be damaged. If there are lime deposits in the pump, care must be taken that the weep-return bore in parts (25) and (26) ensure trouble-free weep-return.

10. If the plunger pipe (16B) is worn, remove tension screw (16D) and remove together with plunger pipe. Check and clean plunger (16A) surfaces and mount new plunger pipe. Cover thread of tension screw (16D) with a thin film of Loctite and tighten carefully at 26 ft-lbs.

**Important:** Glue must never come between the plunger pipe (16B) and the centring sleeve (16C). The plunger pipe is not to be strained by eccentric tightening of the tension screw or through damage to the front surface as this can lead to breakage.

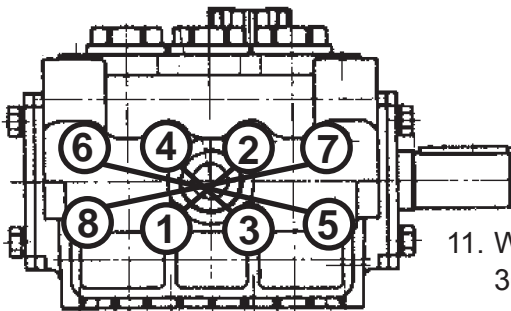

11. When reassembling, tighten inner hexagon screw (34) at 36 ft-lbs. in a crossing pattern (as shown on left).

## Gear and Plunger

If oil leaks where the plungers (16) protrude out of the gear, gear seals (19) and plungers must be examined and replaced if necessary.

- a) **Gear Seal:** Remove oil plug (5) and drain oil. Remove valve casing (26) together with seal casing (25) as described above. Dismantle plunger pipe (16B). Pry gear seal adaptor (20) out of the crankcase using a screwdriver; take out gear seal (19) and replace it.
- b) **Plungers:** Remove oil plug (5) and drain oil; remove crankcase cover (3). Remove valve casing (26), seal casing (25), gear seal adaptors (20) and plunger pipes (16B) as described above. Remove screws on conn-rods (15). Be careful not to mix up the connecting rod halves. Push connecting rod shaft as far as possible into the crosshead guide. Take off screws (10) and pry out bearing covers (7 & 8) with the help of a screwdriver. Take out crankshaft carefully threading it past the conrods (15), making sure not to bend the connecting rods. Remove and dismantle connecting rods and plungers (16). Replace worn parts. Reassemble and tighten tension screws (16D) at 26 ft-lbs. When reinstalling, first insert connecting rods together with plungers. Thread in crankshaft. Then push bearing covers (7 & 8) onto the crankshaft ends. Screw on bearing covers with screws (10). Mount connecting rod halves and tighten screws (15) at 22 ft-lbs. Mount crankcase cover (3) together with O-ring (4). Replace seal adaptors (20), seal casing (25) and valve casing (26). Replace eight (8) hexagon screws (34) and tighten to 36 lb-ft.

**MODEL P470 / P490 DIMENSIONS - INCHES (mm)**

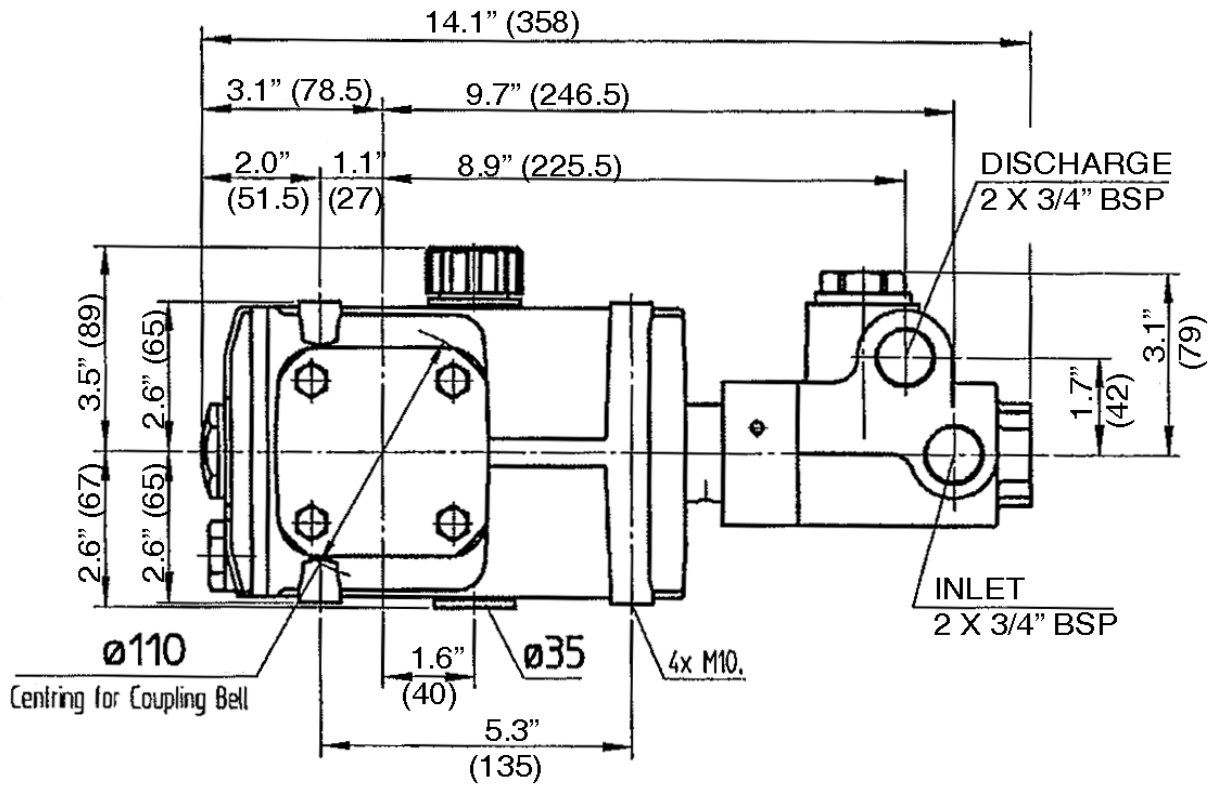
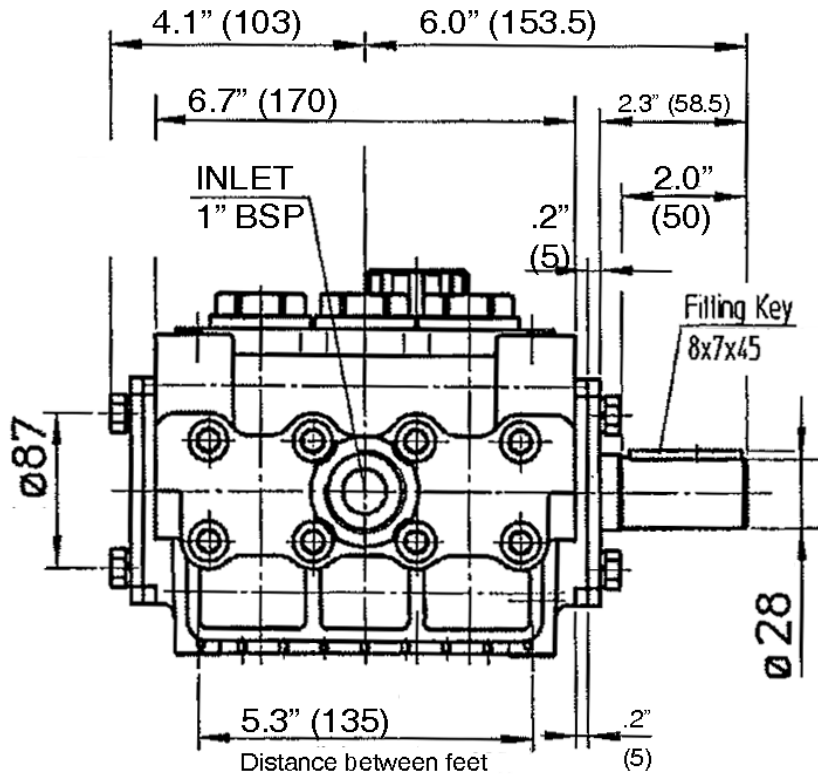

## GIANT INDUSTRIES LIMITED WARRANTY

Giant Industries, Inc. pumps and accessories are warranted by the manufacturer to be free from defects in workmanship and material as follows:

1. For portable pressure washers and self-service car wash applications, the discharge manifolds are guaranteed for the life of the pump. Our other pump parts, used in portable pressure washers and in car wash applications, are warranted for five years from the date of shipment for all pumps used in NON-SALINE, clean water applications.
2. One (1) year from the date of shipment for all other Giant industrial and consumer pumps.
3. Six (6) months from the date of shipment for all rebuilt pumps.
4. Ninety (90) days from the date of shipment for all Giant accessories.

This warranty is limited to repair or replacement of pumps and accessories of which the manufacturer's evaluation shows were defective at the time of shipment by the manufacturer. The following items are NOT covered or will void the warranty:

1. Defects caused by negligence or fault of the buyer or third party.
2. Normal wear and tear to standard wear parts.
3. Use of repair parts other than those manufactured or authorized by Giant.
4. Improper use of the product as a component part.
5. Changes or modifications made by the customer or third party.
6. The operation of pumps and or accessories exceeding the specifications set forth in the Operations Manuals provided by Giant Industries, Inc.

Liability under this warranty is on all non-wear parts and limited to the replacement or repair of those products returned freight prepaid to Giant Industries which are deemed to be defective due to workmanship or failure of material. A Returned Goods Authorization (R.G.A.) number and completed warranty evaluation form is required prior to the return to Giant Industries of all products under warranty consideration. Call (419)-531-4600 or fax (419)-531-6836 to obtain an R.G.A. number.

Repair or replacement of defective products as provided is the sole and exclusive remedy provided hereunder and the MANUFACTURER SHALL NOT BE LIABLE FOR FURTHER LOSS, DAMAGES, OR EXPENSES, INCLUDING INCIDENTAL AND CONSEQUENTIAL DAMAGES DIRECTLY OR INDIRECTLY ARISING FROM THE SALE OR USE OF THIS PRODUCT.

THE LIMITED WARRANTY SET FORTH HEREIN IS IN LIEU OF ALL OTHER WARRANTIES OR REPRESENTATION, EXPRESS OR IMPLIED, INCLUDING WITHOUT LIMITATION ANY WARRANTIES OR MERCHANTABILITY OR FITNESS FOR A PARTICULAR PURPOSE AND ALL SUCH WARRANTIES ARE HEREBY DISCLAIMED AND EXCLUDED BY THE MANUFACTURER.

