

# Series P200-12mm versions

Triplex Ceramic  
Plunger Pump  
Operating Instructions/  
Repair and Service  
Manual



P205  
P206  
P207  
P208  
P209  
P210  
P211



## Contents:

Installation Instructions:	page 2
Pump Specifications:	pages 3-9
Exploded View:	page 10
Parts List:	page 11
Kits & Torque Specifications:	page 12
Pump Mounting Selection Guide:	page 12
Repair Instructions:	pages 13-14
Recommended Spare Parts List:	page 14
Dimensions:	page 15
Warranty Information:	back page

# INSTALLATION INSTRUCTIONS

**Installation of the Giant Industries, Inc., pump is not a complicated procedure, but there are some basic steps common to all pumps. The following information is to be considered as a general outline for installation. If you have unique requirements, please contact Giant Industries, Inc. or your local distributor for assistance.**

1. The pump should be installed flat on a base to a maximum of a 15 degree angle of inclination to ensure optimum lubrication.
2. The inlet to the pump should be sized for the flow rate of the pump with no unnecessary restrictions that can cause cavitation. Teflon tape should be used to seal all joints. If pumps are to be operated at temperatures in excess of 160° F, it is important to insure a positive head to the pump to prevent cavitation.
3. The discharge plumbing from the pump should be properly sized to the flow rate to prevent line pressure loss to the work area. It is essential to provide a safety bypass valve between the pump and the work area to protect the pump from pressure spikes in the event of a blockage or the use of a shut-off gun.

4. Use of a dampener is necessary to minimize pulsation at drive elements, plumbing, connections, and other system areas. The use of a dampener with Giant Industries, Inc. pumps is optional, although recommended by Giant Industries, Inc. to further reduce system pulsation. Dampeners can also reduce the severity of pressure spikes that occur in systems using a shut-off gun. A dampener must be positioned downstream from the unloader.

5. Crankshaft rotation on Giant Industries, Inc. pumps should be made in the direction designated by the arrows on the pump crankcase. Reverse rotation may be safely achieved by following a few guidelines available upon request from Giant Industries, Inc. Required horsepower for system operation can be obtained from the charts on pages 3-9.

6. Before beginning operation of your pumping system, remember: Check that the crankcase and seal areas have been properly lubricated per recommended schedules. Do not run the pump dry for extended periods of time. Cavitation will result in severe damage. Always remember to check that all plumbing valves are open and that pumped media can flow freely to the inlet of the pump.

Finally, remember that high pressure operation in a pump system has many advantages. But, if it is used carelessly and without regard to its potential hazard, it can cause serious injury.

## IMPORTANT OPERATING CONDITIONS

**Failure to comply with any of these conditions invalidates the warranty.**

1. Prior to initial operation, add oil to the crankcase so that oil level is between the two lines on the oil dipstick. **DO NOT OVERFILL.**

### **Use Giant 20W-50 oil (p/n 01153)**

Crankcase oil should be changed after the first 50 hours of operation, then at regular intervals of 500 hours or less depending on operating conditions.

2. Pump operation must not exceed rated pressure, volume, or RPM. A pressure relief device must be installed in the discharge of the system.

3. Acids, alkalines, or abrasive fluids cannot be pumped unless approval in writing is obtained before operation from Giant Industries, Inc.

4. Run the pump dry approximately 10 seconds to drain the water before exposure to freezing temperatures.

# Specifications

## Model P205

<b>1750 RPM<sup>+</sup></b> .....	<b>U. .S.</b>	<b>Metric</b>
Flow (Continuous) @ 2000 PSI (140 Bar) .....	0.5 GPM .....	1.9 LPM
Flow (Intermittent) @ 2500 PSI (175 Bar) .....	0.5 GPM .....	1.9 LPM
<b>3450 RPM<sup>+</sup></b>		
Flow (Continuous) @ 2000 PSI (140 Bar) .....	0.9 GPM .....	2.4 LPM
Flow (Intermittent) @ 2000 PSI (140 Bar) .....	0.9 GPM .....	2.4 LPM
Maximum Inlet Pressure .....	145 PSI .....	10 Bar
Plunger Diameter .....	0.47" .....	12 mm
Stroke .....	0.13" .....	3.4 mm
Max. Temperature of Pumped Fluids .....	160° F .....	70° C
Inlet Ports .....	(2) 1/2" BSP	
Discharge Ports .....	(2) 3/8" BSP	
Shaft Rotation .....	Top of Pulley Towards Fluid End	
Crankshaft Diameter .....	0.98" .....	24 mm
Key Width .....	0.31" .....	8 mm
Shaft Mounting .....	Right Side Facing Manifold	
Weight .....	11.7 lbs. ....	5.3 Kg
Crankcase Oil Capacity .....	7.5 fl.oz. ....	0.22 Liters
Extended Crankcase Oil Capacity .....	9.0 fl.oz. ....	0.27 Liters
Volumetric Efficiency @ 1750 RPM .....	0.94	
Volumetric Efficiency @ 3450 RPM .....	0.87	
Mechanical Efficiency @ 3450 RPM .....	0.86	

<sup>+</sup>Positive inlet pressure required

Consult the factory for special requirements that must be met if the pump is to operate beyond one or more of the limits specified above.

**NOTE:**

**In order to drive the pump from the side opposite the present shaft extension, simply remove the valve casing from the crankcase and rotate the pumps 180 degrees to the desired position. Be certain to rotate the seal case (item #20) as well, so that the weep holes are down at the six o'clock position. Exchange the oil fill and the oil drain plugs, also. Refer to the repair instructions as necessary for the proper assembly sequence.**

<b>P205 HORSEPOWER REQUIREMENTS</b>					
<b>RPM</b>	<b>GPM</b>	<b>1000 PSI</b>	<b>1500 PSI</b>	<b>2000 PSI</b>	<b>2500 PSI*</b>
500	0.13	0.1	0.1	0.2	0.2
1000	0.29	0.2	0.3	0.4	0.5
1750	0.50	0.3	0.5	0.7	0.9
3000	0.78	0.5	0.8	1.1	1.4
3200	0.84	0.6	0.9	1.2	1.4
3450	0.90	0.6	0.9	1.2	1.6

\*intermittent duty

**HORSEPOWER RATINGS:**

The rating shown are the power requirements for the pump. Gas engine power outputs must be approximately twice the pump power requirements shown above.

We recommend a 1.15 service factor be specified when selecting an electricmotor as the power source.

To compute specific pump horse power requirements, use the following formula:

$$HP = (GPM \times PSI) / 1450$$

# Specifications

## Model P206

<b>1750 RPM<sup>+</sup></b> .....	<b>U. .S.</b>	<b>Metric</b>
Flow (Continuous) @ 2000 PSI (140 Bar) .....	0.8 GPM .....	3.0 LPM
Flow (Intermittent) @ 2500 PSI (175 Bar) .....	0.8 GPM .....	3.0 LPM
<b>3450 RPM<sup>+</sup></b>		
Flow (Continuous) @ 2000 PSI (140 Bar) .....	1.5 GPM .....	5.7 LPM
Flow (Intermittent) @ 2000 PSI (140 Bar) .....	1.5 GPM .....	5.7 LPM
Maximum Inlet Pressure .....	145 PSI .....	10 Bar
Plunger Diameter .....	0.47" .....	12 mm
Stroke .....	0.22" .....	5.5 mm
Max. Temperature of Pumped Fluids .....	160° F .....	70° C
Inlet Ports .....	(2) 1/2" BSP	
Discharge Ports .....	(2) 3/8" BSP	
Shaft Rotation .....	Top of Pulley Towards Fluid End	
Crankshaft Diameter .....	0.98" .....	24 mm
Key Width .....	0.31" .....	8 mm
Shaft Mounting .....	Right Side Facing Manifold	
Weight .....	11.7 lbs. ....	5.3 Kg
Crankcase Oil Capacity .....	7.5 fl.oz. ....	0.22 Liters
Extended Crankcase Oil Capacity .....	9.0 fl.oz. ....	0.27 Liters
Volumetric Efficiency @ 1750 RPM .....	0.94	
Volumetric Efficiency @ 3450 RPM .....	0.87	
Mechanical Efficiency @ 3450 RPM .....	0.86	

<sup>+</sup>Positive inlet pressure required

Consult the factory for special requirements that must be met if the pump is to operate beyond one or more of the limits specified above.

**NOTE:**

**In order to drive the pump from the side opposite the present shaft extension, simply remove the valve casing from the crankcase and rotate the pumps 180 degrees to the desired position. Be certain to rotate the seal case (item #20) as well, so that the weep holes are down at the six o'clock position. Exchange the oil fill and the oil drain plugs, also. Refer to the repair instructions as necessary for the proper assembly sequence.**

<b>P206 HORSEPOWER REQUIREMENTS</b>					
<b>RPM</b>	<b>GPM</b>	<b>1000 PSI</b>	<b>1500 PSI</b>	<b>2000 PSI</b>	<b>2500 PSI*</b>
250	0.11	0.1	0.1	0.2	0.2
500	0.21	0.1	0.2	0.3	0.4
1000	0.43	0.3	0.4	0.6	0.7
1750	0.76	0.5	0.8	1.0	1.3
3000	1.30	0.9	1.3	1.8	2.2
3200	1.40	1.0	1.4	1.9	2.4
3450	1.50	1.0	1.6	2.1	2.6

\*Intermittent duty only

**HORSEPOWER RATINGS:**

The rating shown are the power requirements for the pump. Gas engine power outputs must be approximately twice the pump power requirements shown above.

We recommend a 1.15 service factor be specified when selecting an electric motor as the power source. To compute specific pump horse power requirements, use the following formula:

$$HP = (GPM \times PSI) / 1450$$

# Specifications

## Model P207

1750 RPM <sup>+</sup>	U. .S.	Metric
Flow (Continuous) @ 2000 PSI (140 Bar)	0.9 GPM	3.4 LPM
Flow (Intermittent) @ 2500 PSI (175 Bar)	0.9 GPM	3.4 LPM
3450 RPM <sup>+</sup>		
Flow (Continuous) @ 2000 PSI (140 Bar)	1.7 GPM	6.4 LPM
Flow (Intermittent) @ 2000 PSI (140 Bar)	1.7 GPM	6.4 LPM
Maximum Inlet Pressure	145 PSI	10 Bar
Plunger Diameter	0.47"	12 mm
Stroke	0.25"	6.3 mm
Max. Temperature of Pumped Fluids	160° F	70° C
Inlet Ports		(2) 1/2" BSP
Discharge Ports		(2) 3/8" BSP
Shaft Rotation		Top of Pulley Towards Fluid End
Crankshaft Diameter	0.98"	24 mm
Key Width	0.31"	8 mm
Shaft Mounting		Right Side Facing Manifold
Weight	11.7 lbs.	5.3 Kg
Crankcase Oil Capacity	7.5 fl.oz.	0.22 Liters
Extended Crankcase Oil Capacity	9.0 fl.oz.	0.27 Liters
Volumetric Efficiency @ 1750 RPM		0.94
Volumetric Efficiency @ 3450 RPM		0.87
Mechanical Efficiency @ 3450 RPM		0.86

<sup>+</sup>Positive inlet pressure required

Consult the factory for special requirements that must be met if the pump is to operate beyond one or more of the limits specified above.

**NOTE:**

**In order to drive the pump from the side opposite the present shaft extension, simply remove the valve casing from the crankcase and rotate the pumps 180 degrees to the desired position. Be certain to rotate the seal case (item #20) as well, so that the weep holes are down at the six o'clock position. Exchange the oil fill and the oil drain plugs, also. Refer to the repair instructions as necessary for the proper assembly sequence.**

<b>P207 HORSEPOWER REQUIREMENTS</b>					
RPM	GPM	1000 PSI	1500 PSI	2000 PSI	2500 PSI*
500	0.26	0.2	0.3	0.4	0.4
1000	0.51	0.4	0.5	0.7	0.9
1750	0.90	0.6	0.9	1.2	1.6
3000	1.48	1.0	1.5	2.0	2.6
3200	1.58	1.1	1.6	2.2	2.7
3450	1.70	1.2	1.8	2.3	2.9

\*Intermittent duty only

**HORSEPOWER RATINGS:**

The rating shown are the power requirements for the pump. Gas engine power outputs must be approximately twice the pump power requirements shown above.

We recommend a 1.15 service factor be specified when selecting an electric motor as the power source. To compute specific pump horse power requirements, use the following formula:

$$HP = (GPM \times PSI) / 1450$$

# Specifications

## Model P208

<b>1750 RPM+</b>	<b>U. S.</b>	<b>Metric</b>
Flow (Continuous) @ 2000 PSI (140 Bar) .....	1.0 GPM .....	3.8 LPM
Flow (Intermittent) @ 2500 PSI (175 Bar) .....	1.0 GPM .....	3.8 LPM
<b>3450 RPM+</b>		
Flow (Continuous) @ 2000 PSI (140 Bar) .....	1.9 GPM .....	7.2 LPM
Flow (Intermittent) @ 2000 PSI (140 Bar) .....	1.9 GPM .....	7.2 LPM
Maximum Inlet Pressure .....	145 PSI .....	10 Bar
Plunger Diameter .....	0.47" .....	12 mm
Stroke .....	0.28" .....	7 mm
Max. Temperature of Pumped Fluids .....	160° F.....	70° C
Inlet Ports.....		(2) 1/2" BSP
Discharge Ports .....		(2) 3/8" BSP
Shaft Rotation .....	Top of Pulley Towards Fluid End	
Crankshaft Diameter .....	0.98" .....	24 mm
Key Width .....	0.31" .....	8 mm
Shaft Mounting .....	Right Side Facing Manifold	
Weight .....	11.7 lbs. ....	5.3 Kg
Crankcase Oil Capacity .....	7.5 fl.oz. ....	0.22 Liters
Extended Crankcase Oil Capacity .....	9.0 fl.oz. ....	0.27 Liters
Volumetric Efficiency @ 1750 RPM .....		0.94
Volumetric Efficiency @ 3450 RPM .....		0.87
Mechanical Efficiency @ 3450 RPM .....		0.86

+Positive inlet pressure required

Consult the factory for special requirements that must be met if the pump is to operate beyond one or more of the limits specified above.

**NOTE:**

**In order to drive the pump from the side opposite the present shaft extension, simply remove the valve casing from the crankcase and rotate the pumps 180 degrees to the desired position. Be certain to rotate the seal case (item #20) as well, so that the weep holes are down at the six o'clock position. Exchange the oil fill and the oil drain plugs, also. Refer to the repair instructions as necessary for the proper assembly sequence.**

<b>P208 HORSEPOWER REQUIREMENTS</b>					
<b>RPM</b>	<b>GPM</b>	<b>1000 PSI</b>	<b>1500 PSI</b>	<b>2000 PSI</b>	<b>2500 PSI*</b>
250	0.14	0.1	0.1	0.2	0.2
500	0.29	0.2	0.3	0.4	0.5
1000	0.57	0.4	0.6	0.8	1.0
1750	1.00	0.7	1.0	1.4	1.7
3000	1.60	1.1	1.7	2.2	2.8
3200	1.80	1.2	1.9	2.5	3.1
3450	1.90	1.3	2.0	2.6	3.3

\*Intermittent duty only

**HORSEPOWER RATINGS:**

The rating shown are the power requirements for the pump. Gas engine power outputs must be approximately twice the pump power requirements shown above.

We recommend a 1.15 service factor be specified when selecting an electric motor as the power source. To compute specific pump horse power requirements, use the following formula:

$$HP = (GPM \times PSI) / 1450$$



# Specifications Model P209

	U. .S.	Metric
1750 RPM <sup>+</sup> .....		
Flow (Continuous) @ 2000 PSI (140 Bar) .....	1.5 GPM	5.7 LPM
Flow (Intermittent) @ 2500 PSI (175 Bar) .....	1.5 GPM	5.7 LPM
3450 RPM <sup>+</sup>		
Flow (Continuous) @ 2000 PSI (140 Bar) .....	2.7 GPM	10.2 LPM
Flow (Intermittent) @ 2000 PSI (140 Bar) .....	2.7 GPM	10.2 LPM
Maximum Inlet Pressure .....	145 PSI	10 Bar
Plunger Diameter .....	0.47"	12 mm
Stroke .....	0.39"	10 mm
Max. Temperature of Pumped Fluids .....	160° F	70° C
Inlet Ports .....		(2) 1/2" BSP
Discharge Ports .....		(2) 3/8" BSP
Shaft Rotation .....	Top of Pulley Towards Fluid End	
Crankshaft Diameter .....	0.98"	24 mm
Key Width .....	0.31"	8 mm
Shaft Mounting .....	Right Side Facing Manifold	
Weight .....	11.7 lbs.	5.3 Kg
Crankcase Oil Capacity .....	7.5 fl.oz.	0.22 Liters
Extended Crankcase Oil Capacity .....	9.0 fl.oz.	0.27 Liters
Volumetric Efficiency @ 1750 RPM .....	0.94	
Volumetric Efficiency @ 3450 RPM .....	0.87	
Mechanical Efficiency @ 3450 RPM .....	0.86	

<sup>+</sup>Positive inlet pressure required

Consult the factory for special requirements that must be met if the pump is to operate beyond one or more of the limits specified above.

**NOTE:**

**In order to drive the pump from the side opposite the present shaft extension, simply remove the valve casing from the crankcase and rotate the pumps 180 degrees to the desired position. Be certain to rotate the seal case (item #20) as well, so that the weep holes are down at the six o'clock position. Exchange the oil fill and the oil drain plugs, also. Refer to the repair instructions as necessary for the proper assembly sequence.**

<b>P209 HORSEPOWER REQUIREMENTS</b>					
RPM	GPM	1000 PSI	1500 PSI	2000 PSI	2500 PSI*
500	0.43	0.3	0.4	0.6	0.7
1000	0.86	0.6	0.9	1.2	1.5
1750	1.50	1.0	1.6	2.1	2.6
3000	2.35	1.6	2.4	3.2	4.0
3200	2.50	1.7	2.6	3.4	4.3
3450	2.70	1.9	2.8	3.7	4.7

\*Intermittent duty only

**HORSEPOWER RATINGS:**

The rating shown are the power requirements for the pump. Gas engine power outputs must be approximately twice the pump power requirements shown above.

We recommend a 1.15 service factor be specified when selecting an electricmotor as the power source. To compute specific pump horse power requirements, use the following formula:

$$HP = (GPM \times PSI) / 1450$$

# Specifications Model P210

<b>1750 RPM<sup>+</sup></b> .....	<b>U. .S.</b>	<b>Metric</b>
Flow (Continuous) @ 2000 PSI (140 Bar) .....	1.8 GPM .....	6.8 LPM
Flow (Intermittent) @ 2500 PSI (175 Bar) .....	1.8 GPM .....	6.8 LPM
<b>3450 RPM<sup>+</sup></b>		
Flow (Continuous) @ 2000 PSI (140 Bar) .....	3.3 GPM .....	12.5 LPM
Flow (Intermittent) @ 2000 PSI (140 Bar) .....	3.3 GPM .....	12.5 LPM
Maximum Inlet Pressure .....	145 PSI .....	10 Bar
Plunger Diameter .....	0.47" .....	12 mm
Stroke .....	0.49" .....	12.4 mm
Max. Temperature of Pumped Fluids .....	160° F .....	70° C
Inlet Ports .....	(2) 1/2" BSP	
Discharge Ports .....	(2) 3/8" BSP	
Shaft Rotation .....	Top of Pulley Towards Fluid End	
Crankshaft Diameter .....	0.98" .....	24 mm
Key Width .....	0.31" .....	8 mm
Shaft Mounting .....	Right Side Facing Manifold	
Weight .....	11.7 lbs. ....	5.3 Kg
Crankcase Oil Capacity .....	7.5 fl.oz. ....	0.22 Liters
Extended Crankcase Oil Capacity .....	9.0 fl.oz. ....	0.27 Liters
Volumetric Efficiency @ 1750 RPM .....	0.94	
Volumetric Efficiency @ 3450 RPM .....	0.87	
Mechanical Efficiency @ 3450 RPM .....	0.86	

<sup>+</sup>Positive inlet pressure required

Consult the factory for special requirements that must be met if the pump is to operate beyond one or more of the limits specified above.

**NOTE:**

**In order to drive the pump from the side opposite the present shaft extension, simply remove the valve casing from the crankcase and rotate the pumps 180 degrees to the desired position. Be certain to rotate the seal case (item #20) as well, so that the weep holes are down at the six o'clock position. Exchange the oil fill and the oil drain plugs, also. Refer to the repair instructions as necessary for the proper assembly sequence.**

<b>P210 HORSEPOWER REQUIREMENTS</b>					
<b>RPM</b>	<b>GPM</b>	<b>1000 PSI</b>	<b>1500 PSI</b>	<b>2000 PSI</b>	<b>2500 PSI*</b>
250	0.26	0.2	0.3	0.4	0.4
500	0.51	0.4	0.5	0.7	0.9
1000	1.03	0.7	1.1	1.4	1.8
1750	1.80	1.2	1.9	2.5	3.1
3000	2.87	2.0	3.0	4.0	5.0
3200	3.06	2.1	3.2	4.2	5.3
3450	3.30	2.3	3.4	4.6	5.7

\*Intermittent duty only

**HORSEPOWER RATINGS:**

The rating shown are the power requirements for the pump. Gas engine power outputs must be approximately twice the pump power requirements shown above.

We recommend a 1.15 service factor be specified when selecting an electric motor as the power source. To compute specific pump horse power requirements, use the following formula:

$$HP = (GPM \times PSI) / 1450$$



# Specifications

## Model P211

<b>1750 RPM<sup>+</sup></b> .....	<b>U. .S.</b>	<b>Metric</b>
Flow (Continuous) @ 2000 PSI (140 Bar) .....	2.1 GPM .....	7.9 LPM
Flow (Intermittent) @ 2500 PSI (175 Bar) .....	2.1 GPM .....	7.9 LPM
<b>3450 RPM<sup>+</sup></b>		
Flow (Continuous) @ 2000 PSI (140 Bar) .....	3.8 GPM .....	14.4 LPM
Flow (Intermittent) @ 2000 PSI (140 Bar) .....	3.8 GPM .....	14.4 LPM
Maximum Inlet Pressure .....	145 PSI .....	10 Bar
Plunger Diameter .....	0.47" .....	12 mm
Stroke .....	0.56" .....	14.2 mm
Max. Temperature of Pumped Fluids .....	160° F .....	70° C
Inlet Ports .....		(2) 1/2" BSP
Discharge Ports .....		(2) 3/8" BSP
Shaft Rotation .....	Top of Pulley Towards Fluid End	
Crankshaft Diameter .....	0.98" .....	24 mm
Key Width .....	0.31" .....	8 mm
Shaft Mounting .....	Right Side Facing Manifold	
Weight .....	11.7 lbs. ....	5.3 Kg
Crankcase Oil Capacity .....	7.5 fl.oz. ....	0.22 Liters
Extended Crankcase Oil Capacity .....	9.0 fl.oz. ....	0.27 Liters
Volumetric Efficiency @ 1750 RPM .....		0.94
Volumetric Efficiency @ 3450 RPM .....		0.87
Mechanical Efficiency @ 3450 RPM .....		0.86

<sup>+</sup>Positive inlet pressure required

Consult the factory for special requirements that must be met if the pump is to operate beyond one or more of the limits specified above.

**NOTE:**

**In order to drive the pump from the side opposite the present shaft extension, simply remove the valve casing from the crankcase and rotate the pumps 180 degrees to the desired position. Be certain to rotate the seal case (item #20) as well, so that the weep holes are down at the six o'clock position. Exchange the oil fill and the oil drain plugs, also. Refer to the repair instructions as necessary for the proper assembly sequence.**

<b>P211 HORSEPOWER REQUIREMENTS</b>					
RPM	GPM	1000 PSI	1500 PSI	2000 PSI	2500 PSI*
500	0.60	0.4	0.6	0.8	1.0
1000	1.20	0.8	1.2	1.7	2.1
1750	2.10	1.4	2.2	2.9	3.6
3000	3.30	2.3	3.4	4.6	5.7
3200	3.52	2.4	3.6	4.9	6.1
3450	3.80	2.6	3.9	5.2	6.5

\*Intermittent duty only

**HORSEPOWER RATINGS:**

The rating shown are the power requirements for the pump. Gas engine power outputs must be approximately twice the pump power requirements shown above.

We recommend a 1.15 service factor be specified when selecting an electricmotor as the power source. To compute specific pump horse power requirements, use the following formula:

$$HP = (GPM \times PSI) / 1450$$

# Exploded View - P205/P206/P207/P208/P209/P210/P211

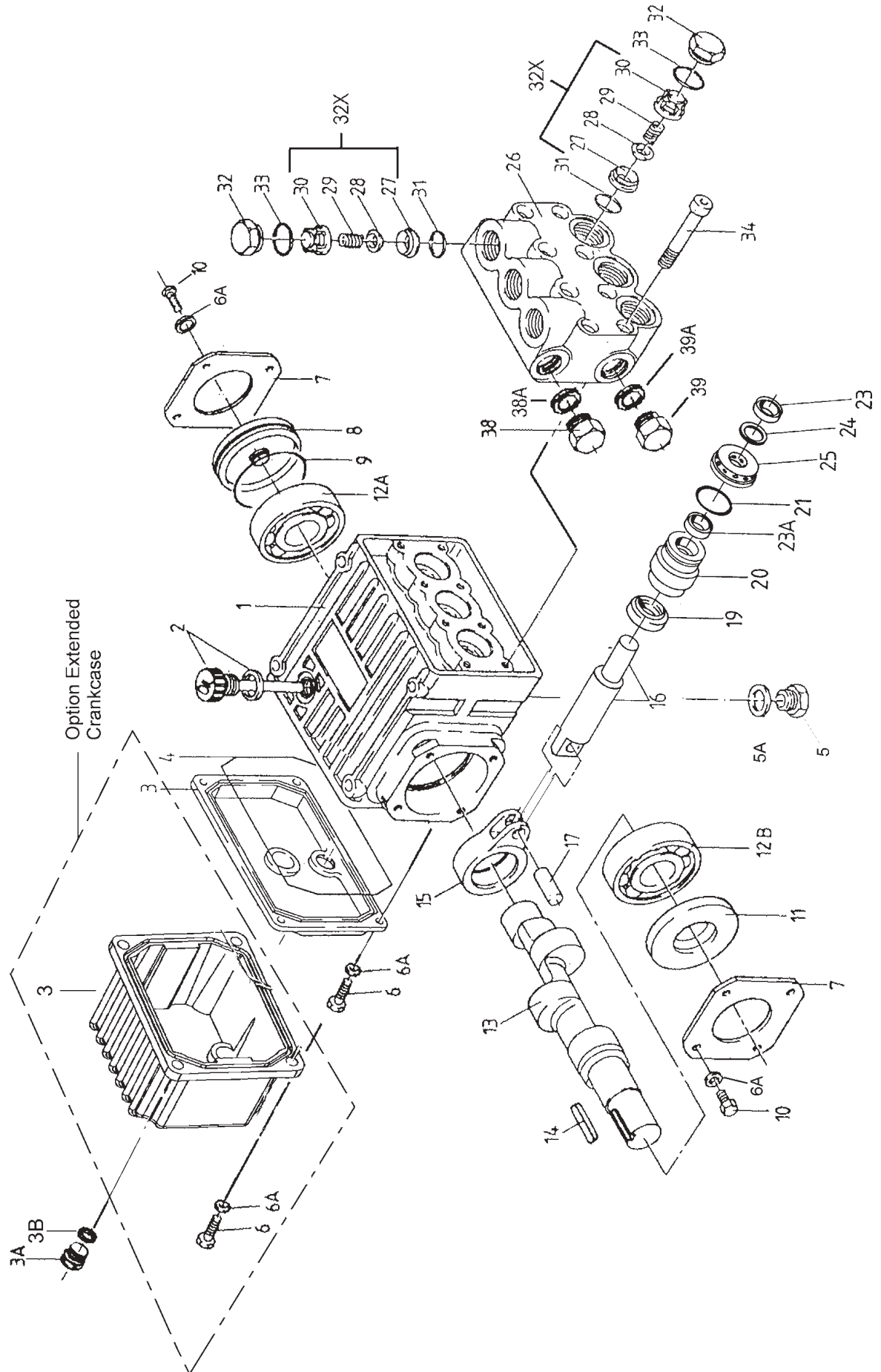

## P205/P206/P207/P208/P209/P210/P211 PARTS LIST

<u>ITEM</u>	<u>PART NO.</u>	<u>DESCRIPTION</u>	<u>QTY.</u>	<u>ITEM</u>	<u>PART NO.</u>	<u>DESCRIPTION</u>	<u>QTY.</u>
1	08300	Crankcase	1	14	06207	Woodruff Key	1
2	06773	Oil Dipstick with O-Ring	1	15	08333	Connecting Rod	3
3	08302	Crankcase Cover, Short	1	16	06641	Plunger, Complete, 12mm	3
3	08302-L	Crankcase Cover, Long	1	17	08442	Wrist Pin	3
3A	07190	Drain Plug	1	19	08356-0010	Oil Seal	3
3B	13262	Gasket for drain plug	1	20	06645	Seal Case	3
4	08005	O-Ring	1	21	08443	O-Ring	3
5	06273	Oil Drain Plug with Gasket	1	23	07391	V-Sleeve	3
5A	08192	Gasket	1	23A	08598	V-Sleeve, Weep	3
6	07188	Screw, Short Cover	4	24	07392	Support Ring	3
6A	01176-2	Spring Washer	12	25	06646	Weep Return Ring	3
7	08303	Bearing Cover I	2	26	06647	Valve Casing	1
8	08490	Sight Glass	1	27	07849	Valve Seat	6
9	08492	O-Ring for Sight Glass	1	28	07491	Valve Plate	6
10	07225	Screw with Lock Washer	8	29	07906	Valve Spring	6
11	01166	Radial Shaft Seal	1	30	07907	Valve Spring Retainer	6
12A	08020	Ball Bearing	1	31	07853	O-Ring	6
12B	01020	Ball Bearing	1	32	07928	Valve Plug	6
13	06694	Crankshaft (P205)	1	32X	07946A	Valve Assembly Complete	6
13	08465	Crankshaft (P206)	1	33	07913	O-Ring	6
13	06547	Crankshaft (P207)	1	34	08316	Hex Head Cap Screw	8
13	12258	Crankshaft (P208)	1	38	13338	Plug, 3/8" BSP	1
13	08440	Crankshaft (P209)	1	38A	07661	Seal	1
13	08466	Crankshaft (P210)	1	39	07109	Plug, 1/2" BSP	1
13	08467	Crankshaft (211)	1	39A	08486	Copper Seal Ring	1

## P205/P206/P207/P208/P209/P210/P211 REPAIR KITS

### Plunger Packing Kit

#### Part # 09152

<u>Item #</u>	<u>Part #</u>	<u>Description</u>	<u>Qty.</u>
21	08443	O-Ring	3
23	07391	V-Sleeve, weep	3
23A	08598	V-Sleeve	3
24	07392	Support Ring	3

### Oil Seal Kit

#### Part # 09144

<u>Item #</u>	<u>Part #</u>	<u>Description</u>	<u>Qty.</u>
19	08356-0010	Oil Seal	3

### Valve Assembly Kit

#### Part # 09116

<u>Item #</u>	<u>Part #</u>	<u>Description</u>	<u>Qty.</u>
32X	07946A	Valve Assembly Complete	6
31	07853	O-Ring	6
33	07913	O-Ring	6

### Optional Teflon Packing Kit

#### Part # 09527-0021

<u>Item #</u>	<u>Part #</u>	<u>Description</u>	<u>Qty.</u>
21	08443-0001	O-Ring	3
23/23A	07391-0020	V-Sleeve, Teflon	6
24	07392	Support Ring	3
31	07853-0001	O-Ring, Viton	6
33	07913-0001	O-Ring, Viton	6

## P205/P206/P207/P208/P210/P211 TORQUE SPECIFICATIONS

<u>Position</u>	<u>Item#</u>	<u>Description</u>	<u>Torque Amount</u>
32	07928	Valve Plug	59 (ft.-lbs.)
34	08316	Hex Head Cap Screw, Valve Casing	105 (in.-lbs.)

### Pump Mounting Selection Guide

<p><b>Bushings</b>  <b>01074</b> - 24 mm Tapered H Bushing</p>
<p><b>Pulley &amp; Sheaves</b>  <b>01061</b> - 7.75" Cast Iron 1 gr. - AB Section  <b>01062</b> - 7.75" Cast Iron - 2 gr. - AB Section</p>
<p><b>Rails</b>  <b>01160</b> - Plated Steel Channel Rails                      (L=5.75"x W=1.00"x h=2.50")  <b>01161</b> - Plated Steel Channel Rails                      (L=5.75"x W=1.00"x H=2.50")</p>

## REPAIR INSTRUCTIONS - P205/P206/P207/P208/P209/P210/P211 PUMPS

*NOTE: Always take time to lubricate all metal and nonmetal parts with a light film of oil before reassembly. This step will ensure proper fit, at the same time protecting the pump nonmetal parts (i.e., the elastomers) from cutting and scoring.*

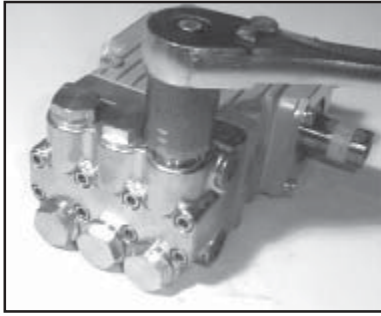

1. With a 22mm socket wrench, remove the (3) discharge valve plugs and (3) inlet valve plugs (32). Inspect the o-ring (33) for wear and replace if damaged.

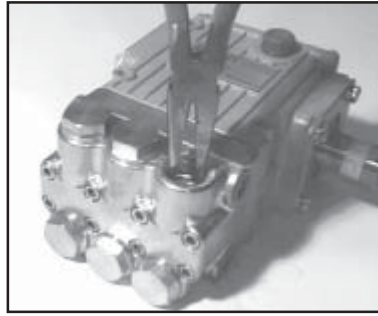

2. Using a needle nose pliers, remove the inlet and discharge valve assemblies (32X).



3. By inserting a small screw driver between the valve seat (27) and the valve spring retainer (30), the valve assembly can be separated.

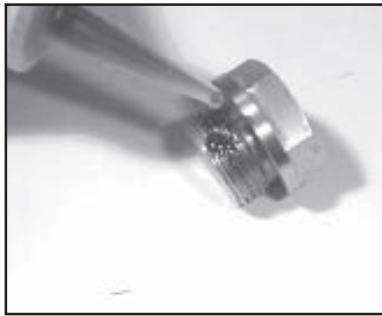

4. Remove the o-ring (31). Inspect all parts for wear and replace as necessary. For pumps manufactured prior to 5/97, tighten plugs (32) to 33 ft.-lbs. otherwise, apply one drop of Loctite 243 to the valve plugs (32) and tighten to 59 ft.-lbs.

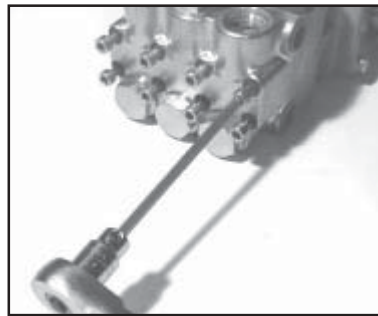

5. Next, use a 5mm allen wrench to remove the 8 socket head cap screws (34).

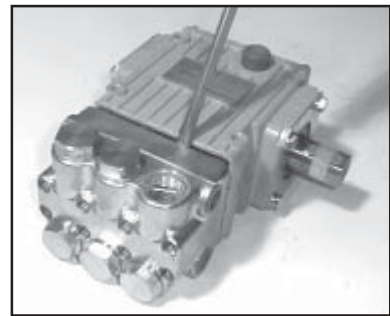

6. Carefully slide the valve casing (26) out over the plungers.



7. Remove the weep return ring (25), pressure ring (24), and v-sleeve (23) from the valve casing (26). Remove the weep v-sleeve (23A) from the seal case (20). Inspect all parts, including o-ring (21) for wear and replace as necessary.

8. Check surfaces of plunger (16). A damaged surface will cause accelerated wear on the seals. Deposits of any kind must be carefully removed from the plunger surface. A damaged plunger must be replaced!

9. If the crankcase oil seals (19) are to be replaced, they can be removed by first removing the crankshaft (13), connecting rod (15), and plunger assembly (16) from the gear end. Then the oil seals can be pushed out from the rear. Please contact Giant for details.

## REPAIR INSTRUCTIONS - P205/P206/P207/P208/P209/P210/P211 PUMPS

10. If the ceramic plunger pipe (16) is damaged, replace entire plunger assembly by removing crankshaft (13). Contact Giant for further details.

**NOTE: If there are deposits of any kind (i.e., lime deposits) in the valve casing, be certain that the weep holes in the weep return ring (25) and valve casing (26) have not been plugged.**

### Reassembly sequence of the P205/P206/P207/P208/P209/P210/P211 PUMPS

- 1) If oil seals (19) were removed, replace with seal lip towards crankcase. Lubricate seals before replacing. Contact Giant for assistance with the reassembly of the gear end.
- 2) Replace seal case (20) with o-rings (21) over plungers. Generously lubricate o-rings and oil seal before reassembly. Replace weep v-sleeve (23A) over plungers (16)..
- 3) Generously lubricate v-sleeve (23). Assemble v-sleeves (23) into valve casing (#26). Assemble weep return ring (25) and pressure ring (24) over plungers (16). Slide valve casing over plungers and seat firmly. Replace the eight socket head cap screws (34) and tighten to 105 inch-pounds in a crossing pattern.
- 4) Replace the six o-rings (31) and the six valve assemblies (32X). Now replace the six valve plug o-rings (33). Apply one drop of Loctite 243 to the valve plugs (32) and tighten to 59 ft.-lbs.

**For maintenance of the gear end of your pump contact Giant Industries or your local distributor. Phone: 419/531-4600**

**NOTE: Contact Giant Industries for Service School Information. Phone: (419)-531-4600**

<b>Preventative Maintenance Check-List &amp; Recommended Spare Parts List</b>						
<b>Check</b>	<b>Daily</b>	<b>Weekly</b>	<b>50hrs</b>	<b>Every 500 hrs</b>	<b>Every 1500 hrs</b>	<b>Every 3000 hrs</b>
Oil Level/Quality	X					
Oil Leaks	X					
Water Leaks	X					
Belts, Pulley		X				
Plumbing		X				
<b>Recommended Spare Parts</b>						
Oil Change (1 Quart) p/n 1153			X	X		
Seal Spare Parts (1 kit/pump) (See page 12 for kit list)					X	
Oil Seal Kit (1 kit/pump) (See page 12 for kit list)					X	
Valve Spare Parts (1 kit/pump) (See page 12 for kit list)						X



**P205/P206/P207/P208/P209/P210/P211 DIMENSIONS - Inches (mm)**

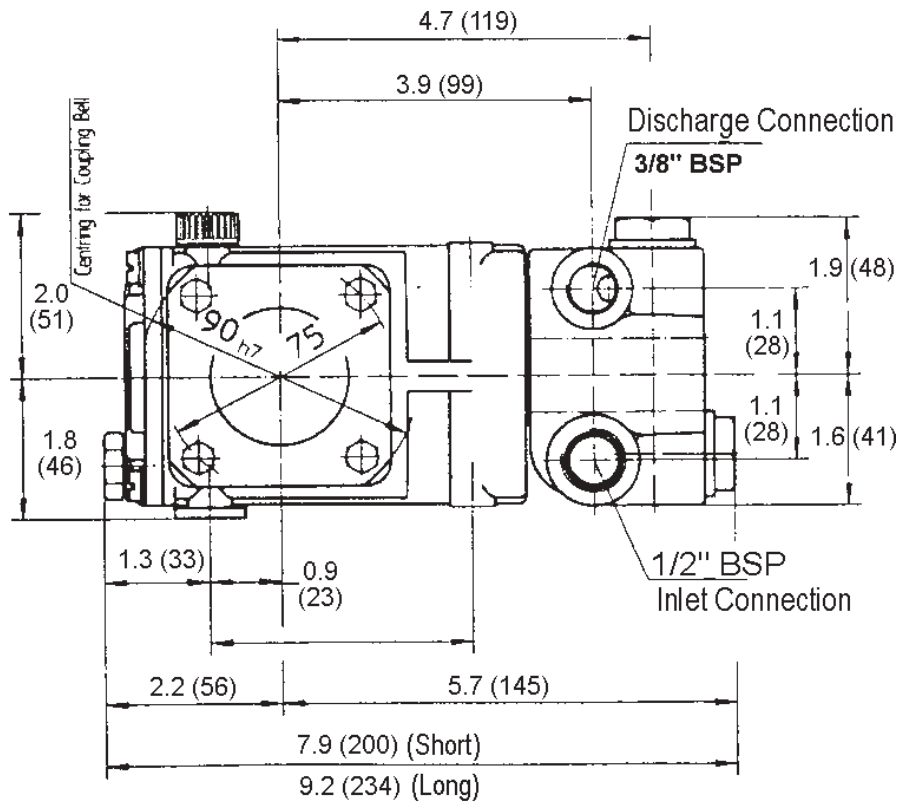
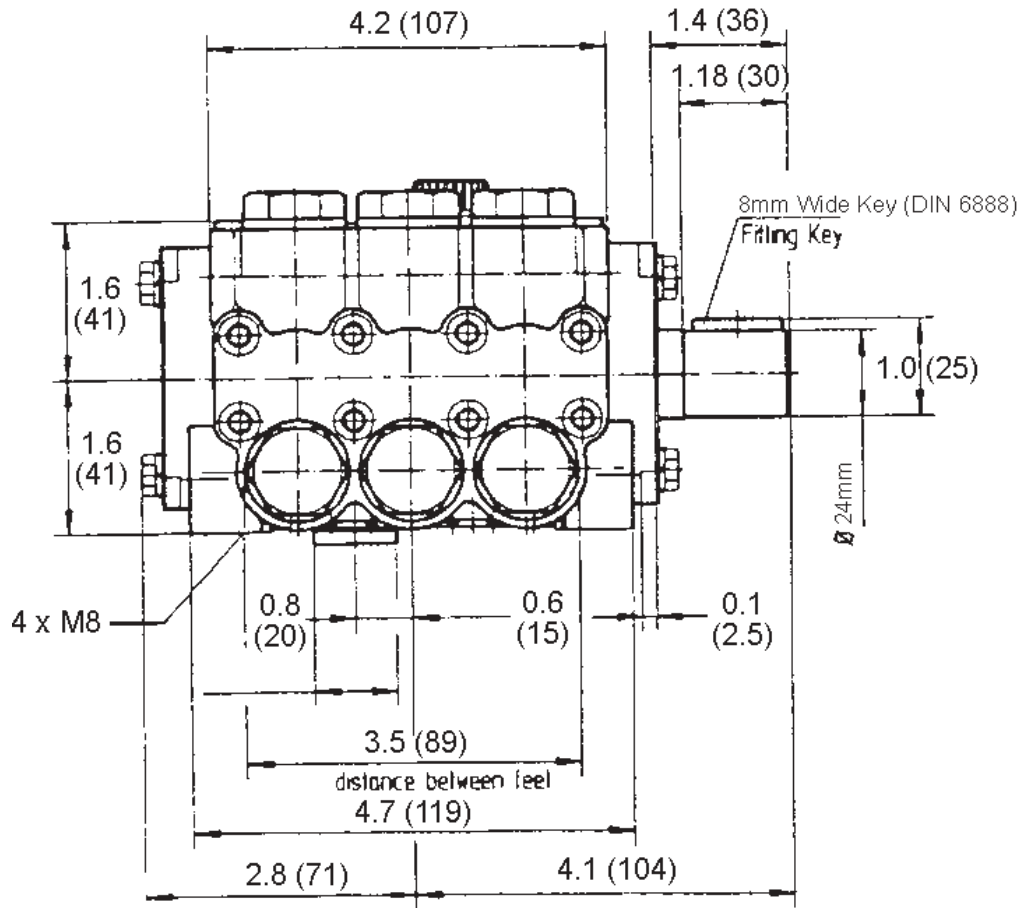

# GIANT INDUSTRIES LIMITED WARRANTY

Giant Industries, Inc. pumps and accessories are warranted by the manufacturer to be free from defects in workmanship and material as follows:

1. For portable pressure washers and self-serve car wash applications, the discharge manifolds will never fail, period. If they ever fail, we will replace them free of charge. Our other pump parts, used in portable pressure washers and in car wash applications, are warranted for five years from the date of shipment for all pumps used in NON-SALINE, clean water applications.
2. One (1) year from the date of shipment for all other Giant industrial and consumer pumps.
3. Six (6) months from the date of shipment for all rebuilt pumps.
4. Ninety (90) days from the date of shipment for all Giant accessories.

This warranty is limited to repair or replacement of pumps and accessories of which the manufacturer's evaluation shows were defective at the time of shipment by the manufacturer. The following items are NOT covered or will void the warranty:

1. Defects caused by negligence or fault of the buyer or third party.
2. Normal wear and tear to standard wear parts.
3. Use of repair parts other than those manufactured or authorized by Giant.
4. Improper use of the product as a component part.
5. Changes or modifications made by the customer or third party.
6. The operation of pumps and or accessories exceeding the specifications set forth in the Operations Manuals provided by Giant Industries, Inc.

Liability under this warranty is on all non-wear parts and limited to the replacement or repair of those products returned freight prepaid to Giant Industries which are deemed to be defective due to workmanship or failure of material. A Returned Goods Authorization (R.G.A.) number and completed warranty evaluation form is required prior to the return to Giant Industries of all products under warranty consideration. Call (419)-531-4600 or fax (419)-531-6836 to obtain an R.G.A. number.

Repair or replacement of defective products as provided is the sole and exclusive remedy provided hereunder and the MANUFACTURER SHALL NOT BE LIABLE FOR FURTHER LOSS, DAMAGES, OR EXPENSES, INCLUDING INCIDENTAL AND CONSEQUENTIAL DAMAGES DIRECTLY OR INDIRECTLY ARISING FROM THE SALE OR USE OF THIS PRODUCT.

THE LIMITED WARRANTY SET FORTH HEREIN IS IN LIEU OF ALL OTHER WARRANTIES OR REPRESENTATION, EXPRESS OR IMPLIED, INCLUDING WITHOUT LIMITATION ANY WARRANTIES OR MERCHANTABILITY OR FITNESS FOR A PARTICULAR PURPOSE AND ALL SUCH WARRANTIES ARE HEREBY DISCLAIMED AND EXCLUDED BY THE MANUFACTURER.



**GIANT INDUSTRIES, INC.**, 900 N. Westwood Ave., P.O. Box 3187, Toledo, Ohio 43607  
PHONE (419) 531-4600, FAX (419) 531-6836, [www.giantpumps.com](http://www.giantpumps.com)  
© Copyright 2009 Giant Industries, Inc.