

BGP-DS

2 HP @ 3450 RPM



IMPORTANT! - Read all instructions in this manual before operating or servicing a pump.

Before installation, read the following instructions carefully. Failure to follow instruction and safety information could cause serious bodily injury, death and/or property damage. Each Barmesa product is carefully inspected to insure proper performance. Closely following these instructions will eliminate potential operating problems, assuring years of trouble-free service.

⚠ DANGER "Danger" indicates an imminently hazardous situation which, if not avoided, WILL result in death or serious injury.

⚠ WARNING "Warning" indicates an imminently hazardous situation which, if not avoided, MAY result in death or serious injury.

⚠ CAUTION "Caution" indicates a potentially hazardous situation which, if not avoided, MAY result in minor or moderate injury.

IMPORTANT! - Barmesa Pumps is not responsible for losses, injury or death resulting from failure to observe these safety precautions, misuse, abuse or misapplication of pumps or equipment.

 **ALL RETURNED PRODUCTS MUST BE CLEANED, SANITIZED, OR DECONTAMINATED PRIOR TO SHIPMENT, TO INSURE EMPLOYEES WILL NOT BE EXPOSED TO HEALTH HAZARDS IN HANDLING SAID MATERIAL. ALL APPLICABLE LAWS AND REGULATIONS SHALL APPLY.**

⚠ WARNING Bronze/brass fitted pumps may contain levels higher than considered safe for potable water systems. Government agencies have determined that leaded copper alloys should not be used in potable water applications.

⚠ WARNING Installation, wiring, and junction connections must be in accordance with the National Electric Code and all applicable state and local codes. Requirements may vary depending on usage and location.

⚠ WARNING Installation and servicing is to be conducted by qualified personnel only.



Keep clear of suction and discharge openings. Do not insert fingers in pump with power connected; the rotating cutter and/or impeller can cause serious injury.



Always wear eye protection when working on pumps. Do not wear loose clothing that may become entangled in moving parts.



⚠ DANGER Pumps build up heat and pressure during operation. Allow time for pumps to cool before handling or servicing the pump or any accessory items associated with or near the pump.



⚠ DANGER This pump is not intended for use in swimming pools or water installations where there is human contact with pumped fluid.



⚠ DANGER Risk of electric shock. To reduce risk of electric shock, always disconnect pump from power source before handling. **Lock out power and tag.**

⚠ WARNING Do not use these pumps in water over 104° F. Do not exceed manufacturers recommended maximum performance, as this could cause the motor to overheat.



⚠ DANGER Do not lift, carry or hang pump by the electrical cables. Damage to the electrical cables can cause shock, burns or death. **Never** handle connected power cords with wet hands. Use appropriate lifting device.

⚠ WARNING Sump and sewage pumps often handle materials which could cause illness or disease. Wear adequate protective clothing when working on a used pump or piping. Never enter a basin after it has been used.

⚠ DANGER



Failure to permanently ground the pump, motor and controls before connecting to power can cause shock, burns or death.

⚠ DANGER



These pumps are not to be installed in locations classified as hazardous in accordance with the National Electric Code, ANSI/NFPA 70.

⚠ WARNING

Do not introduce into any sewer, either directly, or through a kitchen waste disposal unit or toilet: *seafood shells, aquarium gravel, cat litter, plastic objects (toys, utensils, etc.), sanitary napkins or tampons, diapers, rags, disposable wipes or cloth, medications, flammable material, oil or grease, strong chemicals, gasoline.*

IMPORTANT! - Prior to installation, record Model Number, Serial, Amps, Voltage, Phase and HP from pump name plate for the future reference. Also record the Voltage and Current Readings at Startup:

1 Phase Models	
Amps:	Volts:
3 Phase Models	
Amps L1-2:	Volts L1-2:
Amps L2-3:	Volts L2-3:
Amps L3-1:	Volts L3-1:

Model Number: _____

Serial: _____

PHASE: _____ HP: _____

- DISCHARGE:** 1¼" NPT, vertical.
- LIQUID TEMPERATURE:** **Continuous:** 120° F (48° C) max.
Intermittent: 140° F (60° C) max.
- VOLUTE:** Cast iron ASTM A-48 class 30.
- MOTOR HOUSING:** Cast iron ASTM A-48 class 30.
- SEAL PLATE:** Cast iron ASTM A-48 class 30.
- IMPELLER:** 12 vanes, vortex, with vanes on back side, dynamically balanced. Cast iron ASTM A-48 class 30.
Radial cutter: hardened 440C, stainless steel, hardness Rockwell C-55.
Shredding ring: hardened 440C, stainless steel, hardness Rockwell C-55.
- SHAFT:** 420 series stainless steel.
- O-RINGS:** Buna-N.
- PAINT:** Air dry enamel, water based.
- SEAL:** Double mechanical, oil lubricated. Ceramic stationary part, carbon ring seal and exclusion in the rotating part, and silicon-silicon in the secondary (pump) seal. Buna-N elastomer and stainless steel spring.
- HARDWARE:** Stainless steel.
- CORD ENTRY:** 30 ft of neoprene cord, sealed against moisture.
- BEARINGS:** Ball, single row, oil lubricated.
- MOTOR:** **Single phase:** permanent split capacitor, oil filled, with overload protection in motor. Class F insulation. Model BGP202DS requires capacitors and relay to be installed in control panel. Model BGPC202DS offers internal capacitor design.
Three phase: oil filled, with overload protection in motor. Class F insulation.
- MOISTURE SENSOR:** Normally open (N/O) included.
- TEMPERATURE SENSOR:** Normally closed (N/C). It requires a relay in the control panel.
- OPTIONAL EQUIPMENT:** Additional cord, slide rail coupling (SRC-1¼").

MODEL	HP	VOLTS	PHASE	RPM (nominal)	MAX AMPS	LOCKED ROTOR AMPS	CORD SIZE	CORD TYPE	INTERNAL CAPACITOR	MOISTURE SENSOR	WEIGHT (pounds)
BGP202DS	2	230	1	3450	14.5	23	12/3	SOOW	No	Yes	130
BGP203DS	2	230	3	3450	8.8	22.5	12/4	SOOW	n/a	Yes	130
BGP204DS	2	460	3	3450	4.4	11.3	12/4	SOOW	n/a	Yes	130
BGPC202DS	2	230	1	3450	14.5	23	12/3	SOOW	Yes	No	130
BGPC202DSA*	2	230	1	3450	14.5	23	12/3	SOOW	Yes	No	130

* Includes the level control with the pump.

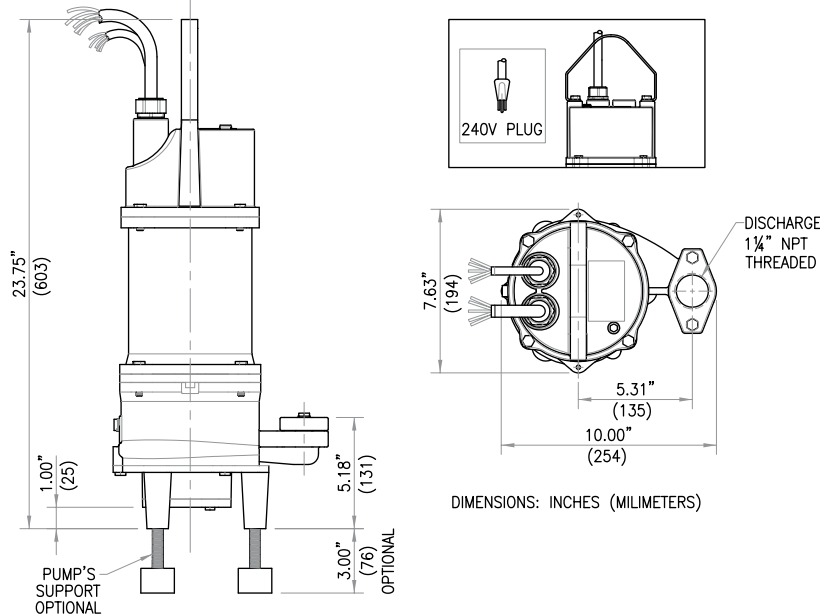

► Receiving inspection

Upon receiving the pump, it should be inspected for damage or shortages. If damage has occurred, file a claim immediately with the company that delivered the pump. If the manual is removed from the packaging, do not lose or misplace.

► Storage

Any product that is stored for a period longer than six (6) months from the date of purchase should be bench tested prior to installation. A bench test consists of, checking the impeller to assure it is free turning. **DO NOT TURN IMPELLER WITH FINGERS AS EDGES ARE SHARP**, use allen wrench in the impeller screw to turn the impeller. Run test to assure the motor (and switch if provided) operate properly.

► Controls

BGP series grinders require a separate approved pump control device or panel for automatic operation. Be sure the electrical specification of the control selected properly match the electrical specifications of the pump.

► Submergence

The pump should always be operated in the submerged condition. The minimum sump liquid level should never be less than above the pump's volute (See Figure 1).



IMPORTANT! - A clearance under the pump for entrance of sewage solids must be a minimum of 3" to a maximum of 4.5".

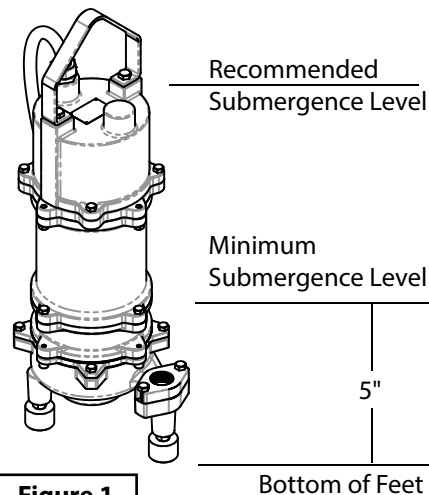

Figure 1

► Location

The grinder pump is designed to fit in basin or wetwell by using a slide rail coupling (SRC-1¼").

► Installation

There are several methods of installing grinder pumps. See contract plans and/or specification: A slide rail in a package system or concrete wet well is the most common, which allows the pump(s) to be installed or removed without requiring personnel to enter the wet well.

These pumps are recommended for use in a sump, basin or lift station. The sump, basin or lift station shall be sealed and vented in accordance with local plumbing codes. **This pump is designed to pump grinder or wastewater, non-explosive and non-corrosive liquids and shall NOT be installed in locations classified as hazardous in accordance with the National Electrical Code (NEC) ANSI/NFPA 70 or Canadian Electric Code (CEC).**

The pump should never be installed in a trench, ditch, or hole with a dirt bottom. The legs will sink into the dirt and the suction will become plugged.

The installation should be at a sufficient depth to ensure that all plumbing is below the frost line. If this is not feasible, remove the check valve and size the basin to accommodate the additional backflow volume.

► Discharge Piping

Discharge piping should be as short as possible and sized no smaller than the pump discharge. **Do not reduce the discharge pipe size below that which is provided on the pump.** Both a check valve and a shut-off valve are recommended for each pump. The check valve is used to prevent backflow into the sump. The shut-off valve is used to manually stop system low during pump servicing.

► Liquid Level Controls

The level control(s) should be mounted on the discharge piping, a cable rack or float pole. The level control should have adequate clearance so it cannot hang up in it's swing and that the pump is completely submerged when the level control is in the "Off" mode. By adjusting the cord tether the control level can be changed. One cycle of operation should be observed, so that any potential problems can be corrected.

It is recommended that the level control float should be set to insure that the liquid in the sump never drops below the top of the motor housing or a minimum level of 10 inches above the basin floor.

► Electrical Connections

Power cable:

The power cable mounted to the pump must not be modified in any way except for shortening to a specific application.

Any splice between the pump and the control panel must be made in accordance with the electric codes. It is recommended that a junction box, if used, be mounted outside the sump or be of at a minimum Nema 4 construction if located within the wet well. **DO NOT USE THE POWER CABLE TO LIFT PUMP.**

Always rely upon a Certified Electrician for installation.

Overload Protection:

Single Phase - The stator in-winding overload protector used is referred to as an inherent overheating protector and operates on the combined effect of temperature and current. This means that the overload protector will trip out and shut the pump off if the windings become too hot, or the load current passing through them becomes too high.

IMPORTANT! - The overload will then automatically reset and start the pump up after the motor cools to a safe temperature. In the event of an overload, the source of this condition should be determined and corrected immediately.

⚠ WARNING DO NOT ALLOW THE PUMP TO CYCLE OR RUN IF AN OVERLOAD CONDITION OCCURS.

If current through the temperature sensor exceeds the values listed, an intermediate control circuit relay must be used to reduce the current or the sensor will not work properly.

TEMPERATURE SENSOR ELECTRICAL RATINGS		
Volts	Continuous Amperes	Inrush Amperes
110-120	3.00	30.0
220-240	1.50	15.0
440-480	0.75	7.5
600	0.60	6.0

Moisture Sensors - A normally open (N/O) sensor rated of 1 watt @330K ohms, 500 volt, is installed in the pump seal chamber which will detect any moisture present. It is recommended that this detector be wired in series to an alarm device or motor starter coil to alert the operator that a moisture detect has occurred. In the event of a moisture detect, check the individual moisture sensor probe leads for continuity, (∞ resistance = no moisture) and the junction box/control box for moisture content.

These situations may induce a false signal in the moisture detecting circuit. If none of the above test prove conclusive, the pump(s) should be pulled and the source of the failure repaired. **IF A MOISTURE DETECT HAS OCCURRED MAINTENANCE SHOULD BE PERFORMED AS SOON AS POSSIBLE!**

Wire Size:

If longer power cable is required consult a qualified electrician for proper wire size.

▶ **Pre-Operation**

- 1. Check Voltage and Phase** - Compare the voltage and phase information stamped on the pump name plate.
- 2. Check Pump Rotation** - Improper motor rotation can result in poor pump performance and can damage the motor and/or pump. Check rotation on three phase units by momentarily applying power and observe the "kickback".

Kickback should always be in a counter-clockwise direction as viewed from motor end or opposite to impeller rotation. Impeller rotation is counter-clockwise as viewed from bottom of pump.

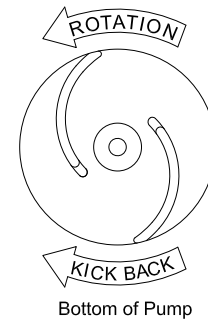

3. Name Plate - Record the information from the pump name plate to drawing in front of manual for future reference.

4. Insulation Test - An insulation (megger) test should be performed on the motor. Before the pump is put into service. The resistance values (ohms) as well as the voltage (volts) and current (amps) should be recorded.

5. Pump-Down Test - Be sure pump has been properly wired, lowered into the basin, sump or lift station, check the system by filling with liquid and allowing the pump to operate through its pumping cycle. The time needed to empty the system, or pump-down time along with the volume of water, should be recorded.

▶ **Maintenance**

No lubrication or maintenance is required. Perform the following checks when pump is removed from operation or when pump performance deteriorates:

- Inspect motor chamber for oil level and contamination.
- Inspect impeller and body for excessive build-up or clogging.
- Inspect motor, bearings and shaft seal for wear or leakage.



IMPORTANT! - This pump is not to be disassembled in the field except at certified service stations or at the factory. Warranty is void if pump is taken apart for any reason other than to replace grinder impeller and grinder ring, which is covered in these instructions.

► Disassembly

This is the only disassembly operation permitted in the field. All other repairs must be performed at an authorized service center or the factory.

Standard tools required:

- Standard socket wrench set.
- Standard set of open end wrenches.
- Hammer.
- Vise grip pliers.
- Allen head socket set.
- Screwdrivers.
- Wire brush.



WARNING Disconnect all power and control wires to motor at the control panel before starting the disassembly operations. Do not rely upon opening the circuit breaker only.



IMPORTANT! - The pump should be sanitized with bleach and thoroughly cleaned of trash and deposits before starting disassembly operations. Wear protective gloves and clothing. Always use a rag on the impeller when turning to prevent cutting hands on the sharp edges of the shredding ring.

Shredding Ring and Grinder Impeller

1. Hold the grinder impeller by prying against the impeller cutting bar and remove the allen head cap screw from the end of the shaft.

2. Use a large screwdriver in the slot end of the shaft and tap (counterclockwise) on one of the large cutter vanes with a hammer. Tap in a counterclockwise direction (thread is right hand).

3. If the impeller removes easily, clean and replace if worn.

4. Make sure the pump impeller has not loosened when the grinder impeller was removed. This can be checked on reassembly of grinder impeller and shredding ring. The tips of the impeller cutter vanes should extend 1/8" below the bottom of the shredding ring. If the distance is greater, the pump impeller has loosened. If the distance is less, the shredding ring is not properly seated.

5. After the volute case has been removed, insert screwdriver in slot end of shaft and tap hammer against the outer vane of the ductile iron pump impeller (clockwise) to ensure it is threaded tight against shoulder on shaft.

6. Use large screwdriver to tap stainless steel cutter ring from cast iron volute.

7. Clean all threads with a wire brush and file smooth any nicked threads. Use *NEVER-SEEZE* or other graphite compound on threads before replacing grinder impeller.

8. Make sure allen head cap screw in bottom of pumpshaft is tight. Make sure the impeller turns freely by hand after reassembly. Some drag will be present due to the shaft seals. There should not be any binding or tight spots when turning the grinder impeller.

► Motor Power Cords

Pump models with seal leak detector use a 5 conductor, #12 gauge cord. The three power conductors are BLACK, WHITE and RED. The BLUE or ORANGE conductor connects to the seal leak probe and GREEN conductor connects to the ground screw inside the cord cap. For single phase, BLACK is "Common", WHITE is "Run", and RED is "Start".

Cord Seal - The lines from the motor chamber are sealed with a rubber sealing grommet that prevents oil from leaking into the cord cap compartment. If it is necessary to replace the power cord, the sealing grommet must not be loosened. This wire seal is removed only for complete motor repair that must be done at an authorized service center.



IMPORTANT! - Ground wires must be connected in the control box to a grounding bar, which is connected to a good suitable ground. MOTOR IS NOT SAFE UNLESS PROPERLY GROUNDED.

Figure 2

▶ 208/230 volts, single phase

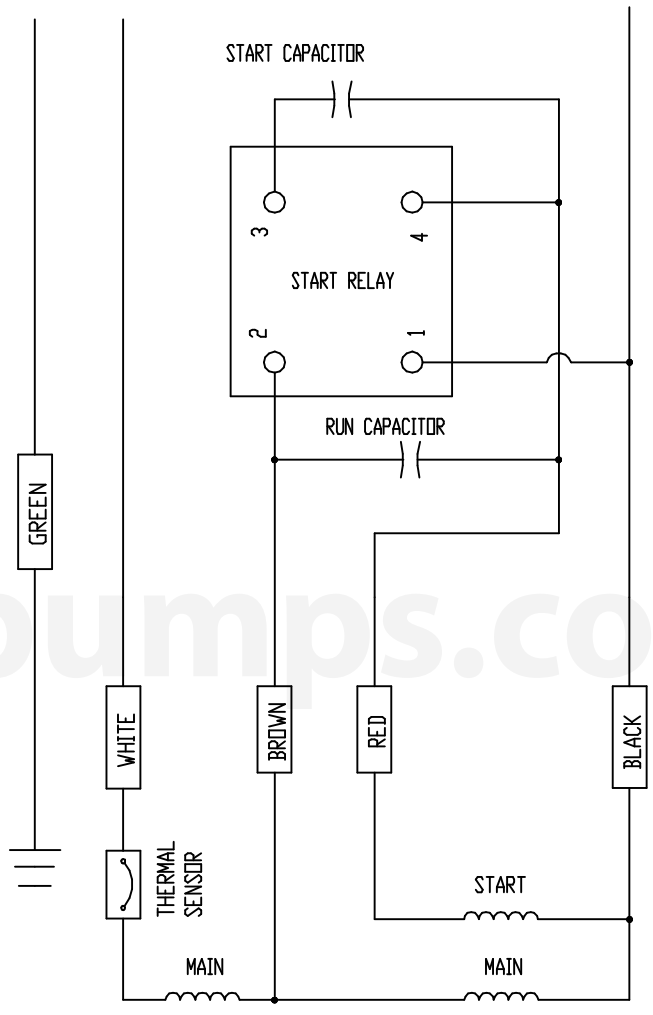
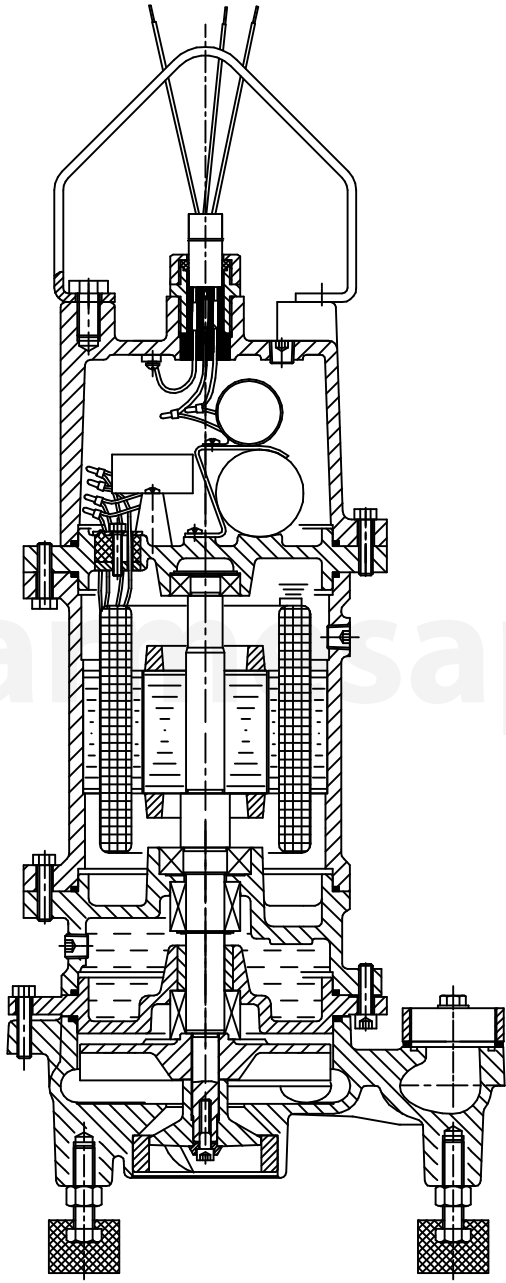

OHM		
WHITE (1)	BLACK (2)	1.2

Figure 3

▶ 208/230 volts, single phase

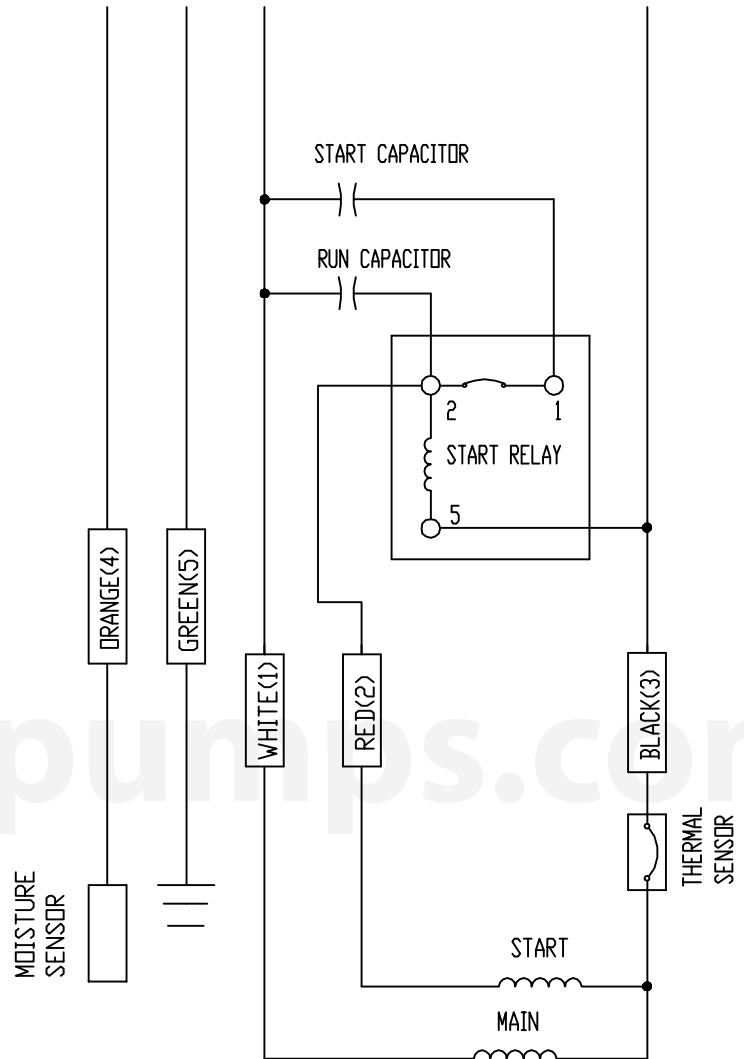
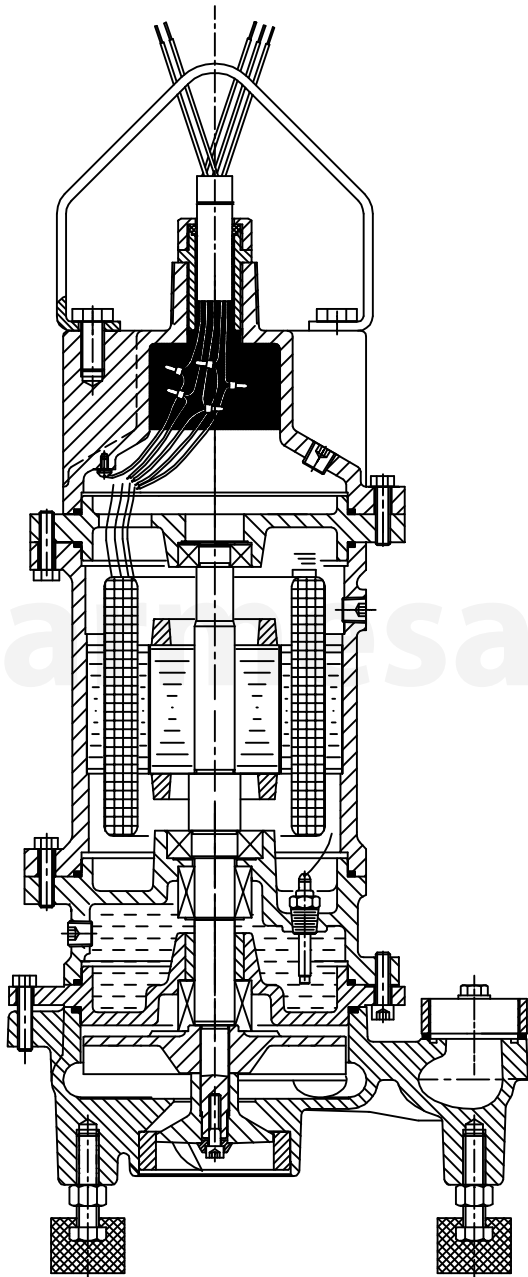

OHM		
WHITE (1)	BLACK (3)	1.1
WHITE (1)	RED (2)	3.8
BLACK (3)	RED (2)	2.9

▶ 230/460 volts, three phase

Figure 4

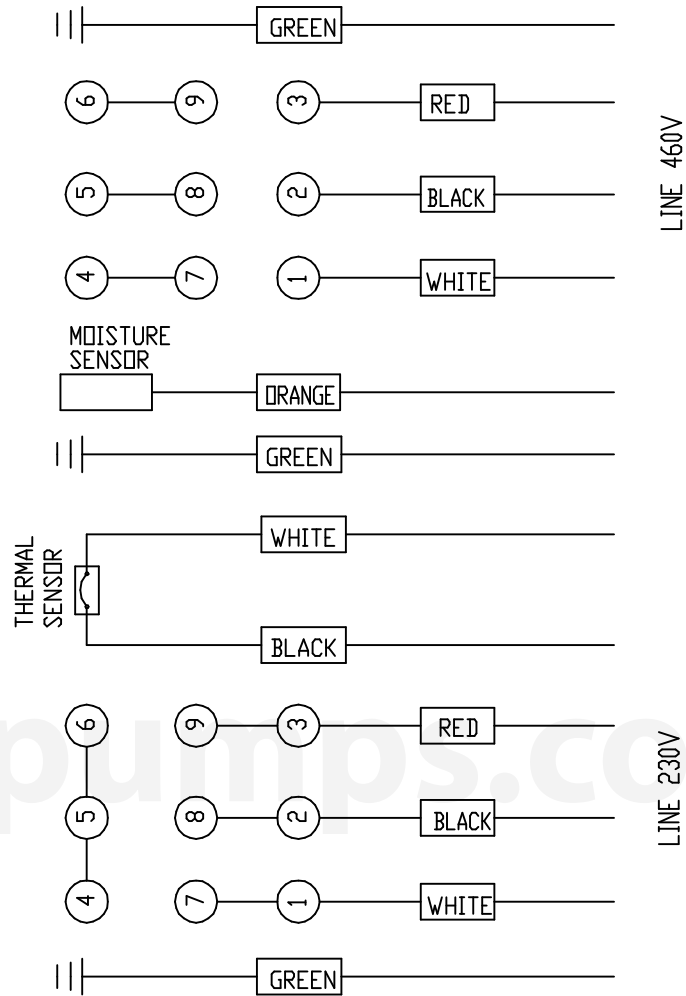
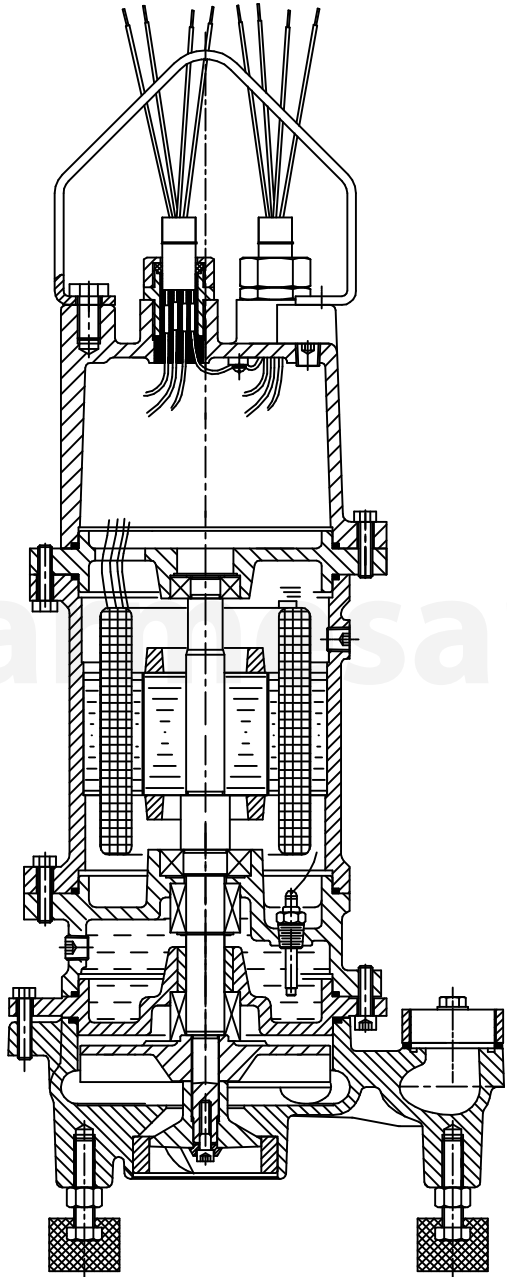

230 VOLT		OHM
WHITE	BLACK	2.0
WHITE	RED	2.0
BLACK	RED	2.0
460 VOLT		
WHITE	BLACK	7.6
WHITE	RED	7.6
BLACK	RED	7.6

Figure 5

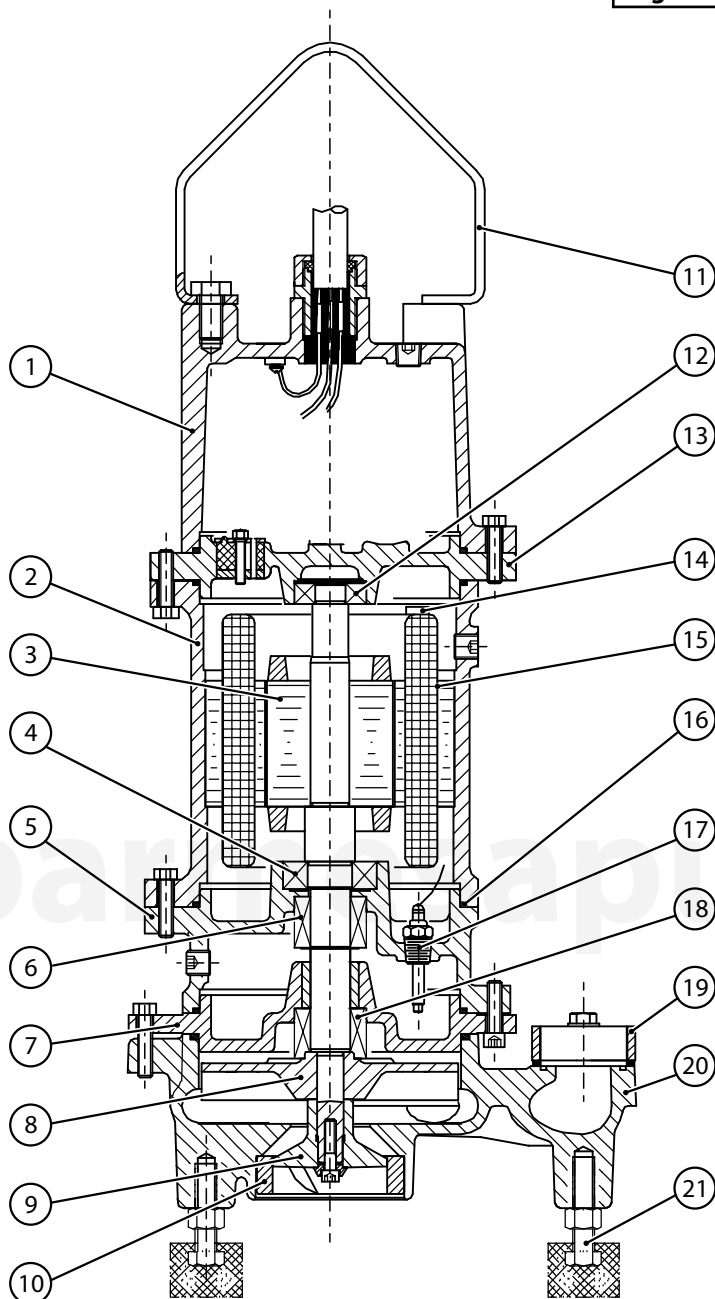

PART LIST			
ITEM	QTY.	DESCRIPTION	MATERIAL
1	1	PUMP COVER	CAST IRON
2	1	MOTOR HOUSING	CAST IRON
3	1	ROTOR	-
4	1	BEARING 6205	-
5	1	LOWER BEARING HOUSING	CAST IRON
6	1	MECHANICAL SEAL	SiC - SiC
7	1	SEAL PLATE	CAST IRON
8	1	IMPELLER	CAST IRON
9	1	RADIAL CUTTER	STAINLESS
10	1	SHREDDING RING	STAINLESS
11	1	HANDLE	STAINLESS
12	1	BEARING 6205	-
13	1	UPPER BEARING HOUSING	CAST IRON
14	1	THERMAL PROTECTOR	-
15	1	STATOR	-
16	4	O-RING	BUNA-N
17	1	MOISTURE SENSOR	-
18	1	MECHANICAL SEAL	SiC - SiC
19	1	FLANGE	CAST IRON
20	1	VOLUTE	CAST IRON
21	3	LEG EXTENSION	

For Repair Part Please supply: Model Number and Serial as shown on Name Plate, and Part Description and Part Number as shown on Parts List.



Risk of electric shock. Always disconnect the pump from the power source before handling inspections or repairs.

Symptom	Possible Cause(s)	Corrective Action
Pump will not run	<ol style="list-style-type: none"> 1. Poor electrical connection, blown fuse, tripped breaker or other interruption of power; improper power supply 2. Motor or switch inoperative (go to manual operation) <ol style="list-style-type: none"> 2a. Float movement restricted 2b. Switch will not activate pump or is defective 2c. Defective motor 3. Insufficient liquid level 	<ol style="list-style-type: none"> 1. Check all electrical connections for security. Have electrician measure current in motor leads, if current is within $\pm 20\%$ of locked rotor Amps, impeller is probably locked. If current is 0, overload may be tripped. Remove power, allow pump to cool, then re-check current. 2a. Reposition pump or clean basin as required to provide adequate clearance for float 2b. Disconnect level control. Set ohmmeter for a low range, such as 100 ohms full scale and connect to level control leads. Actuate level control manually and check to see that ohmmeter shows zero ohms for closed switch and full scale for open switch. (Float Switch) 2c. Check winding insulation (Megger Test) and winding resistance. If check is outside of range, dry and re-check. If still defective, replace per service instructions. 3. Make sure liquid level is above the pump 4. Re-check all sizing calculations to determine proper pump size. 5. Check discharge line for restrictions, including ice if line passes through or into cold areas. 6. Remove and examine check valve for proper installation and freedom of operation 7. Open valve 8. Check impeller for freedom of operation, security and condition. Clean impeller cavity and inlet of any obstruction 9. Loosen union slightly to allow trapped air to escape. Verify that turn-off level of switch is set so that the suction is always flooded. Clean vent hole 10. Check rotation. If power supply is three phase, reverse any two of three power supply leads to ensure proper impeller rotation 11. Repair fixtures as required to eliminate leakage 12. Check pump temperature limits and fluid temperature 13. Replace portion of discharge pipe with flexible connector or tighten existing piping. 14. Turn to automatic position 15. Check for leaks around basin inlet and outlets
Pump will not turn off	<ol style="list-style-type: none"> 2a. Float movement restricted 2b. Switch will not activate pump or is defective 4. Excessive inflow or pump not properly sized for application 9. Pump may be air locked causing pump not to flow 14. H-O-A switch on panel is in "HAND" position 	
Pump hums but doesn't run	<ol style="list-style-type: none"> 1. Incorrect low voltage 8. Impeller jammed or loose on shaft, or inlet plugged 	
Pump delivers insufficient capacity	<ol style="list-style-type: none"> 1. Incorrect low voltage 4. Excessive inflow or pump not properly sized for application 5. Discharge restricted 6. Check valve partially closed or installed backwards 7. Shut-off valve closed 8. Impeller jammed or loose on shaft, or inlet plugged 9. Pump may be air locked causing pump not to flow 10. Piping fixtures leaking or discharge before the nozzle 	
Pump cycles too frequently or runs periodically when fixtures are not in use	<ol style="list-style-type: none"> 6. Check valve partially closed or installed backwards 11. Fixtures are leaking 15. Ground water entering basin 	
Pump shuts off and turns on independent of switch, (trips thermal overload protector). CAUTION! Pump may start unexpectedly. Disconnect power supply.	<ol style="list-style-type: none"> 1. Incorrect low voltage 4. Excessive inflow or pump not properly sized for application 8. Impeller jammed or loose on shaft, or inlet plugged 12. Excessive water temperature (internal protection only) 	
Pump operates noisily or vibrates excessively	<ol style="list-style-type: none"> 2c. Worn bearings, motor shaft bent 5. Debris in impeller cavity or broken impeller 10. Pump running backwards 13. Piping attachments to building structure too loose or rigid 	

NOTE: Barmesa Pumps assumes no responsibility for damage or injury due to disassembly in the field. Disassembly of the pumps or supplied accessories other than at Barmesa Pumps or its authorized service centers, automatically voids warranty.

BARMESA PUMPS FACTORY WARRANTY

Barmesa Pumps warrants that products of our manufacture will be free of defects in material and workmanship under normal use and service for 18 months from date of manufacture or 12 months from installation date whichever occurs first. This warranty gives you specific legal rights, which vary from state to state.

This warranty is a limited warranty, and no warranty related claims of any nature whatsoever shall be made against Barmesa Pumps, until the ultimate consumer or his/her successor notifies us in writing of the defect and delivers the product and/or defective part(s) freight prepaid to our factory or nearest authorized service station as instructed by Barmesa Pumps. THERE SHALL BE NO FURTHER LIABILITY, WHETHER BASED ON WARRANTY, NEGLIGENCE OR OTHERWISE. PRODUCT SHALL BE EITHER REPLACED OR REPAIRED AT THE ELECTION OF BARMESA PUMPS. Guarantees relating to performance specifications provided in addition to the foregoing material and workmanship warranties on a product manufactured by Barmesa Pumps, if any, are subject to possible factory testing. Any additional guarantees, in the nature of certified performance specifications or time frame must be in writing and such writing must be signed by our authorized factory manager at time of order placement and/or at time of quotation. Due to inaccuracies in field testing and should a conflict arises between the results of field testing conducted by or for the user, Barmesa Pumps reserves the right to have the product returned to our factory for additional testing.

This warranty shall not apply when damage is caused by (1) improper installation, (2) improper voltage, (3) lightning, (4) excessive sand or other abrasive material, (5) corrosion build-up due to excessive chemical content or (6) uncontrollable acts of god. Any modification of the original equipment will also void the warranty. We will not be responsible for loss, damage or labor cost due to interruption of service caused by defective pumps, parts or systems. Barmesa Pumps will not accept charges incurred by others without our prior written approval.

This warranty is void if our inspection reveals the product was used in a manner inconsistent with normal industry practice and/or our specific recommendations. The purchaser is responsible for communication of all necessary information regarding the application and use of the product. UNDER NO CIRCUMSTANCES WILL WE BE RESPONSIBLE FOR ANY OTHER DIRECT OR CONSEQUENTIAL DAMAGES, INCLUDING BUT NOT LIMITED TO TRAVEL EXPENSES, CONTRACTOR FEES, UNAUTHORIZED REPAIR SHOP EXPENSES, LOST PROFITS, LOST INCOME, LABOR CHARGES, DELAYS IN PRODUCTION, IDLE PRODUCTION, WHICH DAMAGES ARE CAUSED BY ANY DEFECTS IN MATERIAL AND/OR WORKMANSHIP AND/OR DAMAGE OR DELAYS IN SHIPMENT. THIS WARRANTY IS EXPRESSLY IN LIEU OF ANY OTHER EXPRESS OR IMPLIED WARRANTY. No rights extended under this warranty shall be assigned to any other person, whether by operation of law or otherwise, without our prior written approval.

IMPORTANT!

If you have a claim under the provision of the warranty, contact Barmesa Pumps or your authorized Barmesa Pumps Distributor:
warranty@barmesapumps.com
www.barmesapumps.com

