

K Series

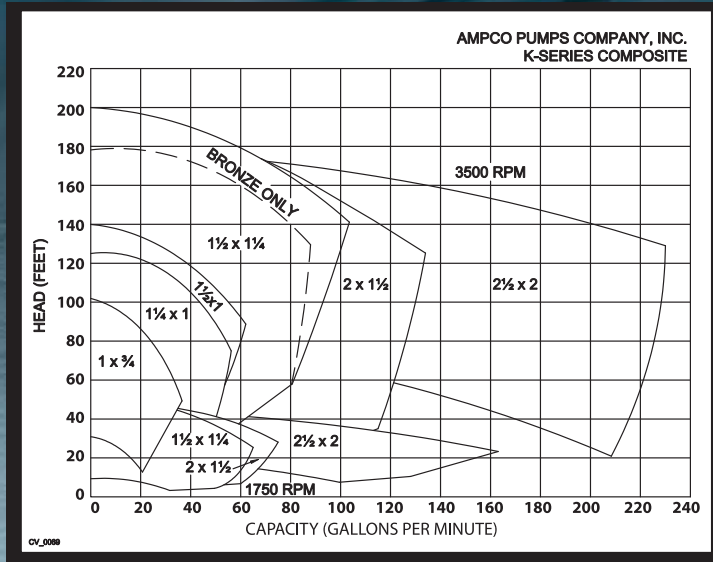

R Series

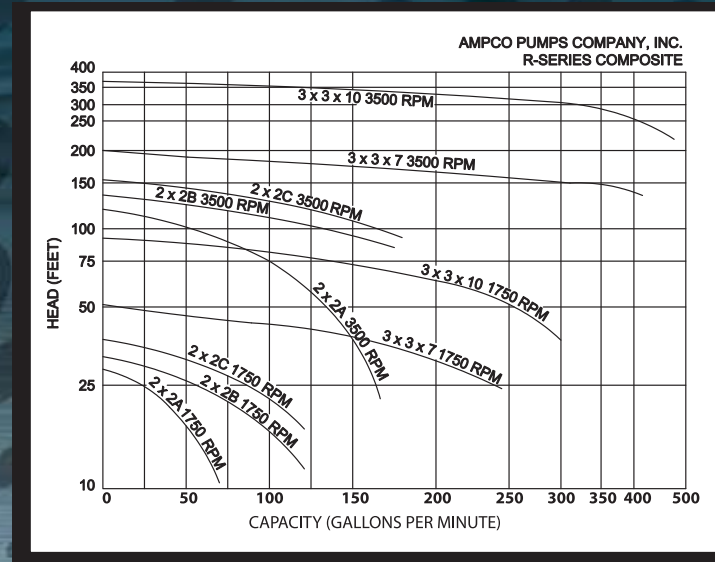

Z Series

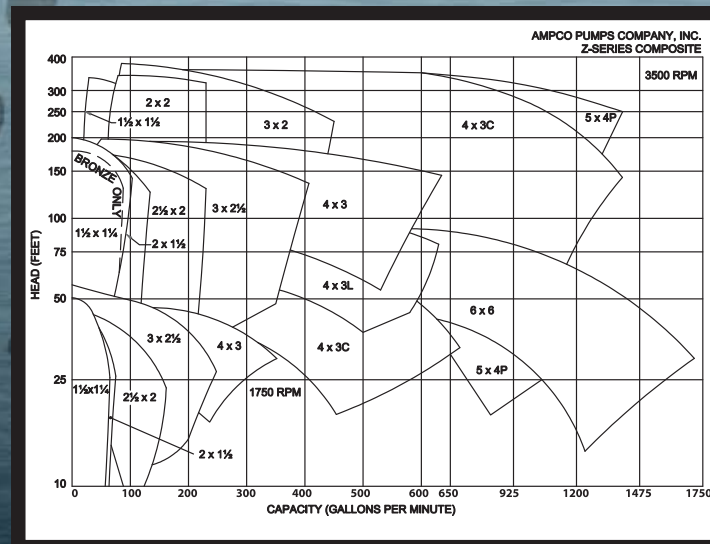

All assembled Ampco pumps are run on our test stand to verify hydraulic, mechanical and electrical performance prior to shipment.

Headquarters

2045 W. Mill Road
Glendale, WI 53209 / USA
Tel (414) 643-1852 • Fax (414) 643-4452
info@ampcopumps.com
www.ampcopumps.com

International Office

Steinstrasse 26
D-76889 Klingenstein / Germany
Tel +49 (6349) 963-403 • Fax +49 (6349) 963-404
info@ampcopumps.de
www.ampcopumps.de

Ampco Pumps Company

Marine and Industrial
CENTRIFUGAL PUMPS



K, R and Z Series pumps
are available from stock in
nickel aluminum bronze,
316 stainless steel and
duplex 2205 stainless steel

Marine & Industrial PUMPS

All K, R and Z Series pumps share the following characteristics:

- Heavy-wall cast construction with tight manufacturing tolerances
- High efficiency design with fully shrouded impellers
- Dynamically balanced impellers
- Close coupled on JM or 56J frame motors
- ABS (American Bureau of Shipping) type approval
- Every assembled unit is run on our test stand to verify hydraulic, mechanical and electrical performance

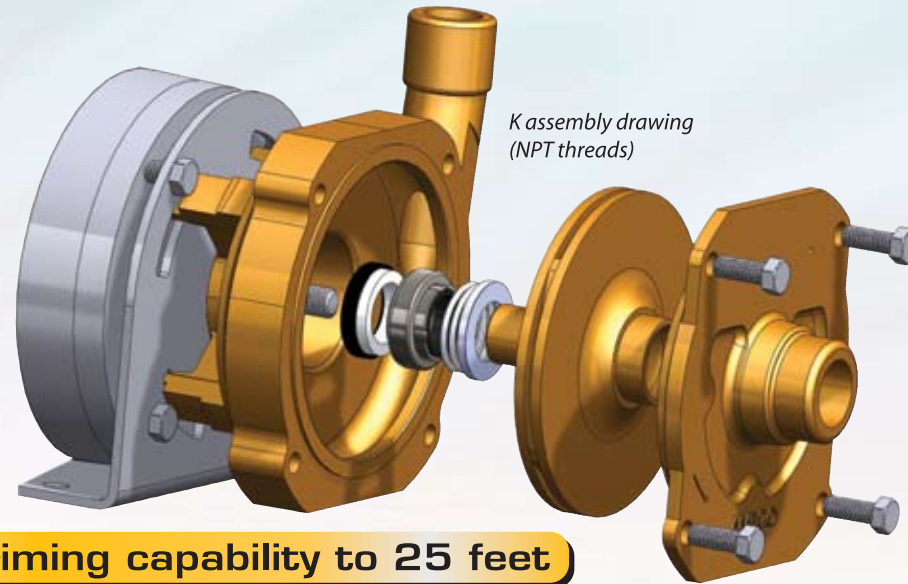

R Series pumps have self-priming capability to 25 feet

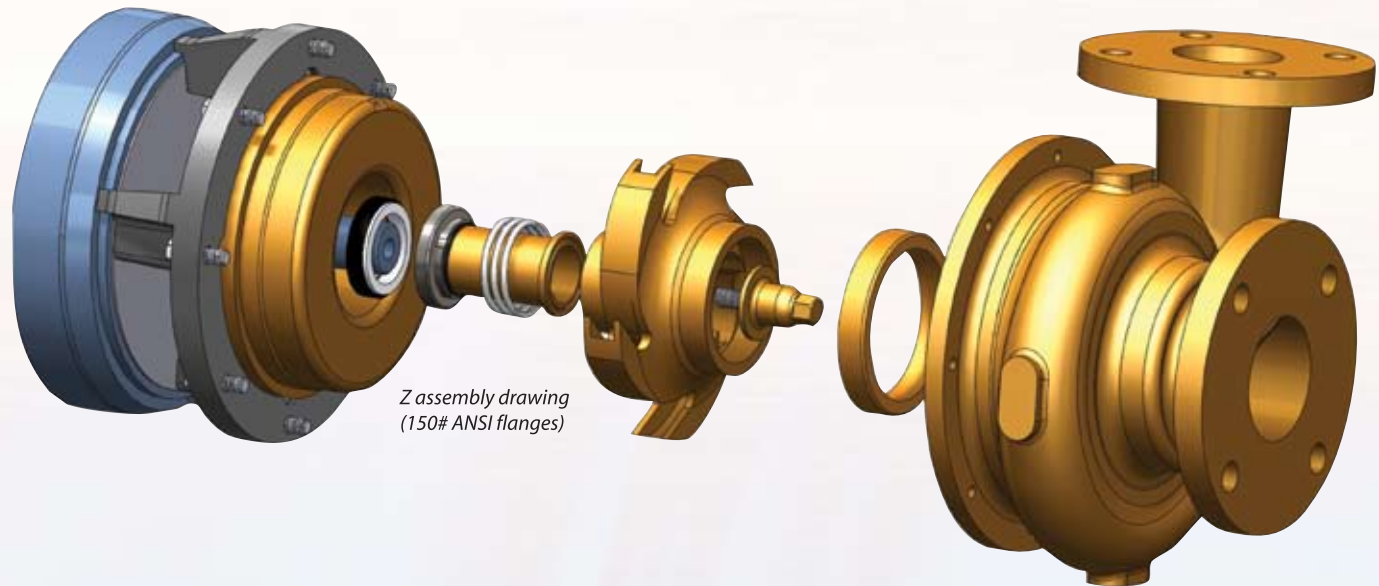

The standard mechanical seal for marine and industrial pumps is a Type 21 with ceramic versus carbon seal faces, buna elastomers and 316 SS metallics. Various material options are available, including silicon carbide, tungsten carbide, ni-resist, viton, EPDM, teflon, monel and others. Optional seal choices include Type 1, Type 9, double mechanical seals, packing and cartridge seals.

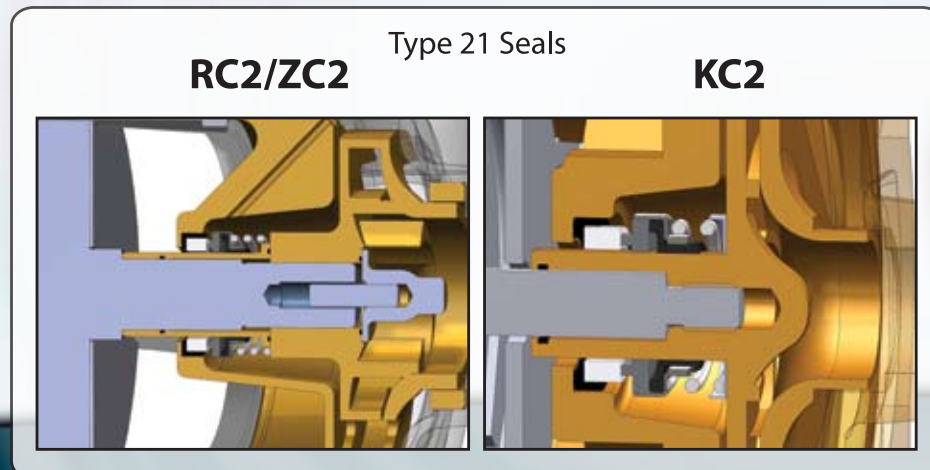

Alloy Selection

Ampco offers the K, R and Z Series pumps in nickel aluminum bronze (CDA958), 316 stainless steel and duplex 2205 stainless steel construction. All three alloys are in stock and normally available for delivery in one week or less. Our application engineers will help select the right alloy for your application.

Nickel aluminum bronze

- A very cost effective material for saltwater, as well as brackish water and waste water
- The overall corrosion / erosion resistance of this alloy to saltwater is far superior to stainless steel or standard bronzes
- The U.S. Navy has been using CDA958 in saltwater applications for over 40 years
- Ampco's K, R and Z Series pumps have been used on most of the U.S. Army's reverse osmosis systems since the 1980's

316 stainless steel:

- High resistance to corrosion from many chemical solutions
- The material of choice in food and beverage processing applications



Duplex 2205:

- Highly recommended for saltwater applications with higher salinity (over 30,000 ppm) and higher temperature
- Also recommended for saltwater applications with a high concentration of hydrogen sulfides (such as pumping from a deep seawater well) which will attack nickel aluminum bronze
- Superior resistance to the effects of cavitation
- Superior resistance to wear from abrasive media such as diatomaceous earth or ethanol



• Please see our website at www.ampcopumps.com for a complete compatibility chart for these alloys. We also manufacture K, R and Z Series pumps in specialty alloys such as Hastalloy C, Alloy 20, 316L stainless steel and others.